



UNIVERSITY OF CAMBRIDGE INTERNATIONAL EXAMINATIONS
International General Certificate of Secondary Education

PHYSICS

0625/52

Paper 5 Practical Test

May/June 2010

CONFIDENTIAL INSTRUCTIONS

Great care should be taken to ensure that any confidential information given does not reach the candidates either directly or indirectly.



If you have any problems or queries regarding these Instructions, please contact CIE
by e-mail: International@cie.org.uk,
by phone: +44 1223 553554,
by fax: +44 1223 553558,
stating the Centre number, the nature of the query and the syllabus number quoted above.

This document consists of **8** printed pages.



Instructions for preparing apparatus

The Supervisor is **not** allowed to consult the Question Paper before the examination. This should, as part of the preparation of the examination requirements, test the apparatus in order to ensure that it is satisfactory.

The Supervisor is asked to give (and attach to the Report form printed on pages 7 and 8) a *brief* description of the apparatus supplied, mentioning any points that are likely to be of importance to the Examiner in marking the answers. The Supervisor should also report any assistance given to candidates. All reports should be signed by the Supervisor and by the person responsible for preparing the apparatus.

In addition to the usual equipment of a physics laboratory, each candidate will require the apparatus specified in these Instructions. If a candidate breaks any of the apparatus, or loses any of the material supplied, the matter should be rectified and a note made in the Report.

Number of sets of apparatus

As a *minimum*, the number of sets of apparatus provided should be $N/4$, where N is the number of candidates (per session). A few spare sets should, preferably, be available to avoid any candidate being delayed when moving to another question.

Centres may find it more convenient and easier to administer if $N/3$ sets (plus one or two 'spares') of apparatus are provided.

The order in which a given candidate attempts the four questions is immaterial.

Assistance to Candidates

The purpose of the Practical Physics test is to find out whether the candidates can carry out simple practical work themselves. The Examiners are aware that candidates may sometimes be unable to show their practical ability through failure to understand some point in the theory of the experiment. If an Examiner were present in the laboratory, he/she would be willing to give a hint to enable such a candidate to get on with an experiment. In order to overcome this difficulty, the Supervisor is asked to co-operate with the Examiners to the extent of being ready to give (or allow the Physics teacher to give) a hint to a candidate who is unable to proceed.

The following regulations must be strictly adhered to.

- (i) No hint may be announced to the candidates as a whole.
- (ii) A candidate who is unable to proceed and requires assistance must come up to the Supervisor and state the difficulty. Candidates should be told that the Examiners will be informed of any assistance given in this way.
- (iii) A report must be made of any assistance given to the candidate, with the name and index number of the candidate.

It is suggested that the following announcement be made to the candidates.

'The Examiners do not want you to waste time through inability to get on with an experiment. Any candidate, therefore, who is unable to get on with the experiment after spending five minutes at it may come to me and ask for help. I shall report to the Examiners any help given in this way, and some marks may be lost for the help given. You may ask me for additional apparatus which you think would improve the accuracy of your experiments, and you should say, on your script, how you use any such apparatus supplied.'

Question 1**Items to be supplied by the Centre (per set of apparatus unless otherwise specified)**

- (i) Metre rule with a mm scale (see note 1 below).
- (ii) Triangular block to act as a pivot for the metre rule. This block is to stand on the bench.
- (iii) 30g mass (see note 2 below).
- (iv) A selection of masses so that candidates can use masses of 40g, 50g, 60g, 70g and 80g (eight 10g slotted masses would be suitable).

Notes

1. The metre rule should balance on the pivot when the 50 cm mark is approximately over the pivot.
2. The 30g mass is to be taped to the metre rule so that its centre is at the 90.0 cm mark. The value of the mass is not to be given or to be visible to the candidates.

Action at change over

Check that the 30g mass remains correctly taped to the metre rule.

Question 2

Items to be supplied by the Centre (per set of apparatus, unless otherwise specified)

- (i) Thermometer: -10°C to 110°C , graduated in 1°C intervals.
- (ii) 250cm^3 beaker, labelled **A**, with the 200cm^3 level clearly marked.
- (iii) A dish, labelled **B**, with low sides (e.g. a petri dish) that will hold sufficient water to cover the thermometer bulb as shown in Fig. 2.1.

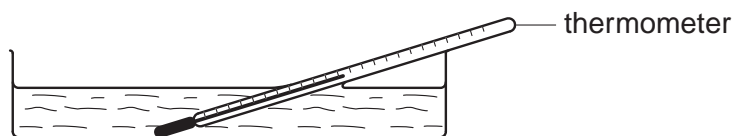

Fig. 2.1

- (iv) Boss, clamp and stand (this may be necessary to hold the thermometer so that the container does not tip over when the thermometer is put in).
- (v) Wall-mounted clock with a seconds sweep hand, stopclock or stopwatch. (Candidates will be required to take readings at 30s intervals. They may use their own wristwatch facility if they wish.)
- (vi) Supply of hot water.
- (vii) Supply of paper towels to mop up any spillages of water.

Notes

1. The hot water is to be supplied for each candidate by the Supervisor. The water temperature should be between 80°C and 100°C .
2. Candidates should be warned of the dangers of burns or scalds when using very hot water.
3. The candidates must be able easily and safely to move the thermometer in and out of the water without the danger of the containers tipping. (A means to support the thermometer may be required.)
4. The candidates must be provided with the means easily and safely to pour hot water into each of the two containers.

Action at changeover

Empty the beaker and dish. Check the supply of hot water.

Question 3**Items to be supplied by the Centre (per set of apparatus unless otherwise specified)**

- (i) Power source of approximately 1.5–2.0V. Where candidates are supplied with a power source with a variable output voltage, the voltage setting should be set by the Supervisor and fixed (e.g. taped).
- (ii) Voltmeter capable of measuring the supply p.d. with a minimum precision of 0.1 V.
- (iii) Ammeter capable of reading up to 1.0 A with a minimum precision of 0.05 A.
- (iv) Two 2.5V, 0.2 A lamps in suitable holders labelled **P** and **Q**.
- (v) Switch (this can be an integral part of the power supply).
- (vi) Sufficient connecting leads to set up a circuit using all the components listed with the lamps in parallel.

Notes

1. The circuit is to be set up for the candidates as shown in Fig. 3.1 with the additional leads and lamp **Q** within easy reach.
2. The candidates will rearrange the circuit so that the lamps are in parallel.

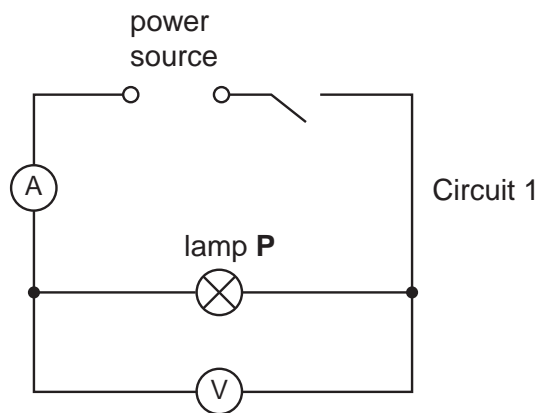
**Fig. 3.1****Action at changeover**

Reconnect the circuit as shown in Fig. 3.1.

Question 4**Items to be supplied by the Centre (per set of apparatus, unless otherwise specified)**

- (i) Sheet of plain A4 size paper with a hole in one corner so that it can be tied into the Question Paper (per candidate).
- (ii) Rectangular, transparent glass or Perspex block 10 cm × 6 cm × 1.5 cm or similar size.
- (iii) Four optics pins.
- (iv) Pin board (e.g. a cork mat) A4 size or larger.
- (v) Protractor.
- (vi) 50 cm or 30 cm rule, graduated in mm.
- (vii) String or treasury tag to tie sheet of paper ((i) above) into the Question Paper (per candidate).

Notes

1. Spare sheets of plain A4 size paper should be available.
2. Spare pins should be available.

Action at changeover

Supply sheet of plain A4 paper as in (i) above.

This form must be completed and returned with the scripts.

REPORT ON PRACTICAL PHYSICS

(IGCSE MAY/JUNE 2010)

General

The Supervisor is invited to give details of any difficulties experienced by particular candidates giving their names and candidate numbers. These should include reference to:

- (a) difficulties due to faulty apparatus;
- (b) accidents to apparatus or materials;
- (c) any other information that is likely to assist the Examiner, especially if this cannot be discovered in the scripts;
- (d) any help given to a candidate.

Information required

A plan of workbenches, giving details by candidate number of the places occupied by the candidates for each experiment for each session, must be enclosed with the scripts.

The space below can be used for this, or it may be on separate paper.



Information required (cont.)

A list by name and candidate number of candidates requiring help, with details of the help provided.

CENTRE NO.

NAME OF CENTRE

Declaration (to be signed by the Supervisor and the person responsible for preparing the apparatus)

The preparation of the practical examination has been carried out so as to maintain fully the security of the examination.

SIGNED
Supervisor

SIGNED
Person responsible for preparing the apparatus

