

Centre Number	Candidate Number	Name
---------------	------------------	------

UNIVERSITY OF CAMBRIDGE INTERNATIONAL EXAMINATIONS
International General Certificate of Secondary Education

COMBINED SCIENCE

0653/02

Paper 2 (Core)

October/November 2006

1 hour 15 minutes

Candidates answer on the Question Paper.
No Additional Materials are required.

READ THESE INSTRUCTIONS FIRST

Write your Centre number, candidate number and name on all the work you hand in.
Write in dark blue or black pen.
You may use a soft pencil for any diagrams, graphs, tables or rough working.
Do not use staples, paper clips, highlighters, glue or correction fluid.

Answer **all** questions.
A copy of the Periodic Table is printed on page 20.

At the end of the examination, fasten all your work securely together.
The number of marks is given in brackets [] at the end of each question or part question.

For Examiner's Use	
1	
2	
3	
4	
5	
6	
7	
8	
9	
10	
Total	

This document consists of **18** printed pages and **2** blank pages.

1 (a) The pie chart in Fig. 1.1 shows the energy sources used to generate the electricity in a European country in one year.

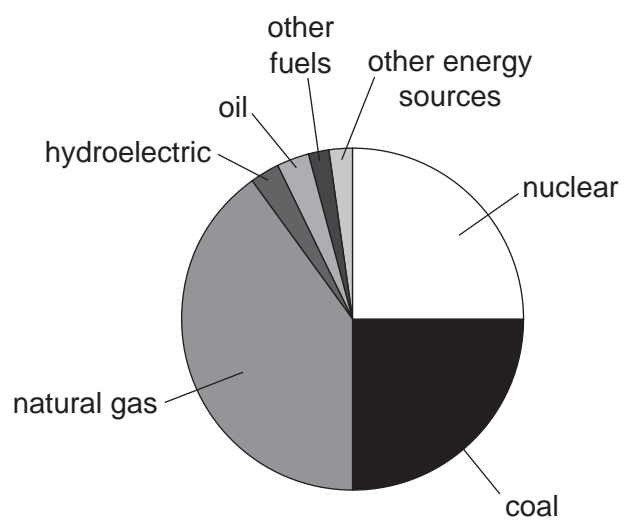

nuclear	25%
coal	25%
natural gas	40%
hydroelectric	3%
oil	3%
other fuels	2%
other energy sources	2%

Fig. 1.1

(i) Suggest **one** fuel which could have been included in the 'other fuels' section.

..... [1]

(ii) Calculate the percentage of the country's electricity that comes from fossil fuels listed in Fig. 1.1.

..... [1]

(iii) Hydroelectricity is a renewable energy resource. Name two other renewable energy resources.

1.

2.

[2]

(b) Generators are required in order to produce electricity in a power station. Complete the diagram below to show the processes involved.

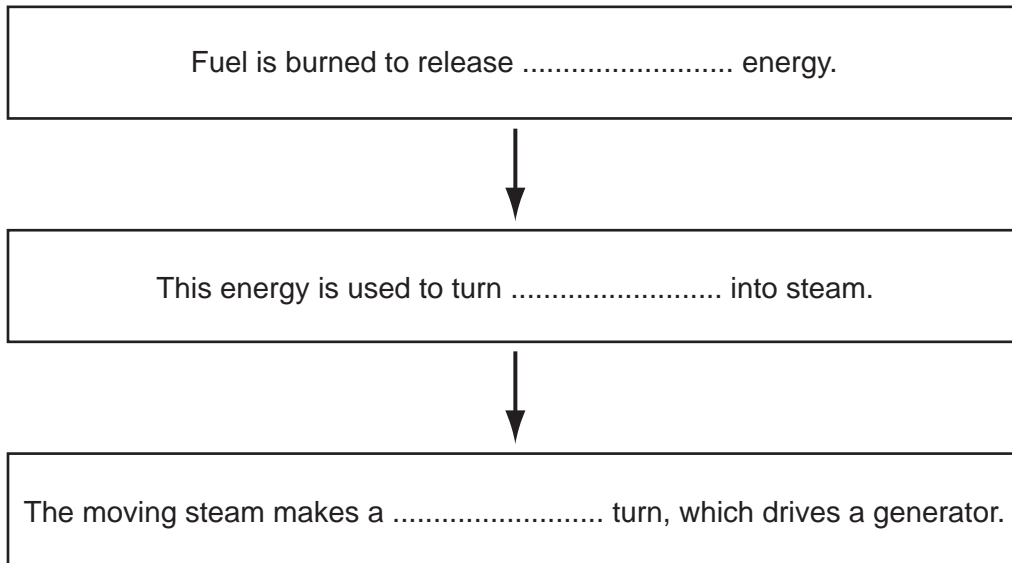

[3]

(c) Transformers are used to increase the voltage before electricity is transmitted.

Explain why this is done.

.....
.....

[1]

2 A student uses the apparatus shown in Fig. 2.1 to investigate several different chemical reactions. In each reaction, a solid reacts with hydrochloric acid and a gas is produced. The volume of gas produced in each case can be measured using the gas syringe.

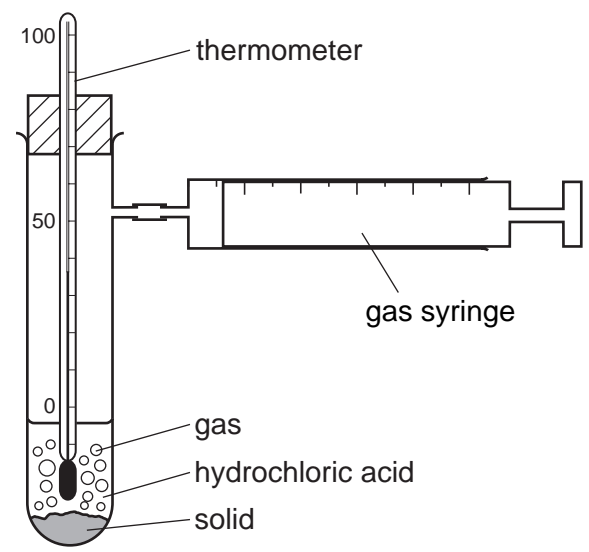

Fig. 2.1

(a) (i) Table 2.1 lists three experiments in which three different solids react with hydrochloric acid.

Complete Table 2.1 by writing in the right hand column the name of the gas produced.

Table 2.1

experiment number	solid reacted	gas produced
1	calcium carbonate	
2	magnesium	
3	sodium hydrogencarbonate	

[3]

(ii) Write the chemical formula of hydrochloric acid.

..... [1]

(iii) Choose **one** of the gases you have named in Table 2.1 and describe the test for this gas.

.....
.....
..... [2]

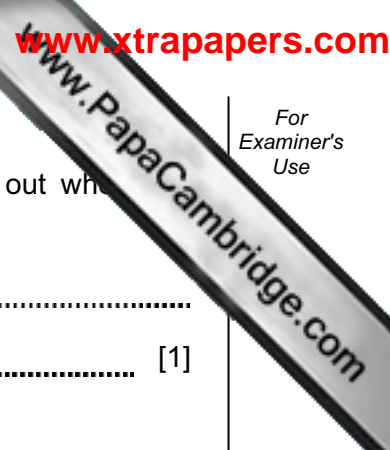

(b) How would the student use the apparatus shown in Fig. 2.1 to find out whether the reaction was exothermic?

.....
..... [1]

(c) The student finds that the rate of reaction is greatest for experiment 3.

(i) Suggest the measurements which the student took in order to find the rate of reaction in each experiment.

.....
.....
..... [2]

(ii) Suggest **one** way in which the student could change the conditions of experiment 3 in order to **reduce** the rate of reaction.

.....
..... [1]

3 Fig 3.1 shows a human fetus just before birth.

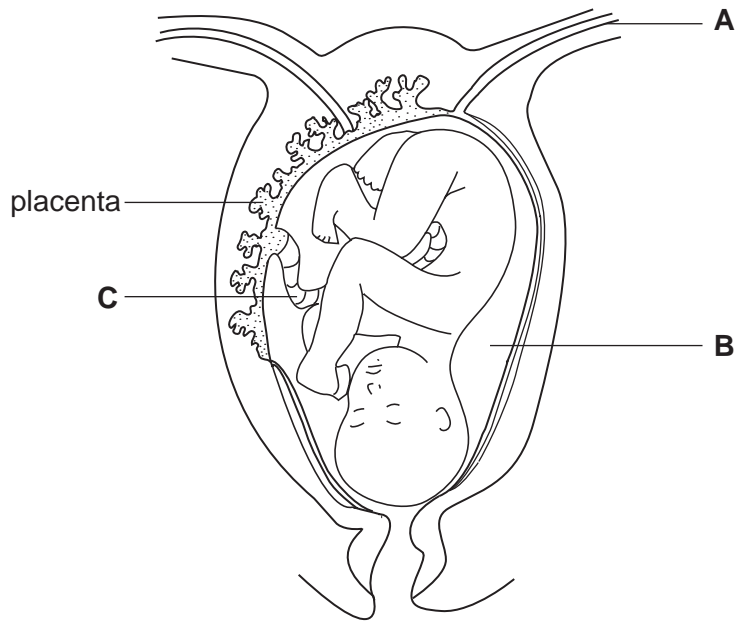

Fig. 3.1

(a) Name structures A to C, using some of these words.

amniotic fluid artery cervix oviduct umbilical cord zygote

A

B

C

[3]

(b) Explain how the developing fetus obtains nutrients while it is in the uterus.

.....

.....

.....

.....

[3]

(c) Outline what happens during the birth of the baby.

.....
.....
.....
..... [2]

(d) If a mother has AIDS, there is a risk that her baby may be born with HIV and develop AIDS.

Explain how this could happen.

.....
.....
..... [2]

4 (a) Fig. 4.1 shows a ray of light passing from air into a glass block.

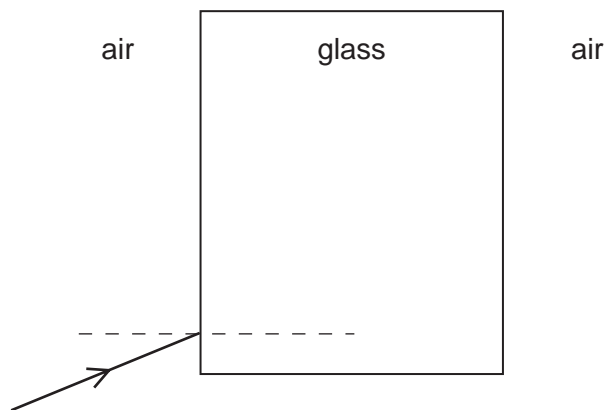
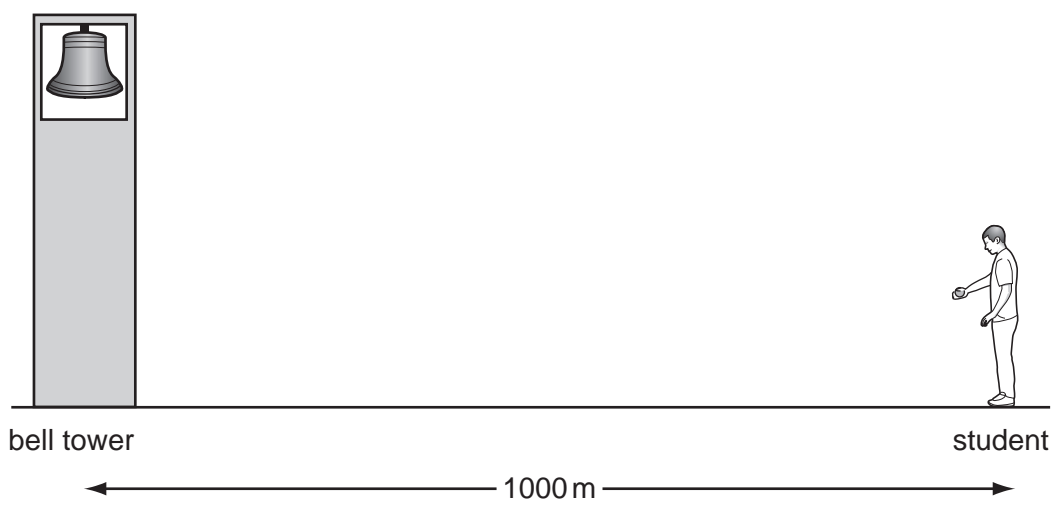

Fig. 4.1

- (i) On Fig. 4.1, draw two straight lines to show what happens to the ray of light as it passes through the block and out into the air. [2]
- (ii) On Fig. 4.1, indicate the angle of refraction as the ray enters the block. [1]

(b) A student carried out an experiment to find the speed of sound in air by watching and listening to a bell being rung. He stood with a timer 1000 m from the bell.



The sound took 3 seconds to travel from the bell to the student.

Calculate the speed of sound.

Show your working and state the formula that you use.

formula used

working

..... m/s [2]

5 Fig. 5.1 shows industrial apparatus used to obtain useful products, **A** to **F**, from petroleum (crude oil).

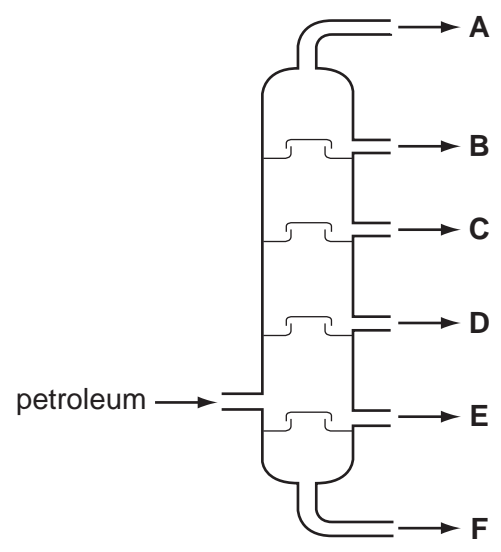

Fig. 5.1

(a) (i) Name the process shown in Fig. 5.1.

..... [1]

(ii) State which of the products, **A** to **F**, is at the highest temperature when it first comes out of the apparatus in Fig. 5.1.

..... [1]

(b) Product **B** in Fig. 5.1 is used as fuel for cars.

(i) Name the **element** which reacts with molecules of product **B** in car engines.

..... [1]

(ii) Describe and explain **one** way in which the use of product **B** as car fuel could be affecting our environment.

.....
.....
.....
..... [3]

(c) Plastics contain molecules called polymers.

Describe how a typical polymer molecule such as poly(ethene) is different from a simple molecule such as ethene.

.....

.....

..... [2]

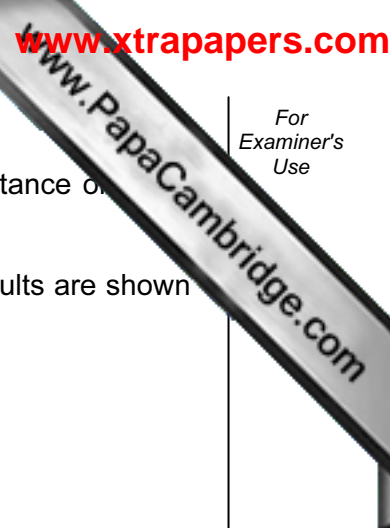

6 An athlete ran on a treadmill on three different days. He ran a different distance on each day.

The volume of oxygen that he used was measured during each run. The results are shown in Table 6.1.

Table 6.1

length of run / m	total oxygen used / dm ³
100	10
1500	36
10 000	150

(a) (i) Calculate the oxygen used per metre in the 100 metre run.

..... dm³ [1]

(ii) Describe the relationship shown in Table 6.1 between the oxygen used and the length of the run.

.....
..... [1]

(b) (i) Describe how the oxygen breathed in by the athlete was transported to his muscles.

.....
.....
..... [2]

(ii) Explain how the oxygen taken in by the athlete was used to provide the energy that he used in the runs.

.....
.....
.....
..... [3]

(c) Professional athletes never drink alcohol before a race. Suggest how drinking small amount of alcohol could increase an athlete's time in a 100 m race.

.....

.....

..... [2]

- 7 (a) A torch contains 3 cells, a switch and a lamp connected in series.
- (i) Draw a circuit diagram for this circuit using the correct symbols.

[3]

- (ii) The potential difference across each of the cells in the circuit is 1.5 V.
State the total potential difference across the three cells.

..... [1]

- (b) Visible light is one of the main regions of the electromagnetic spectrum.
Infra-red radiation is also a region of the electromagnetic spectrum.

- (i) State a source, a detector and a use of infra-red radiation.

source

.....

detector

.....

use

..... [3]

- (ii) Name **one** other region of the electromagnetic spectrum.

..... [1]

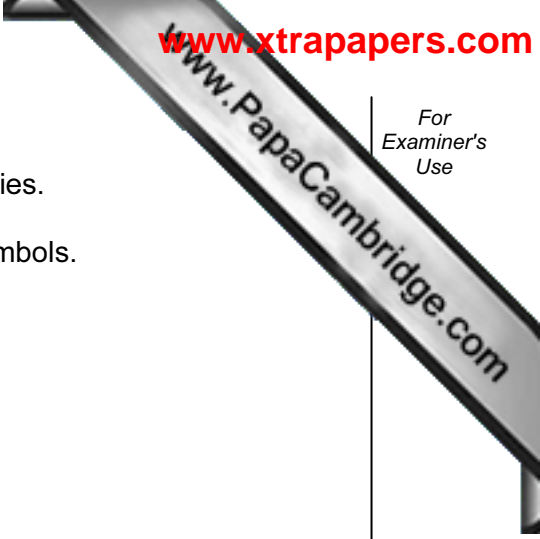

8 (a) Table 8.1 shows some properties of elements.

Write the letter **M** in the right hand column next to properties which are typical of **metallic** elements.

Table 8.1

can be hammered into different shapes	
poor conductor of heat	
is a gas at room temperature (20°C)	
good conductor of electricity	
poor conductor of electricity	

[2]

(b) Aluminium is an important metal in Group III of the Periodic Table.

(i) State the chemical symbol for aluminium.

..... [1]

(ii) State the number of protons in one atom of aluminium.

..... [1]

(iii) Why is aluminium a suitable material for making containers used to store food?

.....
..... [1]

(c) Aluminium is obtained from the compound aluminium oxide.

Explain why aluminium oxide is called a compound and not an element.

.....
.....
..... [2]

(d) Electrolysis is used to extract aluminium from aluminium oxide, an ionic compound which is insoluble in water.

(i) How can aluminium oxide be made into an electrolyte?

..... [1]

(ii) Complete the word equation below to show the chemical change that occurs when aluminium oxide undergoes electrolysis.

..... → aluminium + [1]

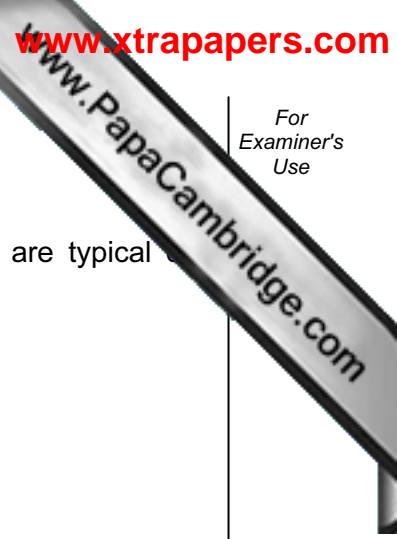

9 Fig. 9.1 shows a root hair cell.

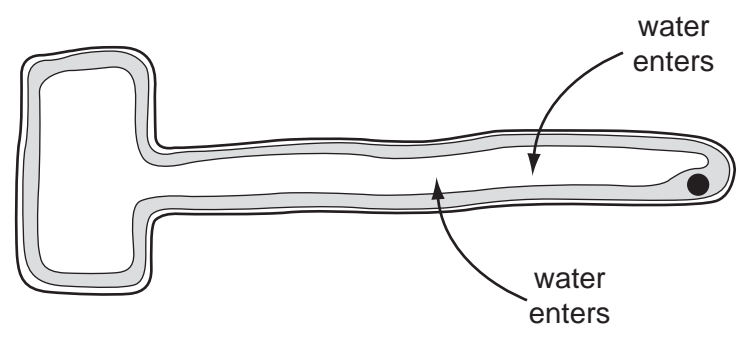

Fig. 9.1

(a) State two ways in which the structure of this cell differs from a palisade cell in a leaf.

1.
.....
 2.
.....
- [2]

(b) The function of a root hair is to take up water from the soil. The arrows in Fig. 9.1 show water entering the root hair cell.

(i) How many membranes does the water pass through between the soil and the vacuole of the root hair cell?

..... [1]

(ii) Describe the pathway taken by the water as it travels from the root hair and into the leaves of the plant.

.....
.....
.....

[2]

(iii) Some of the water is used in photosynthesis in the leaves of the plant. Write the word equation for photosynthesis.

..... [2]

(iv) On a hot, sunny day much more water goes into the root hair cell than on a cold, dull day. Suggest an explanation for this.

.....
.....
.....

[1]

10 (a) Explain why it could be dangerous to switch on a mains electrical appliance using wet hands.

.....
.....
..... [2]

(b) Explain why a source of alpha radiation is more dangerous if it gets inside the human body than outside the body.

.....
.....
..... [2]

(c) Explain why small expansion gaps are left between sections of road bridges.

.....
.....
..... [1]

Permission to reproduce items where third-party owned material protected by copyright is included has been sought and cleared where possible. Every reasonable effort has been made by the publisher (UCLES) to trace copyright holders, but if any items requiring clearance have unwittingly been included, the publisher will be pleased to make amends at the earliest possible opportunity.

University of Cambridge International Examinations is part of the Cambridge Assessment Group. Cambridge Assessment is the brand name of University of Cambridge Local Examinations Syndicate (UCLES), which is itself a department of the University of Cambridge.

DATA SHEET
The Periodic Table of the Elements

		Group																																																																		
I	II	III	IV	V	VI	VII	0																																																													
7 Li Lithium 3	9 Be Beryllium 4	1 H Hydrogen 1	11 B Boron 5	12 C Carbon 6	14 N Nitrogen 7	16 O Oxygen 8	19 F Fluorine 9	20 Ne Neon 10	23 Na Sodium 11	24 Mg Magnesium 12	27 Al Aluminium 13	28 Si Silicon 14	31 P Phosphorus 15	32 S Sulphur 16	35.5 Cl Chlorine 17	40 Ar Argon 18	39 K Potassium 19	40 Ca Calcium 20	45 Sc Scandium 21	48 Ti Titanium 22	51 V Vanadium 23	52 Cr Chromium 24	55 Mn Manganese 25	56 Fe Iron 26	59 Co Cobalt 27	59 Ni Nickel 28	64 Cu Copper 29	65 Zn Zinc 30	70 Ga Gallium 31	73 Ge Germanium 32	75 As Arsenic 33	79 Se Selenium 34	80 Br Bromine 35	84 Kr Krypton 36	85 Rb Rubidium 37	88 Sr Strontium 38	89 Y Yttrium 39	91 Zr Zirconium 40	93 Nb Niobium 41	96 Mo Molybdenum 42	101 Ru Ruthenium 44	106 Pd Palladium 46	108 Ag Silver 47	112 Cd Cadmium 48	115 In Indium 49	119 Sn Tin 50	122 Sb Antimony 51	127 I Iodine 53	131 Xe Xenon 54	133 Cs Caesium 55	137 Ba Barium 56	139 La Lanthanum 57	178 Hf Hafnium 72	181 Ta Tantalum 73	184 W Tungsten 74	186 Re Rhenium 75	190 Os Osmium 76	195 Pt Platinum 78	197 Au Gold 79	201 Hg Mercury 80	204 Tl Thallium 81	207 Pb Lead 82	209 Bi Bismuth 83	210 Po Polonium 84	210 At Astatine 85	226 Ra Radium 88	227 Ac Actinium 89	227 Fr Francium 87

* 58-71 Lanthanoid series
† 90-103 Actinoid series

a	X	a = relative atomic mass
b	X	X = atomic symbol
Key	X	b = proton (atomic) number

140 Ce Cerium 58	141 Pr Praseodymium 59	144 Nd Neodymium 60	150 Sm Samarium 62	152 Eu Europium 63	157 Gd Gadolinium 64	159 Tb Terbium 65	162 Dy Dysprosium 66	165 Ho Holmium 67	167 Er Erbium 68	169 Tm Thulium 69	173 Yb Ytterbium 70	175 Lu Lutetium 71	
232 Th Thorium 90	232 Pa Protactinium 91	238 U Uranium 92	238 Np Neptunium 93	238 Pu Plutonium 94	238 Am Americium 95	238 Cm Curium 96	238 Bk Berkelium 97	238 Cf Californium 98	238 Es Einsteinium 99	238 Fm Fermium 100	238 Md Mendelevium 101	238 No Nobelium 102	238 Lr Lawrencium 103

The volume of one mole of any gas is 24 dm³ at room temperature and pressure (r.t.p.).