



Cambridge IGCSE™

CO-ORDINATED SCIENCES**0654/12**

Paper 1 Multiple Choice (Core)

October/November 2021**45 minutes**

You must answer on the multiple choice answer sheet.

You will need: Multiple choice answer sheet
Soft clean eraser
Soft pencil (type B or HB is recommended)

INSTRUCTIONS

- There are **forty** questions on this paper. Answer **all** questions.
- For each question there are four possible answers **A, B, C** and **D**. Choose the **one** you consider correct and record your choice in soft pencil on the multiple choice answer sheet.
- Follow the instructions on the multiple choice answer sheet.
- Write in soft pencil.
- Write your name, centre number and candidate number on the multiple choice answer sheet in the spaces provided unless this has been done for you.
- Do **not** use correction fluid.
- Do **not** write on any bar codes.
- You may use a calculator.

INFORMATION

- The total mark for this paper is 40.
- Each correct answer will score one mark.
- Any rough working should be done on this question paper.
- The Periodic Table is printed in the question paper.

This document has **20** pages. Any blank pages are indicated.



2

1 All living organisms can break down nutrient molecules to release energy.

What is this process?

- A excretion
- B growth
- C nutrition
- D respiration

2 The diagram shows a plant cell as seen under a light microscope.

Which structure is also found in animal cells?

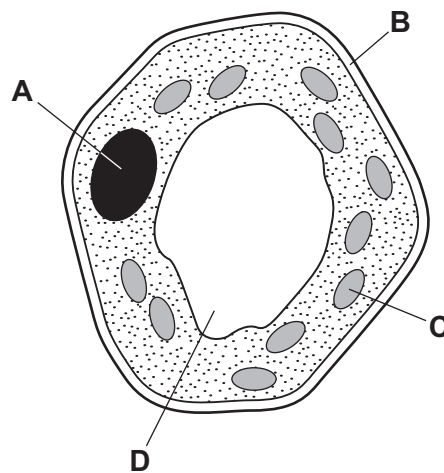

3 Which molecule contains carbon?

- A ammonia
- B fat
- C sulfuric acid
- D water

3

- 4 A student carried out an investigation on the effect of temperature on an enzyme-controlled reaction. The results are shown.

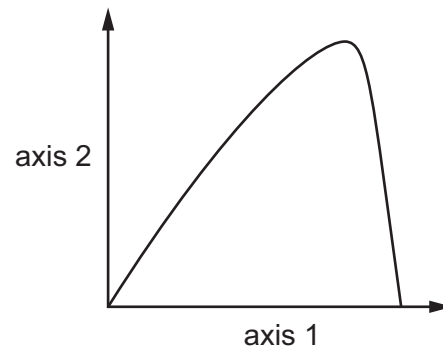

Which labels does the student need to add for the axes labelled axis 1 and axis 2?

	axis 1	axis 2
A	rate of reaction	temperature
B	rate of reaction	time
C	temperature	rate of reaction
D	time	rate of reaction

- 5 The diagram shows an experiment to investigate photosynthesis. When leaves photosynthesise, they store some carbohydrates as starch.

Potassium hydroxide absorbs carbon dioxide.

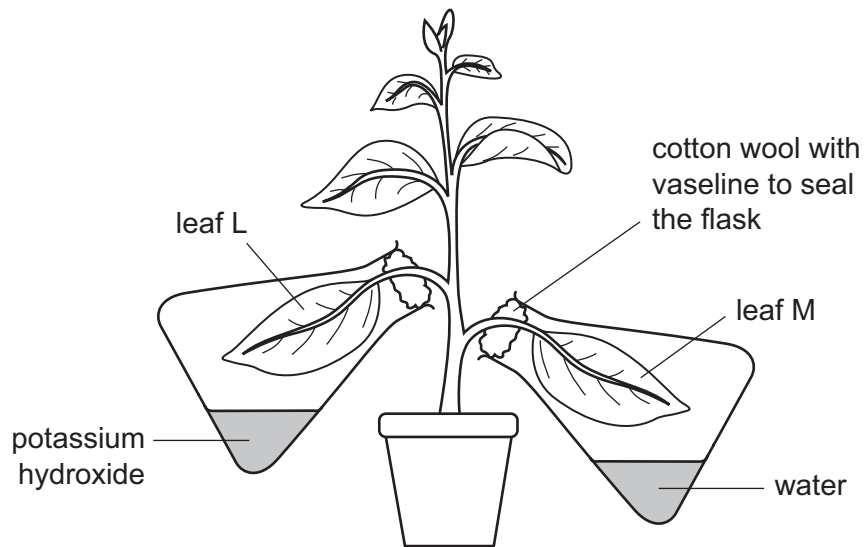

After standing in sunlight for 10 hours, leaf L contained no starch but leaf M contained a lot of starch.

What does this show?

- A A leaf cannot make starch in a sealed flask.
 - B A leaf cannot make starch without carbon dioxide.
 - C A leaf cannot make starch without light.
 - D A leaf cannot make starch without oxygen.
- 6 What is the name of the process which moves soluble food molecules through the wall of the small intestine into the blood?
- A absorption
 - B assimilation
 - C digestion
 - D ingestion

7 The diagram shows a section through a mammalian heart.

Which vessel is the pulmonary vein?

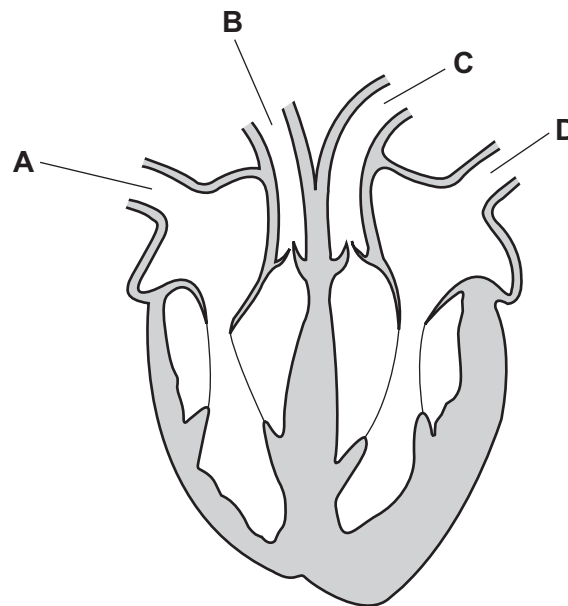

8 The graph shows the changes in volume of air in the lungs at rest and during exercise.

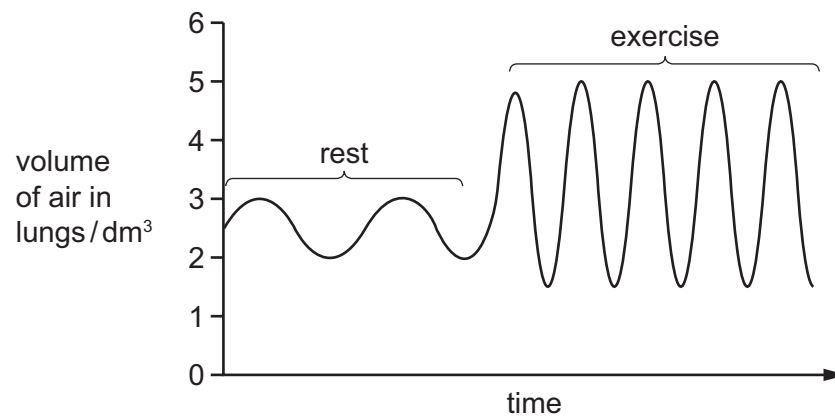

What was the effect of exercise on the rate and depth of breathing?

	rate of breathing	depth of breathing
A	decrease	decrease
B	decrease	increase
C	increase	decrease
D	increase	increase

- 9 Adrenaline is injected into the blood to treat some medical conditions.

What would happen as a result of injecting adrenaline?

- 1 narrowing of the pupil in the eye
- 2 increased breathing rate
- 3 increased pulse rate

A 1 and 2 only **B** 1 and 3 only **C** 2 and 3 only **D** 1, 2 and 3

- 10 The diagram shows the female reproductive system.

Which labelled part is the cervix?

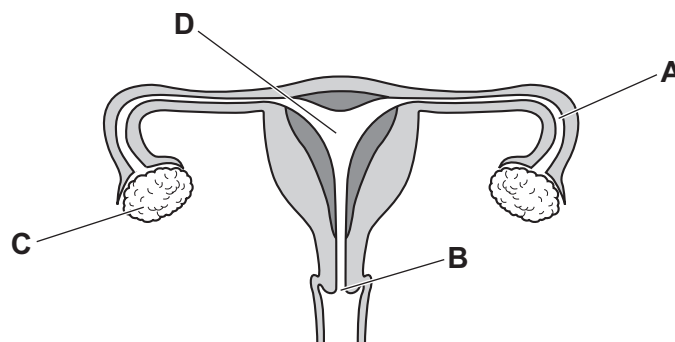

- 11 In a species of flowering plant, the allele for red flowers is dominant to the allele for white flowers.

A plant breeder crossed a homozygous white-flowered plant with a heterozygous red-flowered plant.

What is the expected phenotypic ratio of the next generation of plants?

- A** 1 white : 1 red
- B** 3 red : 1 white
- C** 3 white : 1 red
- D** all the plants will be red

- 12 Which organism is a secondary consumer in the food chain shown?

A **B** **C** **D**
 plant → herbivore → carnivore → top carnivore

13 The diagram shows a simplified carbon cycle.

Which labelled arrow represents respiration?

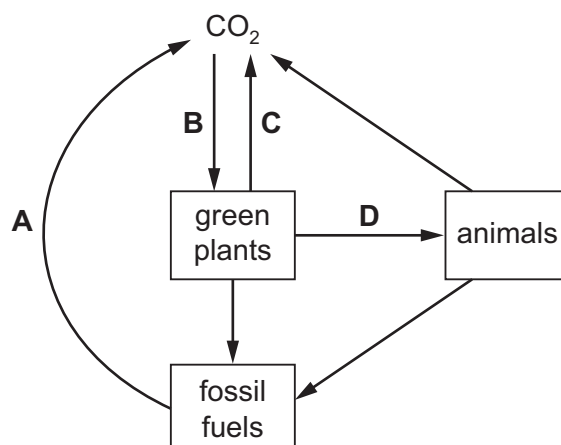

14 Which row correctly identifies the named changes?

	physical changes	chemical changes
A	condensation and combustion	evaporation and neutralisation
B	evaporation and neutralisation	condensation and combustion
C	condensation and evaporation	combustion and neutralisation
D	combustion and neutralisation	condensation and evaporation

15 Which row describes the physical properties of the named substances?

	substance	solubility in water	electrical conductivity as a solid	electrical conductivity as a liquid
A	ammonia	low	good	good
B	copper chloride	high	poor	good
C	iron nitrate	high	good	good
D	potassium chloride	low	poor	poor

16 A model of a molecule is shown.

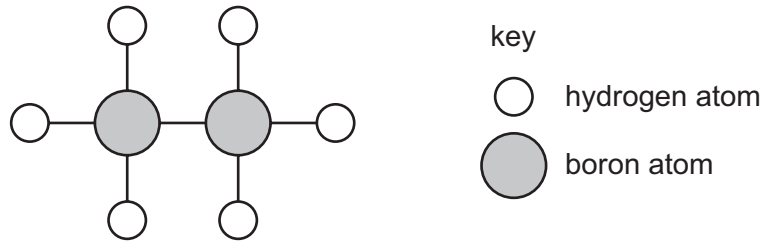

Which row shows the formula of this molecule and describes the type of bonding between the atoms?

	formula	bonding
A	2BH_3	covalent
B	2BH_3	ionic
C	B_2H_6	covalent
D	B_2H_6	ionic

17 The diagram shows the electrolysis of a compound.

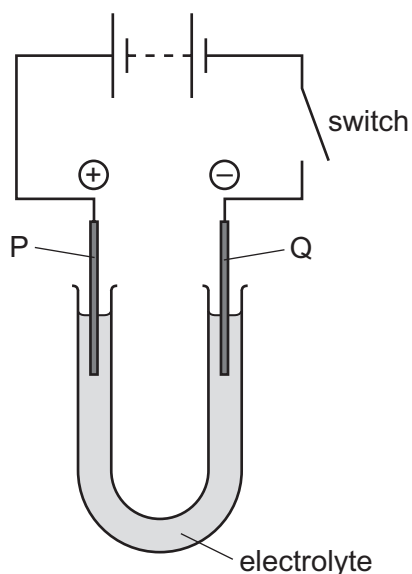

When the switch is closed, the solution around electrode P turns orange because a halogen is formed.

The positive electrode P is called the1....., and the halogen is2..... .

Which words complete gaps 1 and 2?

	1	2
A	anode	bromine
B	anode	chlorine
C	cathode	bromine
D	cathode	chlorine

18 Magnesium ribbon is added to dilute hydrochloric acid.

Which observation shows that this process is exothermic?

- A** The pH of the solution decreases.
- B** The pH of the solution increases.
- C** The temperature of the solution decreases.
- D** The temperature of the solution increases.

19 A known mass of solid sodium carbonate is added to excess hydrochloric acid.

Which conditions give the shortest reaction time?

	solid particle size	acid concentration
A	large	high
B	large	low
C	small	high
D	small	low

20 A white solid X dissolves in dilute hydrochloric acid. A gas is produced which turns limewater milky.

A flame test is carried out on solid X and produces a red coloured flame.

What is X?

- A** lithium carbonate
- B** lithium chloride
- C** potassium carbonate
- D** potassium chloride

21 Some properties of different metals are shown.

	$\frac{\text{density}}{\text{g/cm}^3}$	melting point/ $^{\circ}\text{C}$	colour of compound formed by the metal
1	1.54	851	white
2	8.91	1455	green
3	5.80	1890	lilac
4	11.3	328	white

Which metals are transition elements?

- A** 1 and 2 **B** 1 and 4 **C** 2 and 3 **D** 3 and 4

22 Why does the steel used to make a drill contain manganese?

- A** to increase the density of the steel
- B** to increase the hardness of the steel
- C** to increase the malleability of the steel
- D** to increase the melting point of the steel

23 Which colour is observed when water is added to anhydrous copper(II) sulfate?

- A blue
- B green
- C pink
- D white

24 Which process does **not** produce carbon dioxide?

- A complete combustion of fossil fuels
- B reaction of an acid with a carbonate
- C respiration in plants
- D rusting iron

25 Which compound is used to neutralise acidic gases?

- A calcium carbonate
- B calcium chloride
- C calcium phosphate
- D calcium sulfate

26 Four molecules are shown.

Which structure represents ethanol?

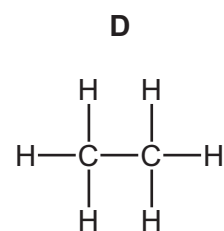
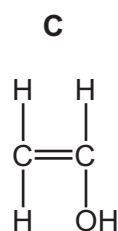
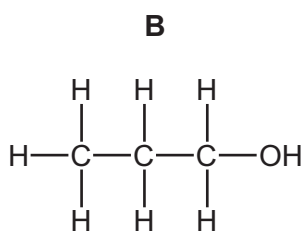
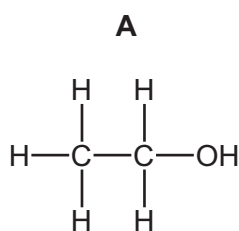

27 Which process produces alkenes from alkanes?

- A combustion
- B cracking
- C oxidation
- D reduction

28 Which speed–time graph represents the motion of an object in free fall with **no** air resistance?

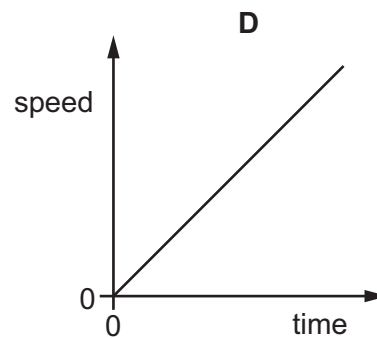
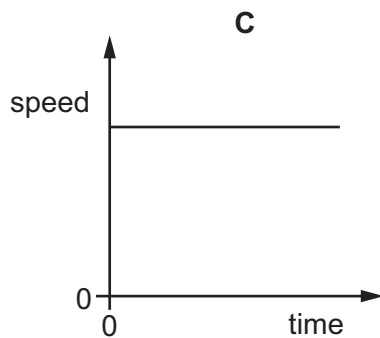
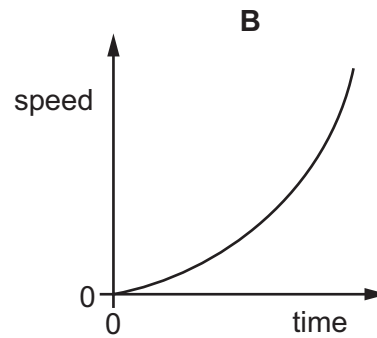
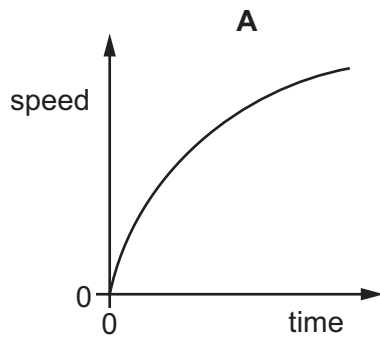

29 What is meant by the *moment* of a force?

- A** the speed of an object moved by a force
- B** the time taken for a force to move an object
- C** the turning effect of a force
- D** the work done by a force

30 A stone falls from a bench.

Which row describes how the gravitational potential energy and the kinetic energy of the stone change as it falls?

	gravitational potential energy	kinetic energy
A	decreases	increases
B	decreases	stays the same
C	increases	decreases
D	increases	stays the same

- 31 Four different kettles contain different masses of water.
They are used to heat the water from 20 °C to 100 °C.
Each kettle takes a different amount of time to do this.
Which kettle has the lowest useful power output?

	mass of water / g	time to heat water to 100 °C / minute
A	1000	3.0
B	1000	5.0
C	2500	3.0
D	2500	5.0

- 32 Which labelled arrow on the diagram represents condensation?

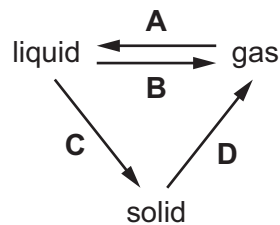

- 33 The diagram shows a ray of light striking a plane mirror.

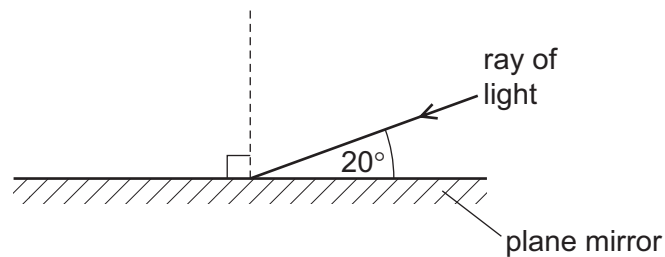

What is the angle of reflection?

- A** 20° **B** 40° **C** 70° **D** 90°

34 The diagrams P, Q, R and S show four pairs of bar magnets.

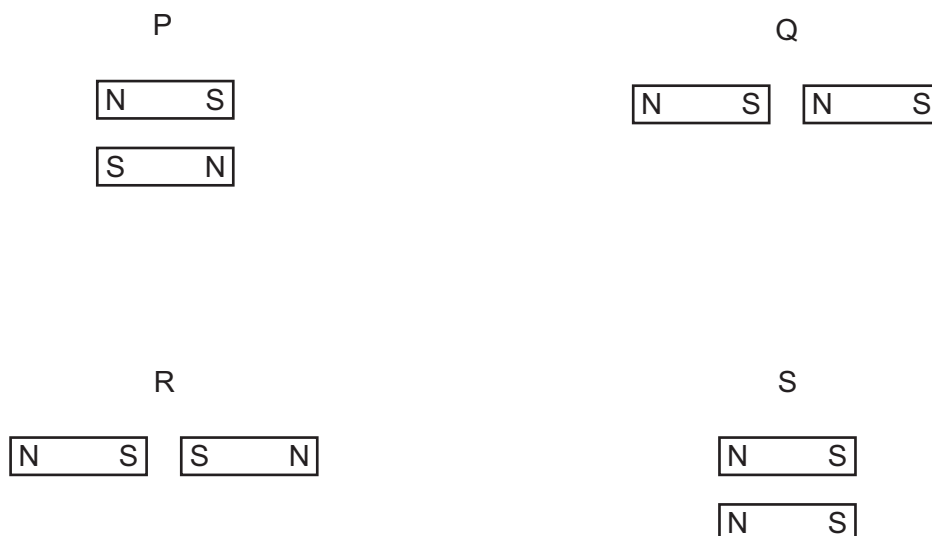

For which two pairs of magnets is there a force of attraction between the magnets?

- A** P and Q **B** Q and R **C** R and S **D** P and S

35 A rod is rubbed with a dry piece of cloth. A scientist holds the rod in her hand and brings it close to a negatively charged plastic strip. The strip is suspended by an insulating thread.

As the rod approaches the plastic strip, the strip moves towards the rod.

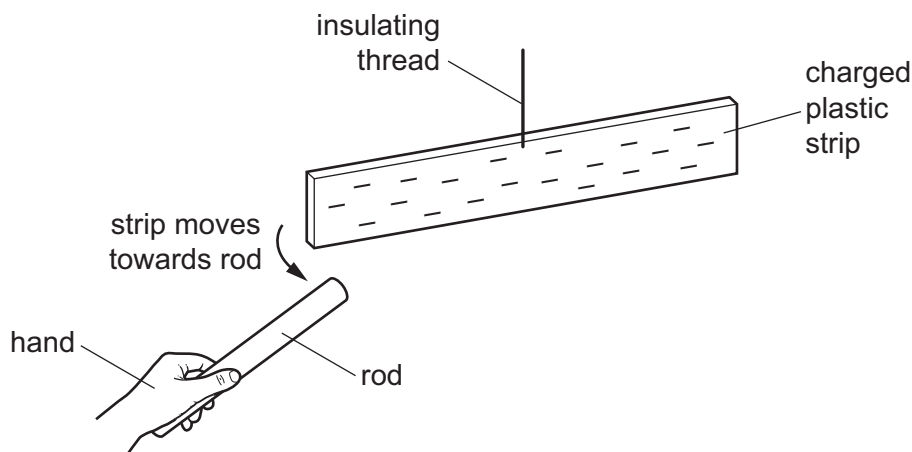

Which statement is correct?

- A** The rod is a negatively charged electrical conductor.
B The rod is a negatively charged electrical insulator.
C The rod is a positively charged electrical conductor.
D The rod is a positively charged electrical insulator.

36 Two lamps are connected in the circuit shown.

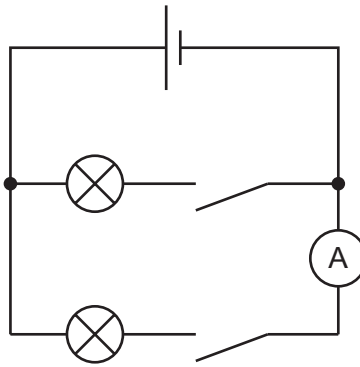

Which of these two statements about the circuit are correct?

- 1 There is a separate switch to control each lamp.
- 2 The ammeter measures the current in both lamps.

- A** neither 1 nor 2
B 1 only
C 2 only
D 1 and 2

37 Three resistors are connected in series with a battery, as shown.

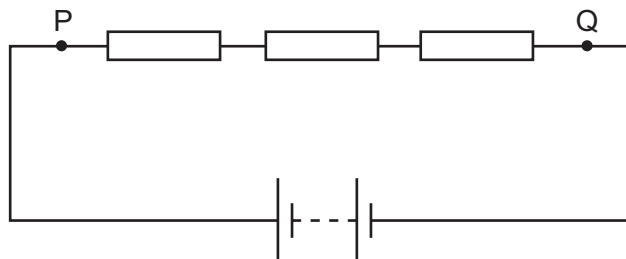

The current at point P is 6.0 A.

What is the current at point Q?

- A** 0 A **B** 2.0 A **C** 3.0 A **D** 6.0 A

- 38 An electric kettle, washing machine and cooker are all switched on and connected through an extension cable into a single mains socket.

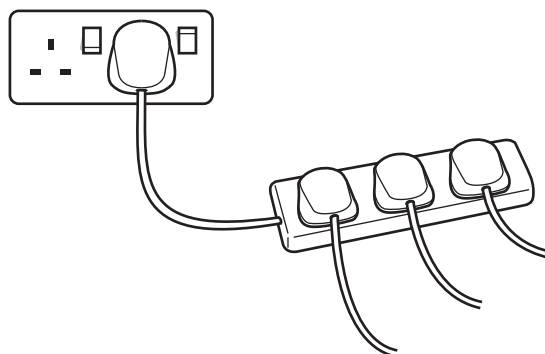

What is the electrical hazard of this arrangement?

- A The cooker overheats.
 B The extension cable overheats.
 C The kettle overheats.
 D The washing machine overheats.
- 39 There is a current in a coil of wire. The coil rotates between the poles of a magnet.

Which change does **not** increase the turning effect on the coil?

- A increasing the current in the coil
 B reversing the current
 C using a stronger magnet
 D using more turns in the coil
- 40 The table gives information about four nuclides P, Q, R and S.

nuclide	number of protons	number of neutrons
P	81	123
Q	82	122
R	82	123
S	83	121

Which nuclides are isotopes of the same element?

- A P and Q B P and R C Q and R D Q and S

BLANK PAGE

BLANK PAGE

BLANK PAGE

Permission to reproduce items where third-party owned material protected by copyright is included has been sought and cleared where possible. Every reasonable effort has been made by the publisher (UCLES) to trace copyright holders, but if any items requiring clearance have unwittingly been included, the publisher will be pleased to make amends at the earliest possible opportunity.

To avoid the issue of disclosure of answer-related information to candidates, all copyright acknowledgements are reproduced online in the Cambridge Assessment International Education Copyright Acknowledgements Booklet. This is produced for each series of examinations and is freely available to download at www.cambridgeinternational.org after the live examination series.

Cambridge Assessment International Education is part of the Cambridge Assessment Group. Cambridge Assessment is the brand name of the University of Cambridge Local Examinations Syndicate (UCLES), which itself is a department of the University of Cambridge.

The Periodic Table of Elements

Group																	
I	II	III										IV	V	VI	VII	VIII	
3 Li lithium 7	4 Be beryllium 9	<div style="border: 1px solid black; padding: 5px; text-align: center;"> Key atomic number atomic symbol name relative atomic mass </div>										5 B boron 11	6 C carbon 12	7 N nitrogen 14	8 O oxygen 16	9 F fluorine 19	10 Ne neon 20
11 Na sodium 23	12 Mg magnesium 24											13 Al aluminium 27	14 Si silicon 28	15 P phosphorus 31	16 S sulfur 32	17 Cl chlorine 35.5	18 Ar argon 40
19 K potassium 39	20 Ca calcium 40	21 Sc scandium 45	22 Ti titanium 48	23 V vanadium 51	24 Cr chromium 52	25 Mn manganese 55	26 Fe iron 56	27 Co cobalt 59	28 Ni nickel 59	29 Cu copper 64	30 Zn zinc 65	31 Ga gallium 70	32 Ge germanium 73	33 As arsenic 75	34 Se selenium 79	35 Br bromine 80	36 Kr krypton 84
37 Rb rubidium 85	38 Sr strontium 88	39 Y yttrium 89	40 Zr zirconium 91	41 Nb niobium 93	42 Mo molybdenum 96	43 Tc technetium —	44 Ru ruthenium 101	45 Rh rhodium 103	46 Pd palladium 106	47 Ag silver 108	48 Cd cadmium 112	49 In indium 115	50 Sn tin 119	51 Sb antimony 122	52 Te tellurium 128	53 I iodine 127	54 Xe xenon 131
55 Cs caesium 133	56 Ba barium 137	57–71 lanthanoids	72 Hf hafnium 178	73 Ta tantalum 181	74 W tungsten 184	75 Re rhenium 186	76 Os osmium 190	77 Ir iridium 192	78 Pt platinum 195	79 Au gold 197	80 Hg mercury 201	81 Tl thallium 204	82 Pb lead 207	83 Bi bismuth 209	84 Po polonium —	85 At astatine —	86 Rn radon —
87 Fr francium —	88 Ra radium —	89–103 actinoids	104 Rf rutherfordium —	105 Db dubnium —	106 Sg seaborgium —	107 Bh bohrium —	108 Hs hassium —	109 Mt meitnerium —	110 Ds darmstadtium —	111 Rg roentgenium —	112 Cn copernicium —	114 Fl flerovium —	116 Lv livermorium —	—	—	—	—

lanthanoids	57 La lanthanum 139	58 Ce cerium 140	59 Pr praseodymium 141	60 Nd neodymium 144	61 Pm promethium —	62 Sm samarium 150	63 Eu europium 152	64 Gd gadolinium 157	65 Tb terbium 159	66 Dy dysprosium 163	67 Ho holmium 165	68 Er erbium 167	69 Tm thulium 169	70 Yb ytterbium 173	71 Lu lutetium 175
actinoids	89 Ac actinium —	90 Th thorium 232	91 Pa protactinium 231	92 U uranium 238	93 Np neptunium —	94 Pu plutonium —	95 Am americium —	96 Cm curium —	97 Bk berkelium —	98 Cf californium —	99 Es einsteinium —	100 Fm fermium —	101 Md mendelevium —	102 No nobelium —	103 Lr lawrencium —

The volume of one mole of any gas is 24 dm³ at room temperature and pressure (r.t.p.).