



Cambridge IGCSE™

CO-ORDINATED SCIENCES**0654/52**

Paper 5 Practical Test

May/June 2022

CONFIDENTIAL INSTRUCTIONS

This document gives details of how to prepare for and administer the practical exam.

The information in this document and the identity of any materials supplied by Cambridge International are confidential and must NOT reach candidates either directly or indirectly.

The supervisor must complete the report at the end of this document and return it with the scripts.

INSTRUCTIONS

- If you have any queries regarding these confidential instructions, contact Cambridge International stating the centre number, the syllabus and component number and the nature of the query.
email info@cambridgeinternational.org
phone +44 1223 553554

This document has **8** pages. Any blank pages are indicated.

General information about practical exams

Centres must follow the guidance on science practical exams given in the *Cambridge Handbook*.

Safety

Supervisors must follow national and local regulations relating to safety and first aid.

Only those procedures described in the question paper should be attempted.

Supervisors must inform candidates that materials and apparatus used in the exam should be treated with caution. Suitable eye protection should be used where necessary.

The following hazard codes are used in these confidential instructions, where relevant:

C	corrosive	MH	moderate hazard
HH	health hazard	T	acutely toxic
F	flammable	O	oxidising
N	hazardous to the aquatic environment		

Hazard data sheets relating to substances used in this exam should be available from your chemical supplier.

Before the exam

- The packets containing the question papers must **not** be opened before the exam.
- It is assumed that standard school laboratory facilities, as indicated in the *Guide to Planning Practical Science*, will be available.
- Spare materials and apparatus for the tasks set must be available for candidates, if required.

During the exam

- It must be made clear to candidates at the start of the exam that they may request spare materials and apparatus for the tasks set.
- Where specified, the supervisor **must** perform the experiments and record the results as instructed. This must be done **out of sight** of the candidates, using the same materials and apparatus as the candidates.
- Any assistance provided to candidates must be recorded in the supervisor's report.
- If any materials or apparatus need to be replaced, for example, in the event of breakage or loss, this must be recorded in the supervisor's report.

After the exam

- The supervisor must complete a report for each practical session held and each laboratory used.
- Each packet of scripts returned to Cambridge International must contain the following items:
 - the scripts of the candidates specified on the bar code label provided
 - the supervisor's results relevant to these candidates
 - the supervisor's reports relevant to these candidates
 - seating plans for each practical session, referring to each candidate by candidate number
 - the attendance register.

Specific information for this practical exam

During the exam, the supervisor (**not** the invigilator) must do the experiments in Questions 1, 2, 3, 4 and 5 and record the results on a spare copy of the question paper, clearly labelled 'supervisor's results'.

Question 1

Each candidate will require:

- (i) approximately 12 cm of dialysis (Visking) tubing of about 14 mm diameter, securely tied at one end with a knot and supplied in tap water (see note 1)
- (ii) 2 cm³ syringe without needle
- (iii) 100 cm³ beaker half-filled with 1% starch solution, labelled **starch solution** (see note 2)
- [MH][N] (iv) 10 cm³ iodine solution in a container accessible with the syringe, labelled **iodine solution** (see note 2)
- (v) stop-clock
- (vi) paper towels.

Notes

1. Prior to the start of the examination, candidates should be shown how to tie a knot in the open end of the tubing.
2. The iodine solution should be diluted if necessary, so that it is an orange colour that is transparent but still be strong enough to indicate the presence of 1% starch.

Question 2

Each candidate will require:

- (i) 30 cm ruler graduated in mm.

For Question 3

Each candidate will require:

- (i) 2g of very small marble chips or powdered calcium carbonate, labelled **calcium carbonate** (see note 1)
- (ii) 40 cm³ of 0.3 mol dm⁻³ hydrochloric acid, labelled **dilute hydrochloric acid**
- (iii) apparatus assembled as in Fig. 3.1 using 100 cm³ measuring cylinder (see note 2)
- (iv) 50 cm³ measuring cylinder
- (v) stop-watch
- (vi) paper towels.

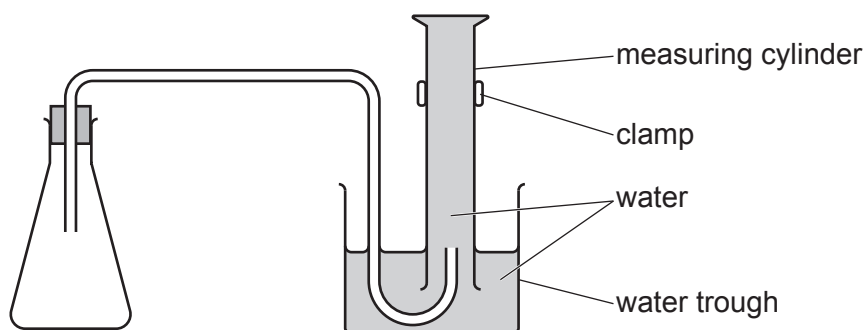

Fig. 3.1

Notes

1. The reaction of 2g of calcium carbonate and 25 cm³ 0.3 mol dm⁻³ hydrochloric acid should take between 2.5 minutes and 4.5 minutes. Please adjust the size of the chips/powder to achieve this.
2. The delivery tube should be made of flexible rubber or plastic.

250 cm³ conical flask is preferred but a 100 cm³ conical flask would be OK.

The measuring cylinder should be filled with water and clamped vertically. There should be enough room in the water trough for the measuring cylinder to empty completely without water overflowing the water trough. Any container of sufficient size for the water not to overflow is acceptable as the water trough.

For Question 4

Each candidate will require:

- [C][MH][N] (i) approximately 25 cm³ of 0.5 mol dm⁻³ aqueous zinc bromide, labelled **solution R**
- (ii) 4 test-tubes (approximately 125 mm × 16 mm) and a means to support them
- [MH][N] (iii) access to 0.1 mol dm⁻³ silver nitrate in a bottle with a dropper or supplied with a dropping pipette, labelled **aqueous silver nitrate**
- (iv) access to 0.1 mol dm⁻³ barium nitrate in a bottle with a dropper or supplied with a dropping pipette, labelled **aqueous barium nitrate**
- [MH][N] (v) approximately 15 cm³ of 1.0 mol dm⁻³ ammonia solution, labelled **aqueous ammonia**
- [C] (vi) approximately 15 cm³ of 1.0 mol dm⁻³ sodium hydroxide solution, labelled **aqueous sodium hydroxide**
- [C] (vii) approximately 10 cm³ of 1.0 mol dm⁻³ dilute nitric acid, labelled **dilute nitric acid**
- (viii) 2 dropping pipettes for use with (v) and (vi)
- (ix) paper towels.

For Question 5

Each candidate will require:

- (i) power source of approximately 3V (see note 1)
- (ii) 3 filament lamps, 2.5V, 0.3A, or similar, in suitable holders (e.g. see www.philipharris.co.uk item B8A56728)
- (iii) switch – this may be an integral part of the power source
- (iv) sufficient connecting leads to set up the circuit shown in Fig. 5.1
- (v) ammeter capable of measuring currents up to 1.00A with a minimum resolution of 0.05A
- (vi) voltmeter capable of measuring up to 3.0V with a minimum resolution of 0.1V.

Notes

1. Where candidates are supplied with a variable power source, the voltage should be set by the supervisor and fixed, e.g. taped. If dry cells are used as the power source, they must remain adequately charged throughout the examination.
2. The circuit is to be set up for candidates as shown in Fig. 5.1. Points **X** and **Y** must be labelled.

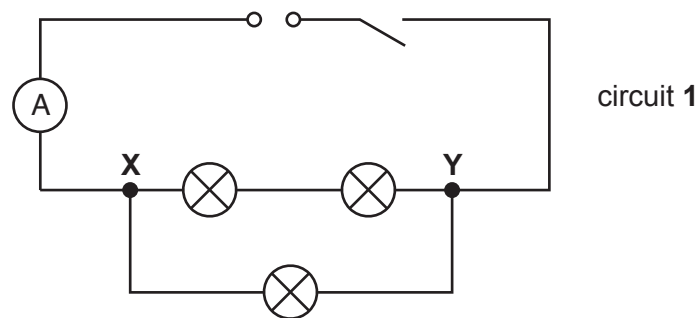

Fig. 5.1

3. Spare lamps and leads should be available.
4. Candidates will be instructed to rearrange the above circuit.
5. Candidates will be required to rearrange and reconnect the given circuit unaided. If help is required, it may be given, but the candidate number must be noted on the supervisor's report.

Action at changeover

Reconnect the circuit shown in Fig. 5.1 **and disconnect the voltmeter.**

For question 6

No apparatus or materials are required for Question 6.

BLANK PAGE

Permission to reproduce items where third-party owned material protected by copyright is included has been sought and cleared where possible. Every reasonable effort has been made by the publisher (UCLES) to trace copyright holders, but if any items requiring clearance have unwittingly been included, the publisher will be pleased to make amends at the earliest possible opportunity.

To avoid the issue of disclosure of answer-related information to candidates, all copyright acknowledgements are reproduced online in the Cambridge Assessment International Education Copyright Acknowledgements Booklet. This is produced for each series of examinations and is freely available to download at www.cambridgeinternational.org after the live examination series.

Cambridge Assessment International Education is part of Cambridge Assessment. Cambridge Assessment is the brand name of the University of Cambridge Local Examinations Syndicate (UCLES), which is a department of the University of Cambridge.

Supervisor's report

Syllabus and component number

				/		
--	--	--	--	---	--	--

Centre number

--	--	--	--	--

Centre name

Time of the practical session

Laboratory name/number

Give details of any difficulties experienced by the centre or by candidates (include the relevant candidate names and candidate numbers).

You must include:

- any difficulties experienced by the centre in the preparation of materials
- any difficulties experienced by candidates, e.g. due to faulty materials or apparatus
- any specific assistance given to candidates.

Declaration

- 1 Each packet that I am returning to Cambridge International contains all of the following items:
 - the scripts of the candidates specified on the bar code label provided
 - the supervisor’s results relevant to these candidates
 - the supervisor’s reports relevant to these candidates
 - seating plans for each practical session, referring to each candidate by candidate number
 - the attendance register.
- 2 Where the practical exam has taken place in more than one practical session, I have clearly labelled the supervisor’s results, supervisor’s reports and seating plans with the time and laboratory name/number for each practical session.
- 3 I have included details of difficulties relating to each practical session experienced by the centre or by candidates.
- 4 I have reported any other adverse circumstances affecting candidates, e.g. illness, bereavement or temporary injury, directly to Cambridge International on a *special consideration form*.

Signed (supervisor)

Name (in block capitals)