



Markscheme

May 2015

Mathematical studies

Standard level

Paper 1

This markscheme is the property of the International Baccalaureate and must **not** be reproduced or distributed to any other person without the authorization of the IB Assessment Centre.

**Paper 1 Markscheme
Instructions to Examiners**

Notes: If in doubt about these instructions or any other marking issues, contact your team leader for clarification.

The number of marks for each question is 6.

1 Abbreviations

The markscheme may make use of the following abbreviations:

- M** Marks awarded for **Method**
- A** Marks awarded for an **Answer** or for **Accuracy**
- C** Marks awarded for **Correct** answers (irrespective of working shown)
- R** Marks awarded for clear **Reasoning**
- ft** Marks that can be awarded as **follow through** from previous results in the question

2 Method of Marking

- (a) All marking must be done in RM Assessor using the mathematical studies annotations and in accordance with the current document for guidance in e-marking Mathematical Studies SL. It is essential that you read this document before you start marking.
- (b) If the candidate has full marks on a question use the **C6** annotation, if the candidate has made an attempt but scores zero marks use **C0**. If there is no attempt use the No response button. If a candidate does not score full or zero marks then full annotations **MUST** be shown.
- (c) In this paper, if the **correct answer is seen on the answer line the** maximum mark is awarded. **There is no need to check the working!** Award **C** marks and move on.
- (d) If the answer does not appear on the answer line, but the correct answer is seen in the working box with no subsequent working, award the maximum mark.
- (e) If the **answer is wrong**, marks should be awarded for the working according to the markscheme.
- (f) Working crossed out by the candidate should not be awarded any marks. Where candidates have written two solutions to a question, only the first solution should be marked.
- (g) A correct answer in the working box transcribed inaccurately to the answer line can receive full marks.
- (h) If correct working results in a correct answer **in the working box** but then further working is developed, indicating a lack of mathematical understanding full marks should **not** be awarded. In most such cases it will be a single final answer mark that is lost, however, a statement on the answer line should always be taken as the candidate's final decision on the answer **as long as it is unambiguous**. An exception to this may be in numerical answers, where a correct exact value is followed by an incorrect decimal.

Example:

	Correct answer seen	Further working seen	Action
1.	$8\sqrt{2}$	5.65685... (incorrect decimal value)	Award the final (A1) (ignore the further working)
2.	$(x - 6)(x + 1)$	$x = 6$ and -1	Do not award the final (A1) (see next example)

Example: Factorise $x^2 - 5x - 6$

Markscheme	Candidates' Scripts	Marking
$(x-6)(x+1)$ (A1)(A1)	(i) Answer line: $(x+6)(x+1)$	(A0)(A1)
	(ii) Working box: $(x-6)(x+1)$ followed by $x=6$ and -1 , or just $6, -1$ in either working box or on answer line.	(A1) (A0)

3 Follow through (ft) Marks

Errors made at any step of a solution affect all working that follows. To limit the severity of the penalty, **follow through (ft)** marks can be awarded. Markschemes will indicate where it is appropriate to apply follow through in a question with '(ft)'.

- Follow through applies only from one part of a question to a subsequent part of the question. Follow through does not apply within the same part.
- If an answer resulting from follow through is extremely unrealistic (eg, negative distances or incorrect by large order of magnitude) then the final **A** mark should not be awarded.
- If a question is transformed by an error into a **different, much simpler question** then follow through may not apply.
- To award follow through marks for a question part, **there must be working present for that part**. An isolated follow through answer, without working is regarded as incorrect and receives no marks **even if it is approximately correct**.
- The exception to the above would be in a question which is testing the candidate's use of the GDC, where working will not be expected. **The markscheme will clearly indicate where this applies**.
- Inadvertent use of radians will be penalised the first time it occurs. The markscheme will give clear instructions to ensure that only one mark per paper can be lost for the use of radians.

Example: Finding angles and lengths using trigonometry

Markscheme	Candidates' Scripts	Marking
(a) $\frac{\sin A}{3} = \frac{\sin 30}{4}$ (M1)(A1)	(a) $\frac{\sin A}{4} = \frac{\sin 30}{3}$	(M1)(A0) (use of sine rule but with wrong values)
$A = 22.0^\circ$ (22.0243...) (A1)	$A = 41.8^\circ$ (Note: the 2 nd (A1) here was not marked (ft) and cannot be awarded because there was an earlier error in the same question part.)	(A0)
(b) $x = 7 \tan (22.0243\dots^\circ)$ (M1) $= 2.83$ (2.83163...) (A1)(ft)	(b) case (i) $x = 7 \tan 41.8^\circ$ $= 6.26$ but case (ii) 6.26	(M1) (A1)(ft) (C0) since no working shown

4 Using the Markscheme

- (a) **A** marks are **dependent** on the preceding **M** mark being awarded, it is **not** possible to award **(M0)(A1)**. Once an **(M0)** has been awarded, all subsequent **A** marks are lost in that part of the question, even if calculations are performed correctly, until the next **M** mark.

The only exception will be for an answer where the accuracy is specified in the question – see section 5.

- (b) **A** marks are **dependent** on the **R** mark being awarded, it is **not** possible to award **(A1)(R0)**. Hence the **(A1)** is not awarded for a correct answer if no reason or the wrong reason is given.

- (c) **Alternative methods** may not always be included. Thus, if an answer is wrong then the working must be carefully analysed in order that marks are awarded for a different method consistent with the markscheme.

Where alternative methods for complete questions are included in the markscheme, they are indicated by '**OR**' etc.

- (d) Unless the question specifies otherwise, accept **equivalent forms**. For example: $\frac{\sin \theta}{\cos \theta}$ for $\tan \theta$.

On the markscheme, these equivalent numerical or algebraic forms will sometimes be written in brackets after the required answer.

Where numerical answers are required as the final answer to a part of a question in the markscheme, the scheme will show, in order:

the 3 significant figure answer worked through from full calculator display;

the exact value $\left(\text{for example } \frac{2}{3} \text{ if applicable} \right)$;

the full calculator display in the form 2.83163... as in the example above.

Where answers are given to 3 significant figures and are then used in subsequent parts of the question leading to a **different** 3 significant figure answer, these solutions will also be given.

- (e) As this is an international examination, all valid **alternative forms of notation** should be accepted. Some examples of these are:

Decimal points: 1.7; 1'7; 1·7; 1,7 .

Decimal numbers less than 1 may be written with or without a leading zero: 0.49 or .49 .

Different descriptions of an interval: $3 < x < 5$; (3, 5);] 3, 5 [.

Different forms of notation for set properties (e.g. complement): A' ; \bar{A} ; A^c ; $U - A$; $(A; U \setminus A$.

Different forms of logic notation: $\neg p$; p' ; \tilde{p} ; \bar{p} ; $\sim p$.

$p \Rightarrow q$; $p \rightarrow q$; $q \Leftarrow p$.

Significance level may be written as α .

- (f) **Discretionary marks**: There will be very rare occasions where the markscheme does not cover the work seen. In such cases the annotation DM should be used to indicate where an examiner has used discretion. Discretion should be used sparingly and if there is doubt an exception should be raised through RM Assessor to the team leader.

As with previous sessions there will be no whole paper penalty marks for accuracy AP, financial accuracy FP and units UP. Instead these skills will be assessed in particular questions and the marks applied according to the rules given in sections 5, 6 and 7 below.

5 Accuracy of Answers

Incorrect accuracy should be penalized once only in each question according to the rules below.

Unless otherwise stated in the question, all numerical answers should be given exactly or correct to 3 significant figures.

1. If the **candidate's answer** is seen to 4 sf or greater **and** would round to the required 3 sf answer, then award **(A1)** and ignore subsequent rounding.

Note: The unrounded answer may appear in either the working box or on the final answer line.

2. If the candidate's unrounded answer is **not** seen then award **(A1)** if the answer given is **correctly** rounded to 2 or more significant figures, otherwise **(A0)**.

Note: If the candidate's unrounded answer is **not** seen and the answer is given correct to 1 sf (correct or not), the answer will be considered wrong and will not count as incorrect accuracy. If this answer is used in subsequent parts, then working must be shown for further marks to be awarded.

3. If a correct 2 sf answer is used in subsequent parts, then working **must** be shown for further marks to be awarded. (This treatment is the same as for following through from an incorrect answer.)

These 3 points (see numbers in superscript) have been summarized in the table below and illustrated in the examples which follow.

		If candidates final answer is given ...					
		Exact or to 4 or more sf (and would round to the correct 3 sf)	Correct to 3 sf	Incorrect to 3 sf	Correct to 2 sf ³	Incorrect to 2 sf	Correct or incorrect to 1 sf
Unrounded answer seen ¹		Award the final (A1) irrespective of correct or incorrect rounding					
Unrounded answer not seen ²		(A1)	(A1)	(A0)	(A1)	(A0)	(A0)
Treatment of subsequent parts		As per MS		Treat as follow through, only if working is seen. ³			

Examples:

Markscheme	Candidates' Scripts	Marking
9.43 (9.43398...) (A1)	(i) 9.43398... is seen in the working box followed by 9; 9.4; 9.43; 9.434 etc. (correctly rounded)	(A1)
	(ii) 9.43398... is seen in the working box followed by 9.433; 9.44 etc. (incorrectly rounded)	(A1)
	(iii) 9.4	(A1)
	(iv) 9	(A0) <i>(correct to 1 sf)</i>
	(v) 9.3	(A0) <i>(incorrectly rounded to 2 sf)</i>
	(vi) 9.44	(A0) <i>(incorrectly rounded to 3 sf)</i>

Markscheme	Candidates' Scripts	Marking
7.44 (7.43798...) (A1)	(i) 7.43798... is seen in the working box followed by 7; 7.4; 7.44; 7.438 etc. (correctly rounded)	(A1)
	(ii) 7.43798... is seen in the working box followed by 7.437; 7.43 etc. (incorrectly rounded)	(A1)
	(iii) 7.4	(A1)
	(iv) 7	(A0) <i>(correct to 1 sf)</i>
	(v) 7.5	(A0) <i>(incorrectly rounded to 2 sf)</i>
	(vi) 7.43	(A0) <i>(incorrectly rounded to 3 sf)</i>

Example: ABC is a right angled triangle with angle $ABC = 90^\circ$, $AC = 32$ cm and $AB = 30$ cm. Find (a) the length of BC, (b) The area of triangle ABC.

Markscheme	Candidates' Scripts	Marking
(a) $BC = \sqrt{32^2 - 30^2}$ (M1) Award (M1) for correct substitution in Pythagoras' formula $= 11.1 (\sqrt{124}, 11.1355\dots)$ (cm) (A1)	(a) $BC = \sqrt{32^2 - 30^2}$ 11 (cm) <i>(2 sf answer only seen, but correct)</i>	(M1) (A1)
(b) $\text{Area} = \frac{1}{2} \times 30 \times 11.1355\dots$ (M1) Award (M1) for correct substitution in area of triangle formula $= 167(167.032\dots)$ (cm ²) (A1)(ft)	(b) case (i) $\text{Area} = \frac{1}{2} \times 30 \times 11$ $= 165$ (cm ²) case (ii) $= 165$ (cm ²) <i>(No working shown, the answer 11 is treated as a ft, so no marks awarded here)</i>	(M1) <i>(working shown)</i> (A1)(ft) (M0)(A0)(ft)

Rounding of an exact answer to 3 significant figures **should be accepted if performed correctly**.

Exact answers such as $\frac{1}{4}$ can be written as decimals to fewer than 3 significant figures if the result is still exact. Reduction of a fraction to its lowest terms is **not** essential, however where an answer simplifies to an integer this is expected.

Ratios of π and answers taking the form of square roots of integers or any rational power of an integer (e.g. $\sqrt{13}, 2^{\frac{3}{4}}, \sqrt[4]{5}$,) may be accepted as exact answers. All other powers (eg, of non-integers) and values of transcendental functions such as sine and cosine must be evaluated.

If the level of accuracy is specified in the question, a mark will be allocated for giving the answer to the required accuracy. In **all** such cases the final mark is not awarded if the rounding does not follow the instructions given in the question. A mark for specified accuracy can be regarded as a **(ft)** mark regardless of an immediately preceding **(M0)**.

Certain answers obtained from the GDC are worth 2 marks and working will not be seen. In these cases only one mark should be lost for accuracy.

eg, Chi-squared, correlation coefficient, mean

Markscheme	Candidates' Scripts	Marking
Chi-squared	(a) 7.7	(A2)
7.68 (7.67543...)	(b) 7.67	(A1)
(A2)	(c) 7.6	(A1)
	(d) 8	(A0)
	(e) 7	(A0)
	(e) 7.66	(A0)

Regression line

Markscheme	Candidates' Scripts	Marking
$y = 0.888x + 13.5$	(a) $y = 0.89x + 13$	(A2)
$(y = 0.887686...x + 13.4895...)$		<i>(both accepted)</i>
If an answer is not in the form of an equation award at most (A1)(A0) .	(b) $y = 0.88x + 13$	(A1)
		<i>(one rounding error)</i>
	(c) $y = 0.88x + 14$	(A1)
		<i>(rounding error repeated)</i>
	(d) (i) $y = 0.9x + 13$	
	(ii) $y = 0.8x + 13$	(A1)
		<i>(1 sf not accepted)</i>
	(e) $0.88x + 14$	(A0)
		<i>(two rounding errors and not an equation)</i>

Maximum/minimum/points of intersection

Markscheme	Candidates' Scripts	Marking
(2.06, 4.49)	(a) (2.1, 4.5)	(A1)(A1)
(A1)(A1)		<i>(both accepted)</i>
(2.06020..., 4.49253...)	(b) (2.0, 4.4)	(A1)
		<i>(same rounding error twice)</i>
	(c) (2.06, 4.4)	(A1)
		<i>(one rounding error)</i>
	(d) (2, 4.4)	(A0)
		<i>(1sf not accepted, one rounding error)</i>

6 Level of accuracy in finance questions

The accuracy level required for answers will be specified in all questions involving money. This will usually be either whole units or two decimal places. The first answer not given to the specified level of accuracy will not be awarded the final **A** mark. The markscheme will give clear instructions to ensure that only one mark per paper can be lost for incorrect accuracy in a financial question.

Example: A financial question demands accuracy correct to 2 dp.

Markscheme	Candidates' Scripts	Marking
\$231.62 (231.6189) (A1)	(i) 231.6	(A0)
	(ii) 232	(A0) <i>(Correct rounding to incorrect level)</i>
	(iii) 231.61	(A0)
	(iv) 232.00	(A0) <i>(Parts (iii) and (iv) are both incorrect rounding to correct level)</i>

7 Units in answers

There will be specific questions for which the units are required and this will be indicated clearly in the markscheme. The first correct answer with no units or incorrect units will not be awarded the final **A** mark. The markscheme will give clear instructions to ensure that only one or two marks per paper can be lost for lack of units or incorrect units.

The units are considered only when the numerical answer is awarded **(A1)** under the accuracy rules given in Section 5.

Markscheme	Candidates' Scripts	Marking
(a) 37000 m ² (A1)	(a) 36000 m ²	(A0) <i>(Incorrect answer so units not considered)</i>
(b) 3200 m ³ (A1)	(b) 3200 m ²	(A0) <i>(Incorrect units)</i>

If no method is shown and the answer is correct but with incorrect or missing units award the C marks with a one mark penalty.

8 Graphic Display Calculators

Candidates will often obtain solutions directly from their calculators. They must use mathematical notation, not calculator notation. No method marks can be awarded for incorrect answers supported only by calculator notation. The comment "I used my GDC" cannot receive a method mark.

1. (a) $\sqrt{(100-1)^2 + (200+2)^2}$ (M1)
 $\sqrt{50605}$ (= 224.955...) (A1)

Note: Award (M1)(A1) if $\sqrt{50605}$ seen.

224.96 (A1) (C3)
)

Note: Award (A1) for their answer given correct to 2 decimal places.

(b) 225 (A1)(ft) (C1)

Note: Follow through from their part (a).

(c) 2.25×10^2
 (A1)(ft)(A1)(ft) (C2)

Notes: Award (A1)(A0) for 2.25 and an incorrect index value.
 Award (A0)(A0) for answers such as 22.5×10^1 .

[6 marks]

2. (a)

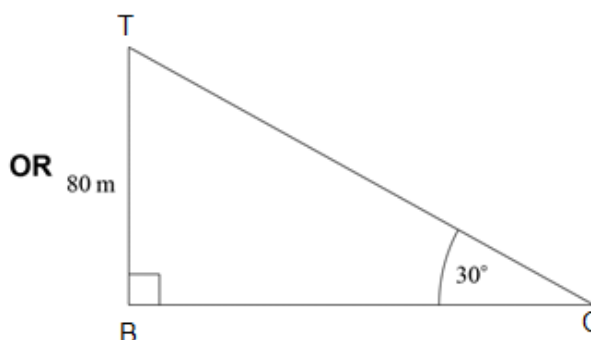
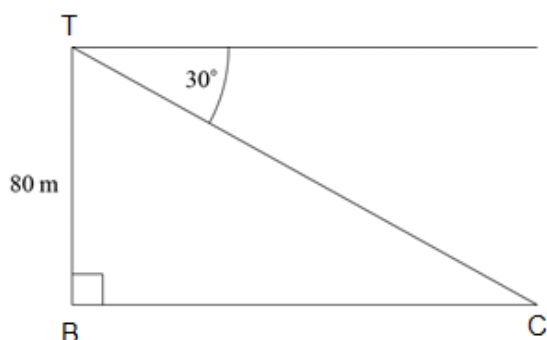
**(A1)(A1)****(C2)**

Notes: Award **(A1)** for 80 m in the correct position on diagram.
Award **(A1)** for 30° in a correct position on diagram.

(b) $\tan 30^\circ = \frac{80}{BC}$ OR $\tan 60^\circ = \frac{BC}{80}$ OR $\frac{80}{\sin 30^\circ} = \frac{BC}{\sin 60^\circ}$ **(M1)**

Note: Award **(M1)** for a correct trigonometric or Pythagorean equation for BC with correctly substituted values.

(BC =) 139(m) (138.564... (m))

(A1)(ft)**(C2)**

Notes: Accept an answer of $80\sqrt{3}$ which is the exact answer.
Follow through from part (a).
Do not penalize use of radians unless it leads to a negative answer.

(c) $\left| \frac{150 - 138.564...}{138.564...} \right| \times 100$ **(M1)**

Notes: Award **(M1)** for their correct substitution into the percentage error formula.

= 8.25(%) (8.25317...%)

(A1)(ft)**(C2)**

Notes: Accept 7.91(%) (7.91366...) if 139 is used.
Accept 8.23(%) (8.22510...) if 138.6 is used.
Follow through from their answer to part (b).
If answer to part (b) is 46.2, answer to part (c) is 225% , award **(M1)(A1)(ft)** with or without working seen. If answer to part (b) is negative, award at most **(M1)(A0)**.

[6 marks]

3. (a) (i) -2 (A1) (C1)
 (ii) 10 (A1) (C1)
- (b) $2x + y - 3 = 0$ (A1)(ft)(A1) (C2)

Notes: Award (A1)(ft) for gradient, (A1) for correct y-intercept.
 The answer must be an equation.

- (c) $-2x + 3 = 0$ or equivalent (M1)
 $(x =) 1.5$
 (A1)(ft) (C2)

Notes: Follow through from their equation in part (b). If answer given as coordinates $(1.5, 0)$ award at most (M1)(A0) if working seen or (A1)(A0) if no working seen.

[6 marks]

4. (a) 4 (A1)(C1)

(b)

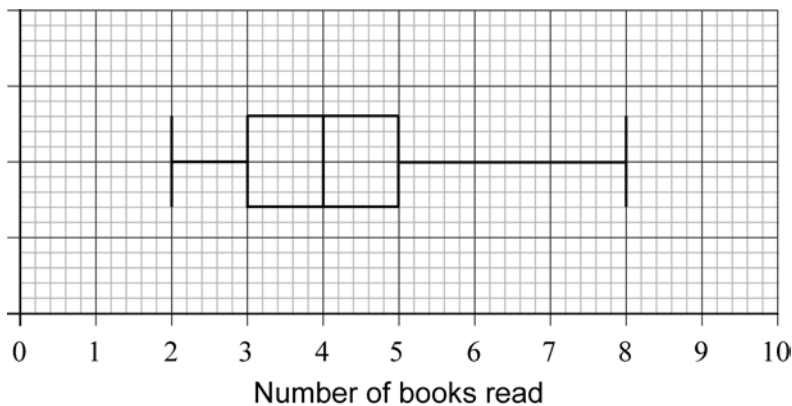

(A1)(ft)(A1)(A1) (C3)

Notes: Award (A1)(ft) for correct median, (A1) for correct quartiles and box, (A1) for endpoints 2 and 8 joined by a straight line that does not cross the box. Follow through from their median from part (a).

- (c) 40×0.25 (M1)

Notes: Award (M1) for $40 \times 25\%$ OR $40 - 40 \times 75\%$.

10
 (A1) (C2)

[6 marks]

5. (a)

r	p	q	$r \wedge p$	$\neg q$	$(r \wedge p) \vee \neg q$	$\neg((r \wedge p) \vee \neg q)$	$\neg(r \wedge p)$	$\neg(r \wedge p) \wedge q$
T	T	T	T	F	T	F	F	F
T	T	F	T	T	T	F	F	F
T	F	T	F	F	F	T	T	T
T	F	F	F	T	T	F	T	F
F	T	T	F	F	F	T	T	T
F	T	F	F	T	T	F	T	F
F	F	T	F	F	F	T	T	T
F	F	F	F	T	T	F	T	F

(A1)(A1)(ft)(A1)(ft)(A1) (C4)

Notes: Award **(A1)** for each correct column.
 For the " $(r \wedge p) \vee \neg q$ " follow through from the " $r \wedge p$ " column.
 For the " $\neg((r \wedge p) \vee \neg q)$ " column, follow through from the preceding column.

(b) tautology
 columns $\neg((r \wedge p) \vee \neg q)$ and $\neg(r \wedge p) \wedge q$ are identical

(A1)(ft)
(R1)(C2)

Notes: Do not award **(R0)(A1)(ft)**. Follow through from their table in part (a).
 Award the **(R1)** for an additional column representing
 $\neg((r \wedge p) \vee \neg q) \Leftrightarrow (\neg(r \wedge p) \wedge q)$ that is consistent with their table.

[6 marks]

6.

Set	Diagram
$(A \cup B)'$	3
$A' \cup B'$	1
$A \cap B'$	2
$A \cap B$	6
$A' \cup B$	5
A'	4

(A6)(C6)

Note: Award **(A1)** for each correct entry.

[6 marks]

7. (a) H_0 = the type of Latin dance the viewer prefers is independent of their age **(A1) (C1)**

Notes: Accept “not dependent” or “not associated”. Do not accept “not correlated” or “not related” or “not connected”.

- (b) 18
(A1) (C1)

- (c) $p = 0.0876$ (0.0875813...)
(A2) (C2)

Notes: Award **(A2)** for 0.088.
Award **(A1)(A0)** for an answer of 0.0875.

- (d) $0.05 <$ their p -value **(R1)**

justified the producer's claim is
(A1)(ft) (C2)

Notes: Do not award **(R0)(A1)(ft)**. Follow through from their answer to (c). If there is no answer in part (c), award **(R1)(A0)** for stating the relationship between the independence **and** the p -value compared to 0.05. If **(R1)** is awarded, award **(A1)(ft)** for the answer ‘yes’ or the answer ‘no’ if it is consistent with their reasoning. Similarly, allow ‘accept H_0 ’ or ‘reject H_0 ’ if consistent with their reasoning. Award **(R0)** for comparing p with the critical value.

[6 marks]

8. (a) 10m (A1)(C1)

(b) $\hat{A}MC = 70^\circ$ OR $\hat{A}CM = 55^\circ$ (A1)

$\hat{C}MB = 110^\circ$
(A1) (C2)

(c) $CB^2 = 10^2 + 10^2 - 2 \times 10 \times 10 \times \cos 110^\circ$ (M1)(A1)(ft)

Notes: Award (M1) for substitution into the cosine rule formula, (A1)(ft) for correct substitution. Follow through from their answer to part (b).

OR

$$\frac{CB}{\sin 110^\circ} = \frac{10}{\sin 35^\circ} \quad (M1)(A1)(ft)$$

Notes: Award (M1) for substitution into the sine rule formula, (A1)(ft) for correct substitution. Follow through from their answer to part (b).

OR

$$\hat{A}CB = 90^\circ \quad (A1)$$

$$\sin 55^\circ = \frac{CB}{20} \quad \text{OR} \quad \cos 35^\circ = \frac{CB}{20} \quad (M1)$$

Note: Award (A1) for some indication that $\hat{A}CB = 90^\circ$, (M1) for correct trigonometric equation.

OR

Perpendicular MN is drawn from M to CB. (A1)

$$\frac{\frac{1}{2}CB}{10} = \cos 35^\circ \quad (M1)$$

Note: Award (A1) for some indication of the perpendicular bisector of BC, (M1) for correct trigonometric equation.

$CB = 16.4(\text{m}) (16.3830\dots(\text{m}))$ (A1)(ft)(C3)

Notes: Where a candidate uses $\hat{C}MB = 90^\circ$ and finds $CB = 14.1$ (m) award, at most, (M1)(A1)(A0).
Where a candidate uses $\hat{C}MB = 60^\circ$ and finds $CB = 10$ (m) award, at most, (M1)(A1)(A0).

[6 marks]

9. (a) (i) d_n **OR** 1, 0.95, 0.90, 0.85, ... **(A1)** **(C1)**
 (ii) b_n **OR** $1, \frac{3}{2}, \frac{9}{4}, \frac{27}{8}, \dots$
(A1) (C1)

- (b) (i) $\frac{1}{2}$ **OR**
 0.5 **(A1) (C1)**

Note: Accept 'divide by 2' for **(A1)**.

(ii) $-6\left(\frac{1}{2}\right)^{10-1}$ **(M1)(A1)(ft)**

Notes: Award **(M1)** for substitution in the GP n^{th} term formula,
(A1)(ft) for their correct substitution.
 Follow through from their common ratio in part (b)(i).

OR

$\left(-6, -3, -\frac{3}{2}, -\frac{3}{4}\right), -\frac{3}{8}, -\frac{3}{16}, -\frac{3}{32}, -\frac{3}{64}, -\frac{3}{128}$ **(M1)(A1)(ft)**

Notes: Award **(M1)** for terms 5 and 6 correct (using their ratio).
 Award **(A1)(ft)** for terms 7, 8 and 9 correct (using their ratio).

$-\frac{3}{256} \left(-\frac{6}{512}\right)$
(A1)(ft) **(C3)**

[6 marks]

10. (a) $1000\left(1 + \frac{5}{4 \times 100}\right)^{4 \times 3}$ **(M1)(A1)**

Note: Award **(M1)** for substitution into compound interest formula, **(A1)** for correct substitution.

OR

$$N = 3$$

$$I\% = 5$$

$$PV = -1000$$

$$P/Y = 1$$

$$C/Y = 4$$

(A1)(M1)

Note: Award **(A1)** for $C/Y = 4$ seen, **(M1)** for other correct entries.

OR

$$N = 12$$

$$I\% = 5$$

$$PV = -1000$$

$$P/Y = 4$$

$$C/Y = 4$$

(A1)(M1)

Note: Award **(A1)** for $C/Y = 4$ seen, **(M1)** for other correct entries.

(€) $\begin{matrix} = 1160.75 \\ \textbf{(A1)} \quad \textbf{(C3)} \end{matrix}$

(b) $1000\left(1 + \frac{5}{4 \times 100}\right)^{4 \times t} = 1300$ **(M1)(A1)**

Note: Award **(M1)** for using the compound interest formula with a variable for time, **(A1)** for substituting correct values and equating to 1300.

continued...

Question 10 continued

OR

$$I\% = 5$$

$$PV = \pm 1000$$

$$FV = \mp 1300$$

$$P/Y = 1$$

$$C/Y = 4$$

(A1)(M1)

Note: Award **(A1)** for 1300 seen, **(M1)** for the other correct entries.

OR

$$I\% = 5$$

$$PV = \pm 1000$$

$$FV = \mp 1300$$

$$P/Y = 4$$

$$C/Y = 4$$

(A1)(M1)

Note: Award **(A1)** for 1300 seen, **(M1)** for the other correct entries.

OR

Sketch drawn of two appropriate lines which intersect at a point

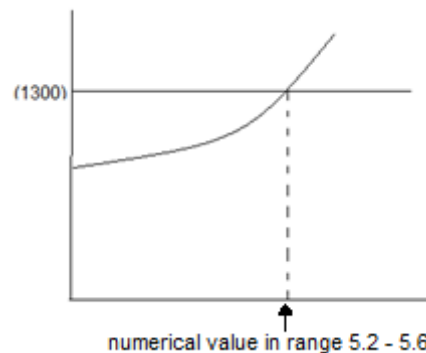

Note: Award **(M1)** for a sketch with a straight line intercepted by appropriate curve, **(A1)** for a numerical answer in the range 5.2 – 5.6.

$$t = 5.28 \text{ (years) (5.28001...)}$$

(A1) (C3)

[6 marks]

11. (a) x is not a multiple of 12 (A1) (C1)

(b) $p \Rightarrow q$ (A1)(A1)(C2)

Note: Award (A1) for \Rightarrow , (A1) for p and q in the correct order.
Accept $q \Leftarrow p$.

(c) Converse (A1) (C1)
)

(d) not valid (A1)
for example 18 is a multiple of 6 and not a multiple of
12 (R1) (C2)

Notes: Do not award (A1)(R0). Any multiple of 6 that is not a multiple of 12 can be accepted as a counterexample.

[6 marks]

12. (a) $AO = 4$ (cm) (A1) (C1)

(b) $\cos \hat{OAV} = \frac{4}{10}$ (M1)

Note: Award (M1) for their correct trigonometric ratio.

OR

$$\cos \hat{OAV} = \frac{10^2 + 8^2 - 10^2}{2 \times 10 \times 8} \quad \text{OR} \quad \frac{10^2 + 4^2 - (9.16515\dots)^2}{2 \times 10 \times 4} \quad (M1)$$

Note: Award (M1) for correct substitution into the cosine rule formula.

$$\hat{OAV} = 66.4^\circ \quad (66.4218\dots) \quad (A1)(ft) \quad (C2)$$

Notes: Follow through from their answer to part (a).

(c) $\text{area} = \frac{8 \times 10 \times \sin(66.4218\dots^\circ)}{2}$ OR $\frac{1}{2} \times 8 \times \sqrt{10^2 - 4^2}$

OR $\frac{1}{2} \times 10 \times 10 \times \sin(47.1563\dots^\circ)$ (M1)(A1)(ft)

Notes: Award (M1) for substitution into the area formula, (A1)(ft) for correct substitutions. Follow through from their answer to part (b) and/or part (a).

$$\text{area} = 36.7 \text{ cm}^2 \quad (36.6606\dots \text{cm}^2) \quad (A1)(ft) \quad (C3)$$

Notes: Accept an answer of $8\sqrt{21} \text{ cm}^2$ which is the exact answer.

[6 marks]

13. (a)

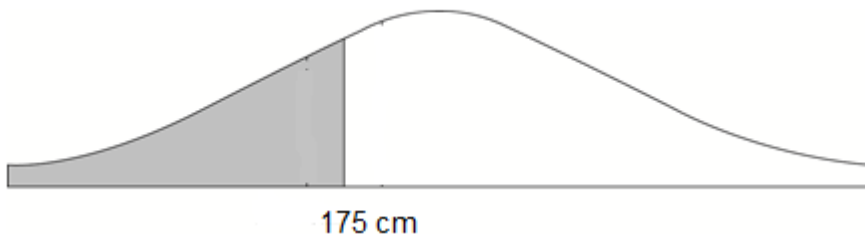
**(A1)(M1)****(C2)**

Notes: Award **(A1)** for the vertical line labelled as 175 (cm).
 Award **(M1)** for a vertical line drawn to the left of the mean with the area to the left of this line shaded.
 Accept (-1) sd marked on the diagram for 175 (provided line is to the left of the mean).

(b) (i) 185(cm)

(A1)(C1)(ii) $P(\text{length} > 185)$ **(A1)(M1)**

Note: Award **(A1)** for the vertical line labelled as 185 (cm).
 Award **(M1)** for a vertical line drawn to the right of the mean with the area to the right of this line shaded.
 Accept 1 sd marked on the diagram for 185 (provided line is to the right of the mean).

$$= 0.159 \text{ (0.158655...)}$$

(A1) (C3)**[6 marks]**

14. (a) $ab^0 + 40 = 840$ (M1)

Note: Award (M1) for substituting $t = 0$ and equating to 840.

$a = 800$ (A1)(C2)

(b) $800b^{-4} + 40 = 90$ (M1)

Note: Award (M1) for correct substitution of their a (from part (a)) and 4 in the formula of the function and equating to 90.

$b^4 = 16$ OR $\frac{1}{b^4} = \frac{1}{16}$ OR $b = \sqrt[4]{16}$ OR $b = 16^{\frac{1}{4}}$ (M1)

Notes: Award second (M1) for correctly rearranging their equation and eliminating the negative index (see above examples).

Accept $\frac{800}{50}$ in place of 16.

OR

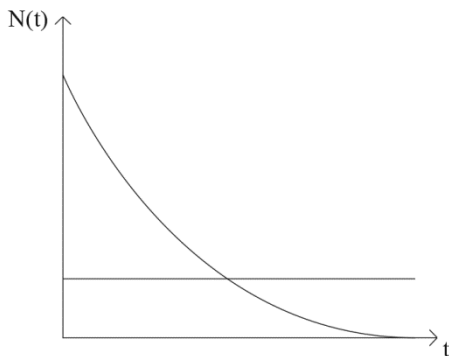

(M1)(M1)

Notes: Award (M1) for a decreasing exponential and a horizontal line that are both in the first quadrant, and (M1) for their graphs intersecting.
For graphs drawn in both first and second quadrants award at most (M1)(M0).

$b = 2$
(A1)(ft) (C3)

Note: Follow through from their answer to part (a) only if a is positive.

(c) 40 (A1) (C1)

[6 marks]

15. (a) $3600 \text{ (m}^2\text{)}$ **(A1)(C1)**

(b) $x(200 - x) = 3600$ **(M1)**

Note: Award **(M1)** for setting up an equation, equating to their 3600.

180 (m)

(A1)(ft) (C2)

Note: Follow through from their answer to part (a).

(c) (i) 100 (m)

(A1) (C1)

(ii) 10000 (m²)

(A1)(ft)(C1)

Note: Follow through from their answer to part (c)(i).

(d) $m = 3600$

and

$n = 10000$

(A1)(ft) (C1)

Notes: Follow through from part (a) and part (c)(ii), but only if their m is less than their n . Accept the answer $3600 \leq A \leq 10000$.

[6 marks]
