



Markscheme

May 2019

Mathematical studies

Standard level

Paper 1

No part of this product may be reproduced in any form or by any electronic or mechanical means, including information storage and retrieval systems, without written permission from the IB.

Additionally, the license tied with this product prohibits commercial use of any selected files or extracts from this product. Use by third parties, including but not limited to publishers, private teachers, tutoring or study services, preparatory schools, vendors operating curriculum mapping services or teacher resource digital platforms and app developers, is not permitted and is subject to the IB's prior written consent via a license. More information on how to request a license can be obtained from <http://www.ibo.org/contact-the-ib/media-inquiries/for-publishers/guidance-for-third-party-publishers-and-providers/how-to-apply-for-a-license>.

Aucune partie de ce produit ne peut être reproduite sous quelque forme ni par quelque moyen que ce soit, électronique ou mécanique, y compris des systèmes de stockage et de récupération d'informations, sans l'autorisation écrite de l'IB.

De plus, la licence associée à ce produit interdit toute utilisation commerciale de tout fichier ou extrait sélectionné dans ce produit. L'utilisation par des tiers, y compris, sans toutefois s'y limiter, des éditeurs, des professeurs particuliers, des services de tutorat ou d'aide aux études, des établissements de préparation à l'enseignement supérieur, des fournisseurs de services de planification des programmes d'études, des gestionnaires de plateformes pédagogiques en ligne, et des développeurs d'applications, n'est pas autorisée et est soumise au consentement écrit préalable de l'IB par l'intermédiaire d'une licence. Pour plus d'informations sur la procédure à suivre pour demander une licence, rendez-vous à l'adresse <http://www.ibo.org/fr/contact-the-ib/media-inquiries/for-publishers/guidance-for-third-party-publishers-and-providers/how-to-apply-for-a-license>.

No se podrá reproducir ninguna parte de este producto de ninguna forma ni por ningún medio electrónico o mecánico, incluidos los sistemas de almacenamiento y recuperación de información, sin que medie la autorización escrita del IB.

Además, la licencia vinculada a este producto prohíbe el uso con fines comerciales de todo archivo o fragmento seleccionado de este producto. El uso por parte de terceros —lo que incluye, a título enunciativo, editoriales, profesores particulares, servicios de apoyo académico o ayuda para el estudio, colegios preparatorios, desarrolladores de aplicaciones y entidades que presten servicios de planificación curricular u ofrezcan recursos para docentes mediante plataformas digitales— no está permitido y estará sujeto al otorgamiento previo de una licencia escrita por parte del IB. En este enlace encontrará más información sobre cómo solicitar una licencia: <http://www.ibo.org/es/contact-the-ib/media-inquiries/for-publishers/guidance-for-third-party-publishers-and-providers/how-to-apply-for-a-license>.

**Paper 1 Markscheme
Instructions to Examiners**

Notes: If in doubt about these instructions or any other marking issues, contact your team leader for clarification.

The number of marks for each question is 6.

1 Abbreviations

The markscheme may make use of the following abbreviations:

- M** Marks awarded for **Method**
- A** Marks awarded for an **Answer** or for **Accuracy**
- C** Marks awarded for **Correct** answers (irrespective of working shown)
- R** Marks awarded for clear **Reasoning**
- ft** Marks that can be awarded as **follow through** from previous results in the question

2 Method of Marking

- (a) All marking must be done in RM Assessor using the mathematical studies annotations and in accordance with the current document for guidance in e-marking Mathematical Studies SL. It is essential that you read this document before you start marking.
- (b) If the candidate has full marks on a question use the **C6** annotation, if the candidate has made an attempt but scores zero marks use **C0**. If there is no attempt use the No response button. If a candidate does not score full or zero marks then full annotations **MUST** be shown.
- (c) In this paper, if the **correct answer is seen on the answer line the** maximum mark is awarded. **There is no need to check the working!** Award **C** marks and move on.
- (d) If the answer does not appear on the answer line, but the correct answer is seen in the working box with no subsequent working, award the maximum mark.
- (e) If the **answer is wrong**, marks should be awarded for the working according to the markscheme.
- (f) Working crossed out by the candidate should not be awarded any marks. Where candidates have written two solutions to a question, only the first solution should be marked.
- (g) A correct answer in the working box transcribed inaccurately to the answer line can receive full marks.
- (h) If correct working results in a correct answer **in the working box** but then further working is developed, indicating a lack of mathematical understanding full marks should **not** be awarded. In most such cases it will be a single final answer mark that is lost, however, a statement on the answer line should always be taken as the candidate's final decision on the answer **as long as it is unambiguous**. An exception to this may be in numerical answers, where a correct exact value is followed by an incorrect decimal.

Example:

	Correct answer seen	Further working seen	Action
1.	$8\sqrt{2}$	5.65685... (incorrect decimal value)	Award the final (A1) (ignore the further working)
2.	$(x-6)(x+1)$	$x=6$ and -1	Do not award the final (A1) (see next example)

Example: Factorise $x^2 - 5x - 6$

Markscheme	Candidates' Scripts	Marking
$(x-6)(x+1)$ (A1)(A1)	(i) Answer line: $(x+6)(x+1)$	(A0)(A1)
	(ii) Working box: $(x-6)(x+1)$ followed by $x=6$ and -1 , or just $6, -1$ in either working box or on answer line.	(A1)
		(A0)

3 Follow through (ft) Marks

Errors made at any step of a solution affect all working that follows. To limit the severity of the penalty, **follow through (ft)** marks can be awarded. Markschemes will indicate where it is appropriate to apply follow through in a question with '**ft**'.

- Follow through applies only from one part of a question to a subsequent part of the question. Follow through does not apply within the same part.
- If an answer resulting from follow through is extremely unrealistic (eg, negative distances or incorrect by large order of magnitude) then the final **A** mark should not be awarded.
- If a question is transformed by an error into a **different, much simpler question** then follow through may not apply.
- To award follow through marks for a question part, **there must be working present for that part**. An isolated follow through answer, without working is regarded as incorrect and receives no marks **even if it is approximately correct**.
- The exception to the above would be in a question which is testing the candidate's use of the GDC, where working will not be expected. **The markscheme will clearly indicate where this applies**.
- Inadvertent use of radians will be penalised the first time it occurs. The markscheme will give clear instructions to ensure that only one mark per paper can be lost for the use of radians.

Example: Finding angles and lengths using trigonometry

Markscheme	Candidates' Scripts	Marking
(a) $\frac{\sin A}{3} = \frac{\sin 30}{4}$ (M1)(A1) $A = 22.0^\circ$ (22.0243...) (A1)	(a) $\frac{\sin A}{4} = \frac{\sin 30}{3}$	(M1)(A0) <i>(use of sine rule but with wrong values)</i>
	$A = 41.8^\circ$ <i>(Note: the 2nd (A1) here was not marked (ft) and cannot be awarded because there was an earlier error in the same question part.)</i>	(A0)
(b) $x = 7 \tan (22.0243\dots^\circ)$ (M1) $= 2.83$ (2.83163...) (A1)(ft)	(b) case (i) $x = 7 \tan 41.8^\circ$ $= 6.26$ but case (ii) 6.26	(M1) (A1)(ft) (C0) <i>since no working shown</i>

4 Using the Markscheme

(a) **A** marks are **dependent** on the preceding **M** mark being awarded, it is **not** possible to award **(M0)(A1)**. Once an **(M0)** has been awarded, all subsequent **A** marks are lost in that part of the question, even if calculations are performed correctly, until the next **M** mark.
The only exception will be for an answer where the accuracy is specified in the question – see section 5.

(b) **A** marks are **dependent** on the **R** mark being awarded, it is **not** possible to award **(A1)(R0)**. Hence the **(A1)** is not awarded for a correct answer if no reason or the wrong reason is given.

(c) **Alternative methods** may not always be included. Thus, if an answer is wrong then the working must be carefully analysed in order that marks are awarded for a different method consistent with the markscheme.
Where alternative methods for complete questions are included in the markscheme, they are indicated by '**OR**' etc.

(d) Unless the question specifies otherwise, accept **equivalent forms**. For example: $\frac{\sin \theta}{\cos \theta}$ for $\tan \theta$.

On the markscheme, these equivalent numerical or algebraic forms will sometimes be written in brackets after the required answer.

Where numerical answers are required as the final answer to a part of a question in the markscheme, the scheme will show, in order:

the 3 significant figure answer worked through from full calculator display;

the exact value $\left(\text{for example } \frac{2}{3} \text{ if applicable} \right)$;

the full calculator display in the form 2.83163... as in the example above.

Where answers are given to 3 significant figures and are then used in subsequent parts of the question leading to a **different** 3 significant figure answer, these solutions will also be given.

(e) As this is an international examination, all valid **alternative forms of notation** should be accepted. Some examples of these are:

Decimal points: 1.7; 1'7; 1·7; 1,7 .

Decimal numbers less than 1 may be written with or without a leading zero: 0.49 or .49 .

Different descriptions of an interval: $3 < x < 5$; (3, 5);] 3, 5 [.

Different forms of notation for set properties (e.g. complement): A' ; \bar{A} ; A^c ; $U - A$; $(A; U \setminus A$.

Different forms of logic notation: $\neg p$; p' ; \bar{p} ; \bar{p} ; $\sim p$; $-p$.

$p \Rightarrow q$; $p \rightarrow q$; $q \Leftarrow p$.

Significance level may be written as α .

(f) Discretionary marks: There will be very rare occasions where the markscheme does not cover the work seen. In such cases the annotation DM should be used to indicate where an examiner has used discretion. Discretion should be used sparingly and if there is doubt an exception should be raised through RM Assessor to the team leader.

As with previous sessions there will be no whole paper penalty marks for accuracy AP, financial accuracy FP and units UP. Instead these skills will be assessed in particular questions and the marks applied according to the rules given in sections 5, 6 and 7 below.

5 Accuracy of Answers

Incorrect accuracy should be penalized once only in each question according to the rules below.

Unless otherwise stated in the question, all numerical answers should be given exactly or correct to 3 significant figures.

1. If the **candidate's answer** is seen to 4 sf or greater **and** would round to the required 3 sf answer, then award **(A1)** and ignore subsequent rounding.

Note: The unrounded answer may appear in either the working box or on the final answer line.

2. If the candidate's unrounded answer is **not** seen then award **(A1)** if the answer given is **correctly** rounded to 2 or more significant figures, otherwise **(A0)**.

Note: If the candidate's unrounded answer is **not** seen and the answer is given correct to 1 sf (correct or not), the answer will be considered wrong and will not count as incorrect accuracy. If this answer is used in subsequent parts, then working must be shown for further marks to be awarded.

3. If a correct 2 sf answer is used in subsequent parts, then working **must** be shown for further marks to be awarded. (This treatment is the same as for following through from an incorrect answer.)

These 3 points (see numbers in superscript) have been summarized in the table below and illustrated in the examples which follow.

	If candidates final answer is given ...					
	Exact or to 4 or more sf (and would round to the correct 3 sf)	Correct to 3 sf	Incorrect to 3 sf	Correct to 2 sf ³	Incorrect to 2 sf	Correct or incorrect to 1 sf
Unrounded answer seen ¹	Award the final (A1) irrespective of correct or incorrect rounding					
Unrounded answer not seen ²	(A1)	(A1)	(A0)	(A1)	(A0)	(A0)
Treatment of subsequent parts	As per MS		Treat as follow through, only if working is seen. ³			

Examples:

Markscheme	Candidates' Scripts	Marking
9.43 (9.43398...) (A1)	(i) 9.43398... is seen in the working box followed by 9; 9.4; 9.43; 9.434 etc. (correctly rounded)	(A1)
	(ii) 9.43398... is seen in the working box followed by 9.433; 9.44 etc. (incorrectly rounded)	(A1)
	(iii) 9.4	(A1)
	(iv) 9	(A0) (correct to 1 sf)
	(v) 9.3	(A0) (incorrectly rounded to 2 sf)
	(vi) 9.44	(A0) (incorrectly rounded to 3 sf)

Markscheme	Candidates' Scripts	Marking
7.44 (7.43798...) (A1)	(i) 7.43798... is seen in the working box followed by 7; 7.4; 7.44; 7.438 etc. (correctly rounded)	(A1)
	(ii) 7.43798... is seen in the working box followed by 7.437; 7.43 etc. (incorrectly rounded)	(A1)
	(iii) 7.4	(A1)
	(iv) 7	(A0) (correct to 1 sf)
	(v) 7.5	(A0) (incorrectly rounded to 2 sf)
	(vi) 7.43	(A0) (incorrectly rounded to 3 sf)

Example: ABC is a right angled triangle with angle $\angle C = 90^\circ$, $AC = 32$ cm and $AB = 30$ cm. Find (a) the length of BC, (b) The area of triangle ABC.

Markscheme	Candidates' Scripts	Marking
(a) $BC = \sqrt{32^2 - 30^2}$ (M1) <i>Award (M1) for correct substitution in Pythagoras' formula</i> $= 11.1 (\sqrt{124}, 11.1355\dots)$ (cm) (A1)	(a) $BC = \sqrt{32^2 - 30^2}$ 11 (cm) <i>(2 sf answer only seen, but correct)</i>	(M1) (A1)
(b) $\text{Area} = \frac{1}{2} \times 30 \times 11.1355\dots$ (M1) <i>Award (M1) for correct substitution in area of triangle formula</i> $= 167(167.032\dots)$ (cm ²) (A1)(ft)	(b) case (i) $\text{Area} = \frac{1}{2} \times 30 \times 11$ $= 165$ (cm ²) case (ii) $= 165$ (cm ²) <i>(No working shown, the answer 11 is treated as a ft, so no marks awarded here)</i>	(M1) <i>(working shown)</i> (A1)(ft) (M0)(A0)(ft)

Rounding of an exact answer to 3 significant figures **should be accepted if performed correctly**.

Exact answers such as $\frac{1}{4}$ can be written as decimals to fewer than 3 significant figures if the result is still exact. Reduction of a fraction to its lowest terms is **not** essential, however where an answer simplifies to an integer this is expected. Fractions that include a decimal in the numerator and/or the denominator are acceptable for showing correct substitution, but not as a final answer.

Ratios of π and answers taking the form of square roots of integers or any rational power of an integer (e.g. $\sqrt{13}, 2^{\frac{2}{3}}, \sqrt[4]{5}$, ...) may be accepted as exact answers. All other powers (eg, of non-integers) and values of transcendental functions such as sine and cosine must be evaluated.

If the level of accuracy is specified in the question, a mark will be allocated for giving the answer to the required accuracy. In **all** such cases the final mark is not awarded if the rounding does not follow the instructions given in the question. A mark for specified accuracy can be regarded as a **(ft)** mark regardless of an immediately preceding **(M0)**.

Certain answers obtained from the GDC are worth 2 marks and working will not be seen. In these cases only one mark should be lost for accuracy.

eg, Chi-squared, correlation coefficient, mean

Markscheme	Candidates' Scripts	Marking
Chi-squared	(a) 7.7	(A2)
7.68 (7.67543...) (A2)	(b) 7.67	(A1)
	(c) 7.6	(A1)
	(d) 8	(A0)
	(e) 7	(A0)
	(e) 7.66	(A0)

Regression line

Markscheme	Candidates' Scripts	Marking
$y = 0.888x + 13.5$ (A2) ($y = 0.887686\dots x + 13.4895\dots$) If an answer is not in the form of an equation award at most (A1)(A0) .	(a) $y = 0.89x + 13$	(A2) (both accepted)
	(b) $y = 0.88x + 13$	(A1) (one rounding error)
	(c) $y = 0.88x + 14$	(A1) (rounding error repeated)
	(d) (i) $y = 0.9x + 13$ (ii) $y = 0.8x + 13$	(A1) (1 sf not accepted)
	(e) $0.88x + 14$	(A0) (two rounding errors and not an equation)

Maximum/minimum/points of intersection

Markscheme	Candidates' Scripts	Marking
(2.06, 4.49) (A1)(A1) (2.06020..., 4.49253...)	(a) (2.1, 4.5)	(A1)(A1) (both accepted)
	(b) (2.0, 4.4)	(A1) (same rounding error twice)
	(c) (2.06, 4.4)	(A1) (one rounding error)
	(d) (2, 4.4)	(A0) (1sf not accepted, one rounding error)

6 Level of accuracy in finance questions

The accuracy level required for answers will be specified in all questions involving money. This will usually be either whole units or two decimal places. The first answer not given to the specified level of accuracy will not be awarded the final **A** mark. The markscheme will give clear instructions to ensure that only one mark per paper can be lost for incorrect accuracy in a financial question.

Example: A financial question demands accuracy correct to 2 dp.

Markscheme	Candidates' Scripts	Marking
\$231.62 (231.6189) (A1)	(i) 231.6	(A0)
	(ii) 232	(A0) <i>(Correct rounding to incorrect level)</i>
	(iii) 231.61	(A0)
	(iv) 232.00	(A0) <i>(Parts (iii) and (iv) are both incorrect rounding to correct level)</i>

7 Units in answers

There will be specific questions for which the units are required and this will be indicated clearly in the markscheme. The first correct answer with no units or incorrect units will not be awarded the final **A** mark. The markscheme will give clear instructions to ensure that only one or two marks per paper can be lost for lack of units or incorrect units.

The units are considered only when the numerical answer is awarded **(A1)** under the accuracy rules given in Section 5.

Markscheme	Candidates' Scripts	Marking
(a) 37000 m ² (A1)	(a) 36000 m ²	(A0) <i>(Incorrect answer so units not considered)</i>
	(b) 3200 m ³ (A1)	(A0) <i>(Incorrect units)</i>

If no method is shown and the answer is correct but with incorrect or missing units award the C marks with a one mark penalty.

8 Graphic Display Calculators

Candidates will often obtain solutions directly from their calculators. They must use mathematical notation, not calculator notation. No method marks can be awarded for incorrect answers supported only by calculator notation. The comment "I used my GDC" cannot receive a method mark.

1. (a) $29 \times 98 \times 186$ (M1)

Note: Award (M1) for correct substitution into volume of a cuboid formula.

$530\,000 \text{ (mm}^3\text{)}$ (A1) (C2)

Note: Answer must be written to 2 sf for the final (A1) to be awarded.

[2 marks]

- (b) 5.3×10^5 (A1)(ft)(A1)(ft) (C2)

Note: Follow through from part (a).
Award (A0)(A0) for answers of the type 53×10^4 .

[2 marks]

- (c) evidence of $10 \text{ mm} = 1 \text{ cm}$ (A1)

Note: Award (A1) for dividing their volume from part (a) or part (b) by 1000.

$529 \text{ (cm}^3\text{)}$ ($528.612 \text{ (cm}^3\text{)}$) (A1)(ft) (C2)

Note: Follow through from parts (a) or (b). Accept answers written in scientific notation.

[2 marks]

Total [6 marks]

2. (a) continuous (A1) (C1)
[1 mark]

(b) $75.5(\text{km h}^{-1})$ (A1) (C1)

Note: Answer must be exact.

[1 mark]

(c) $294(\text{km h}^{-1})$ (A1) (C1)
[1 mark]

(d) (i) $\frac{300+97+80+80+71+64+21+6}{8}$ OR $\frac{719}{8}$ (M1)

Note: Award (M1) for correct sum divided by 8.

$89.9 (89.875)(\text{km h}^{-1})$ (A1) (C2)

(ii) $84.6 (84.5597\dots)(\text{km h}^{-1})$ (A1) (C1)

Note: If the response to part (d)(i) is awarded zero marks, a correct response to part (d)(ii) is awarded (C2).

[3 marks]

Total [6 marks]

3. (a) I am tired and I am happy (A1) (C1)

Note: Accept “I am happy and I am tired”.

[1 mark]

- (b) $\neg p \Rightarrow \neg q$ (A1) (C1)

Note: Accept alternate forms of logic notation.

[1 mark]

- (c) $\neg q \Rightarrow p$ (A1)(A1) (C2)

Note: Award (A1) for \Rightarrow seen between their antecedent and consequent, and (A1) for completely correct expression.

[2 marks]

- (d)

p	q	I am not happy	$q \Rightarrow p$
T	T	F	T
T	F	T	T
F	T	F	F
F	F	T	T

(A1)(A1) (C2)

Note: Award (A1) for each correct column.

[2 marks]

Total [6 marks]

4. (a) $\frac{0.5 - (-3.5)}{-3 - 9}$ OR $\frac{-3.5 - 0.5}{9 - (-3)}$ (M1)

Note: Award (M1) for correct substitution in the gradient formula.

$-0.333 \left(-\frac{1}{3}, -0.333333... \right)$ (A1) (C2)

[2 marks]

(b) $1 = -\frac{1}{3}(3) + c$ (M1)

Note: Award (M1) for substitution of their gradient from part (a) and (3, 1) into $y = mx + c$.

OR

$(y-1) = -\frac{1}{3}(x-3)$ (M1)

Note: Award (M1) for substitution of their gradient from part (a) and (3,1) into point/slope form.

$x + 3y - 6 = 0$ (A1)(ft) (C2)

Note: Follow through from part (a) but only if final values are integers. Accept any integer multiple.

[2 marks]

(c) $x + 3(0) - 6 = 0$ OR $0 = -\frac{1}{3}x + 2$ OR $(0-1) = -\frac{1}{3}(x-3)$ (M1)

Note: Award (M1) for substituting $y = 0$ into their equation from part (b).

$(6, 0)$ (A1)(ft) (C2)

Note: Coordinates must be shown. Follow through from parts (a) and (b). The final (A1)(ft) is awarded for correct coordinates derived from *their* equation, provided working is shown.

[2 marks]

Total [6 marks]

5. (a)

Bouquet size	Number of roses (n)	Frequency (f)	Cumulative frequency
small	$2 \leq n \leq 4$	15	15
medium	$5 \leq n \leq 8$	25	40
large	$9 \leq n \leq 12$	10	50

(A1)(A1)(ft) (C2)

Note: Award (A1) for 10; (A1)(ft) for the last column all correct. Follow through from *their* 10 for *their* 50 in the last column.

[2 marks]

(b) $\frac{35}{50} \left(0.7, \frac{7}{10}, 70\% \right)$

(A1)(ft)(A1)(ft) (C2)

Note: Award (A1)(ft) for their numerator being $25 + \textit{their}$ 10, and (A1)(ft) for their denominator being *their* 50. Follow through from part (a).

[2 marks]

(c) $\frac{4}{10} \left(0.4, \frac{2}{5}, 40\% \right)$

(A1)(A1)(ft) (C2)

Note: Award (A1) for a numerator of 4 and (A1)(ft) for *their* 10 as denominator. Follow through from part (a).

[2 marks]

Total [6 marks]

6. (a) $(V =) \pi(4.43)^2 \times 12.2$ **(M1)(A1)**

Note: Award **(M1)** for substitution into volume of a cylinder formula, **(A1)** for correct substitution.

752 cm^3 ($752.171\dots \text{ cm}^3$) **(A1)** **(C3)**

[3 marks]

(b) $752.171\dots = \frac{4}{3}\pi(r)^3$ **(M1)**

Note: Award **(M1)** for equating their volume to the volume of a sphere formula.

$(r =) 5.64169\dots \text{ cm}$ **(A1)(ft)**

Note: Follow through from part (a).

$(d =) 11.3 \text{ cm}$ ($11.2833\dots \text{ cm}$) **(A1)(ft)** **(C3)**

[3 marks]

Total [6 marks]

7. (a)

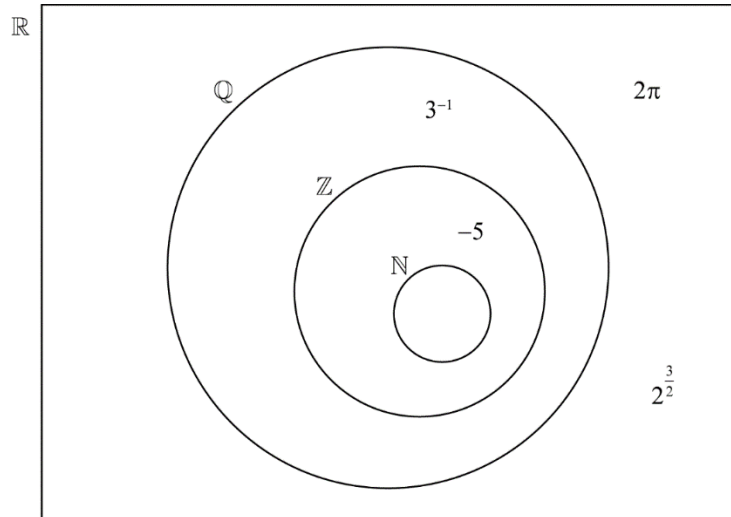

(A1)(A1)(A1)(A1) (C4)

Note: Award (A1) for each number in the correct position.

[4 marks]

(b)

Statement	True
$Z \subset Q$	✓
$N \subset Q'$	
$N \cap Z = N$	✓
$Q \cup R = Z'$	

(A1)(A1) (C2)

Note: Award (A1) for each correctly placed tick.

[2 marks]

Total [6 marks]

8. (a)

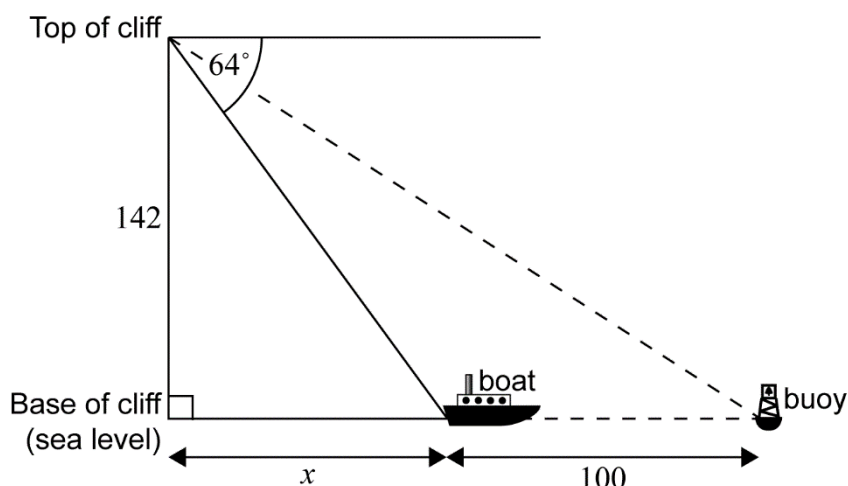

(A1) (C1)

Note: The horizontal line must be shown and the angle of depression must be labelled. Accept a numerical or descriptive label.

[1 mark]

(b) $\tan 64^\circ = \frac{142}{x}$ (or $\tan 26^\circ = \frac{x}{142}$) (M1)

Note: Award (M1) for correct substitution into trig formula.

(x =) 69.3 (m) (69.2580... (m)) (A1)(ft) (C2)

Note: Follow through from their diagram in part (a). Accept correct alternative methods.

[2 marks]

(c) $\sqrt{(69.3+100)^2 + 142^2}$ (M1)(M1)

Note: Award (M1) for adding *their* part (b) to 100, and (M1) for substituting 142 into Pythagoras.

Accept correct alternative methods such as calculation of cliff to boat distance (157.989...) using Pythagoras or trig ratios (M1), followed by substitution into cosine rule (M1).

221(m) (220.935...(m)) (A1)(ft) (C3)

Note: Follow through from part (b).

[3 marks]

Total [6 marks]

9. (a) $60 = 8.75x$ OR $\frac{60}{8.75}$ (M1)

Note: Accept a sketch of a straight line that passes through the origin with a positive gradient and 60 labelled on the vertical axis.

(x =) 6.85714... (A1)

6 (tickets) (A1) (C3)

Note: Answer must be rounded to 6 for the final (A1) to be awarded.

[3 marks]

(b) $y = 2.5x + 50$ (A1) (C1)
[1 mark]

(c) $8.75x = 2.5x + 50$ OR sketch of both equations (M1)

Note: Award (M1) for equating their two equations or for a sketch of their two lines.

8 (tickets) (A1)(ft) (C2)

Note: Follow through from part (b). Answer must be an integer.

[2 marks]

Total [6 marks]

10. (a) $(\cos A =) \frac{2.6^2 + 3.1^2 - 2.4^2}{2(2.6)(3.1)}$ (M1)(A1)

Note: Award (M1) for substituted cosine rule formula, (A1) for correct substitutions.

48.8° (48.8381...°) (A1) (C3)
[3 marks]

(b) $\frac{1}{2} \times 2.6 \times 3.1 \times \sin(48.8381...^\circ)$ (M1)(A1)(ft)

Note: Award (M1) for substituted area of a triangle formula, (A1) for correct substitution.

$3.03(\text{km}^2)$ (3.033997... (km²)) (A1)(ft) (C3)

Note: Follow through from part (a).

[3 marks]

Total [6 marks]

11. (a)

Mean and standard deviation	Graph
Mean = -2 ; standard deviation = 0.707	C
Mean = 0 ; standard deviation = 0.447	D

(A1)(A1) (C2)

Note: Award (A1) for each correct entry.

[2 marks]

(b)

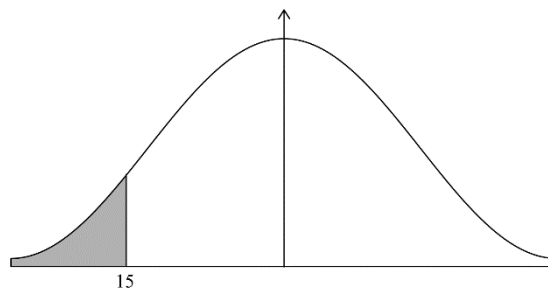

(M1)

Note: Award (M1) for sketch with 15 labelled and left tail shaded **OR** for a correct probability statement, $P(X < 15)$.

0.0766 (0.0765637..., 7.66%)

(A1) (C2)

[2 marks]

(c)

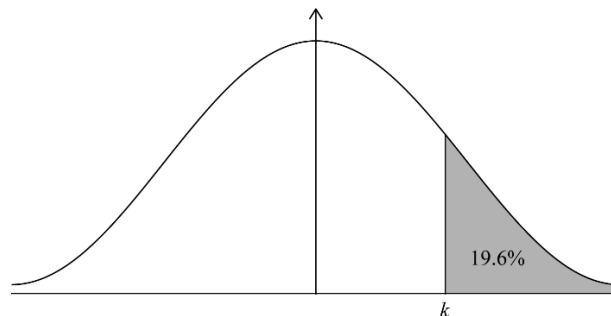

(M1)

Note: Award (M1) for a sketch showing correctly shaded region to the right of the mean with 19.6% labelled (accept shading of the complement with 80.4% labelled) **OR** for a correct probability statement, $P(X > k) = 0.196$ or $P(X \leq k) = 0.804$.

23.0(kg) (22.9959... (kg))

(A1) (C2)

[2 marks]

Total [6 marks]

12. (a) $\frac{1}{3} \times \frac{1}{3}$ OR $\left(\frac{1}{3}\right)^2$ (M1)

Note: Award (M1) for multiplying correct probabilities.

$\frac{1}{9}$ (0.111, 0.111111..., 11.1%) (A1) (C2)

[2 marks]

(b) $\left(\frac{1}{2} \times \frac{1}{3}\right) + \left(\frac{1}{6} \times \frac{1}{3}\right) + \frac{1}{3}$ (M1)(M1)

Note: Award (M1) for $\left(\frac{1}{2} \times \frac{1}{3}\right)$ and $\left(\frac{1}{6} \times \frac{1}{3}\right)$ or equivalent, and (M1) for $\frac{1}{3}$ and adding only the three correct probabilities.

OR

$1 - \left(\frac{2}{3}\right)^2$ (M1)(M1)

Note: Award (M1) for $\frac{2}{3}$ seen and (M1) for subtracting $\left(\frac{2}{3}\right)^2$ from 1. This may be shown in a tree diagram with “yellow” and “not yellow” branches.

$\frac{5}{9}$ (0.556, 0.555555..., 55.6%) (A1)(ft) (C3)

Note: Follow through marks may be awarded if their answer to part (a) is used in a correct calculation.

[3 marks]

(c) $\frac{1}{3}$ (0.333, 0.333333..., 33.3%) (A1) (C1)

[1 mark]

Total [6 marks]

13. (a) $0 = a(3)^2 + b(3) + 30$, $0 = a(5)^2 + b(5) + 30$, $-\frac{b}{2a} = 4$ (M1)

Note: Award (M1) for any **two** correct equations from above.

OR

$y = a(x-3)(x-5)$ **OR** $30 = a(0-3)(0-5)$ (M1)

Note: Award (M1) for correct substitution. Accept alternative methods.

$a = 2$, $b = -16$ (A1)(A1)

$y = 2x^2 - 16x + 30$ (A1)(ft) (C4)

Note: The final (A1)(ft) is awarded for substituting *their* seen values of a and b into the required form of the equation (with a constant of 30).

[4 marks]

(b) $x = 4$
(A1)(A1) (C2)

Note: Award (A1) for $x =$ constant, (A1) for the constant being 4.

[2 marks]

Total [6 marks]

14. (a) $1100 = PV \times \left(1 + \frac{3.1}{(100)(12)} \right)^{(6)(12)}$ **(M1)(A1)**

Note: Award **(M1)** for substitution into compound interest formula, **(A1)** for correct substitution.

OR

$$N = 6$$

$$I\% = 3.1$$

$$FV = \pm 1100$$

$$P/Y = 1$$

$$C/Y = 12$$

(M1)(A1)

Note: Award **(A1)** for $C/Y = 12$ seen, **(M1)** for other correct entries.

OR

$$N = 72$$

$$I\% = 3.1$$

$$FV = \pm 1100$$

$$P/Y = 12$$

$$C/Y = 12$$

(M1)(A1)

Note: Award **(A1)** for $C/Y = 12$ seen, **(M1)** for other correct entries.

$$(\$) 913.52$$

(A1)

(C3)

[3 marks]

Question 14 continued

$$(b) \quad 350 = 1100 \times \left(1 + \frac{r}{(100)(1)} \right)^{(4)(1)} \quad \text{OR} \quad 350 = 1100 \times (1+r)^4 \quad (M1)(A1)$$

Note: Award **(M1)** for a substituted compound interest formula, in either form, equated to 350, **(A1)** for correct substitution.

OR

$$350 = 1100 \times r^4 \quad (M1)(A1)$$

Note: Award **(M1)** for a substituted term of a geometric sequence formula equated to 350, **(A1)** for correct substitution.

OR

$$\begin{aligned} N &= 4 \\ FV &= \pm 350 \\ PV &= \mp 1100 \\ P/Y &= 1 \\ C/Y &= 1 \end{aligned}$$

(M1)(A1)

Note: Award **(A1)** for $C/Y = 1$ seen, **(M1)** for other correct entries. FV and PV must have opposite signs.

$$24.9\% \quad (24.8950\dots\%, 0.249)$$

(A1) (C3)

[3 marks]

Total [6 marks]

15. (a) $A = 2\pi r(12 - r)$ OR $A = 24\pi r - 2\pi r^2$ (A1)(M1) (C2)

Note: Award (A1) for $r + h = 12$ or $h = 12 - r$ seen. Award (M1) for correctly substituting into curved surface area of a cylinder. Accept $A = 2\pi r(12 - r)$ OR $A = 24\pi r - 2\pi r^2$.

[2 marks]

- (b) $24\pi - 4\pi r$ (A1)(ft)(A1)(ft) (C2)

Note: Award (A1)(ft) for 24π and (A1)(ft) for $-4\pi r$. Follow through from part (a). Award at most (A1)(ft)(A0) if additional terms are seen.

[2 marks]

- (c) $24\pi - 4\pi r = 0$ (M1)

Note: Award (M1) for setting *their* part (b) equal to zero.

- 6 (cm) (A1)(ft) (C2)

Note: Follow through from part (b).

[2 marks]

Total [6 marks]