



**Physics**  
**Standard level**  
**Paper 2**

Friday 8 May 2015 (morning)

Candidate session number

--	--	--	--	--	--	--	--	--	--

1 hour 15 minutes

**Instructions to candidates**

- Write your session number in the boxes above.
- Do not open this examination paper until instructed to do so.
- Section A: answer all questions.
- Section B: answer one question.
- Write your answers in the boxes provided.
- A calculator is required for this paper.
- A clean copy of the **physics data booklet** is required for this paper.
- The maximum mark for this examination paper is **[50 marks]**.



Please **do not** write on this page.

Answers written on this page will not  
be marked.



**Section A**

Answer **all** questions. Write your answers in the boxes provided.

1. This question is about the flow of liquids.

A student carries out an experiment to investigate how the rate of flow  $R$  of water through a narrow tube varies with the pressure difference across the tube. The pressure difference is proportional to the height  $h$  shown in the diagram. The student measures  $h$  in cm with a metre ruler.  $R$  is obtained by measuring the volume of water collected in a measuring cylinder in a time of 100 s.

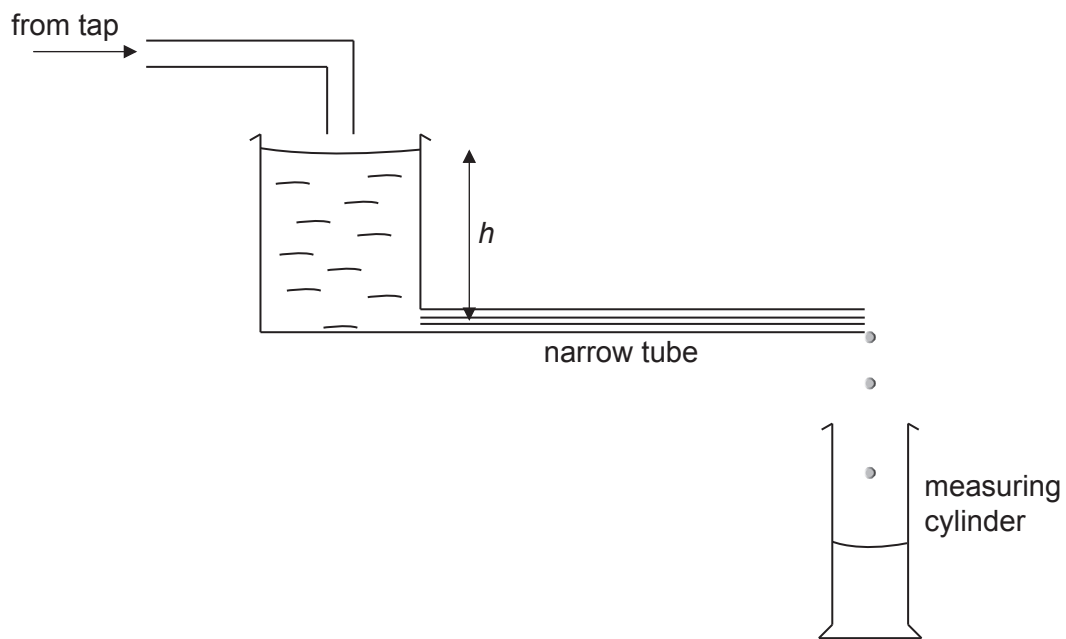

(This question continues on the following page)



**(Question 1 continued)**

- (a) The student enters the data on a spreadsheet and produces the graph and trend line shown below.

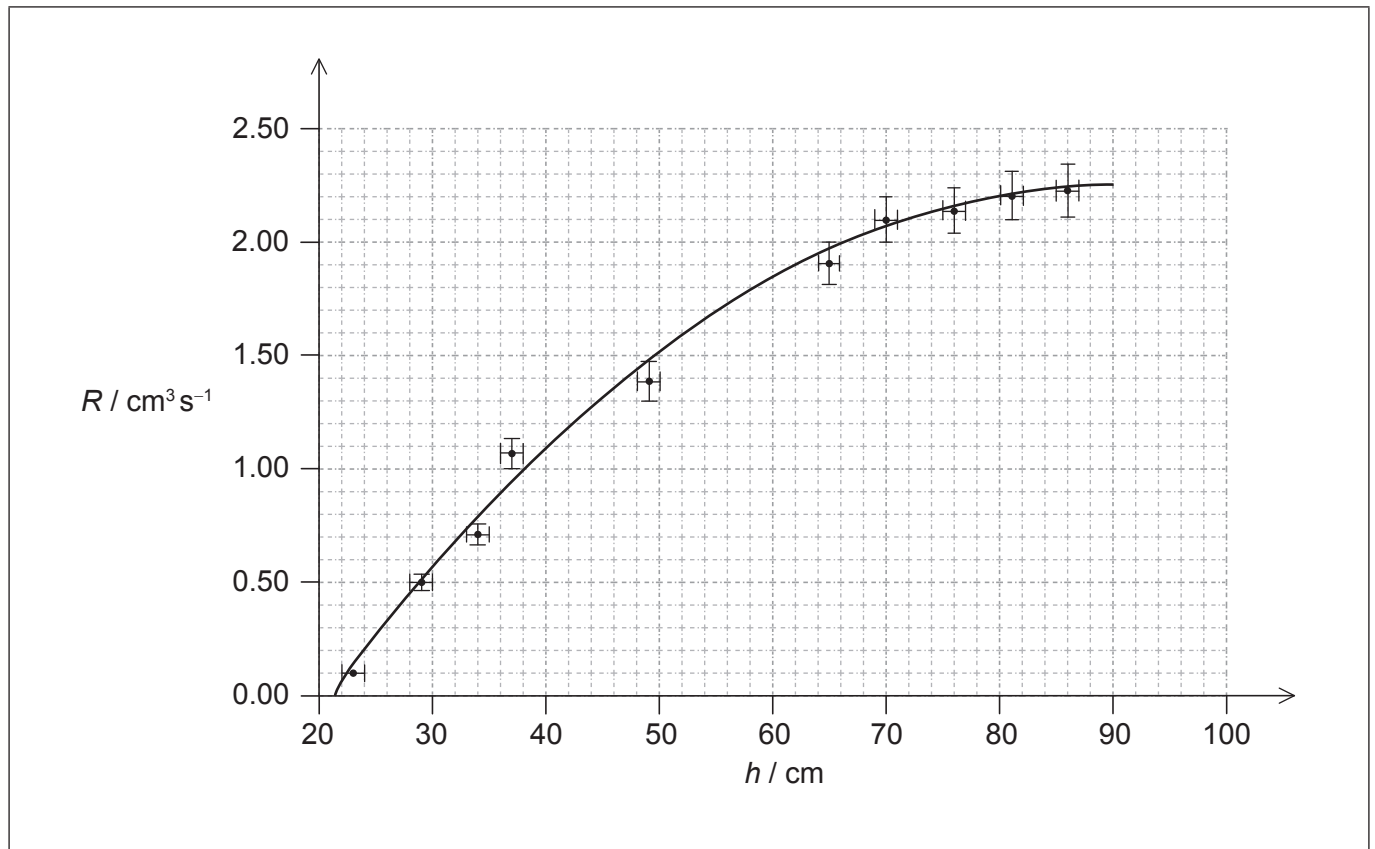

The data point for  $h = 57 \text{ cm}$ ,  $R = 1.70 \text{ cm}^3 \text{ s}^{-1}$  has not been shown on the graph. The student estimates the uncertainties in all values of  $h$  to be  $\pm 1 \text{ cm}$  and the uncertainties in the values of  $R$  to be  $\pm 5\%$ .

- (i) On the graph, draw the missing data point. [1]
- (ii) On the graph, draw the vertical error bar for this data point. [1]
- (iii) Comment on why the trend line is not a perfect match for the data. [1]

.....

.....

(This question continues on the following page)



(Question 1 continued)

(iv) Explain why the student's estimate of a 5% uncertainty in all values for  $R$  is unlikely to be correct.

[2]

.....

.....

.....

.....

(b) The student estimates that the uncertainty in timing 100 s is  $\pm 1$  s. Using the data on the graph, deduce the absolute uncertainty in the volume of water collected when  $R = 2.1 \text{ cm}^3 \text{ s}^{-1}$ .

[4]

.....

.....

.....

.....

.....

.....

.....

.....



2. This question is about the forces on a skier.

A skier is pulled up a hill by a rope at a steady velocity. The hill makes an angle of  $12^\circ$  with the horizontal. The mass of the skier and skis is 73 kg. The diagram below shows three of the forces acting on the skier.

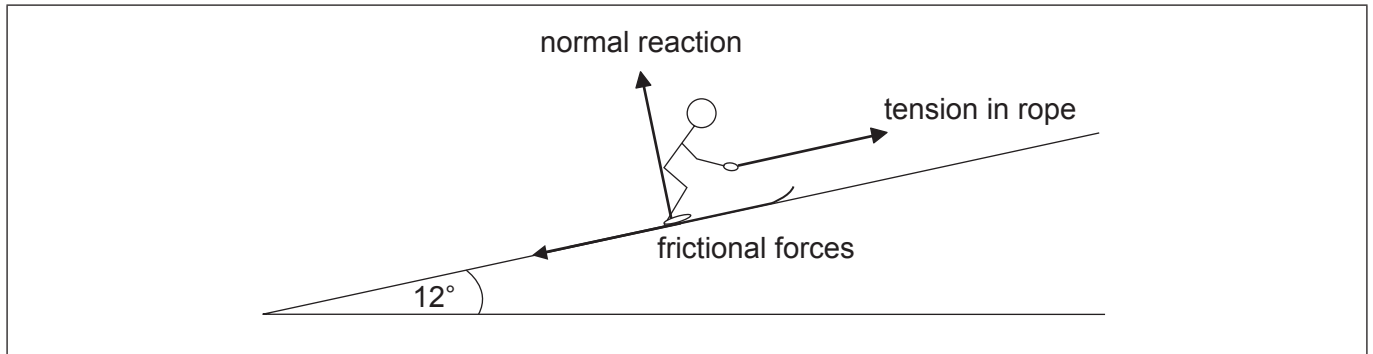

- (a) On the diagram, draw and label **one** other force acting on the skier. [1]
- (b) Calculate the magnitude of the normal reaction acting on the skier. [2]

.....

.....

.....

.....

- (c) The total frictional force acting is 65 N. Determine the tension in the rope. [2]

.....

.....

.....

.....

- (d) Explain, using Newton's first law of motion, why the resultant force on the skier must be zero. [2]

.....

.....

.....

.....

3. This question is about thermal properties of matter.

- (a) Explain, in terms of the energy of its molecules, why the temperature of a pure substance does not change during melting. [3]

.....

.....

.....

.....

(b) Three ice cubes at a temperature of 0 °C are dropped into a container of water at a temperature of 22 °C. The mass of each ice cube is 25 g and the mass of the water is 330 g. The ice melts, so that the temperature of the water decreases. The thermal capacity of the container is negligible.

- (i) Define *thermal capacity*. [1]

.....

.....

- (ii) State the SI unit of thermal capacity. [1]

.....

(iii) The following data are available.

Specific latent heat of fusion of ice =  $3.3 \times 10^5 \text{ J kg}^{-1}$   
Specific heat capacity of water =  $4.2 \times 10^3 \text{ J kg}^{-1} \text{ K}^{-1}$

Calculate the final temperature of the water when all of the ice has melted. Assume that no thermal energy is exchanged between the water and the surroundings. [4]

.....

.....

.....

.....

.....

.....



Please **do not** write on this page.

Answers written on this page will not  
be marked.





### Section B

This section consists of three questions: 4, 5 and 6. Answer **one** question. Write your answers in the boxes provided.

4. This question is about energy sources.

A small island is situated in the Arctic. The islanders require an electricity supply but have no fossil fuels on the island. It is suggested that wind generators should be used in combination with power stations using either oil or nuclear fuel.

(a) Suggest the conditions that would make use of wind generators in combination with either oil or nuclear fuel suitable for the islanders. [3]

.....

.....

.....

.....

.....

.....

(b) Conventional horizontal-axis wind generators have blades of length 4.7 m. The average wind speed on the island is  $7.0 \text{ m s}^{-1}$  and the average air density is  $1.29 \text{ kg m}^{-3}$ .

(i) Deduce the total energy, in GJ, generated by the wind generators in one year. [3]

.....

.....

.....

.....

(ii) Explain why less energy can actually be generated by the wind generators than the value you deduced in (b)(i). [2]

.....

.....

.....

.....

(This question continues on the following page)



(Question 4 continued)

- (c) The energy flow diagram (Sankey diagram) below is for an oil-fired power station that the islanders might use.

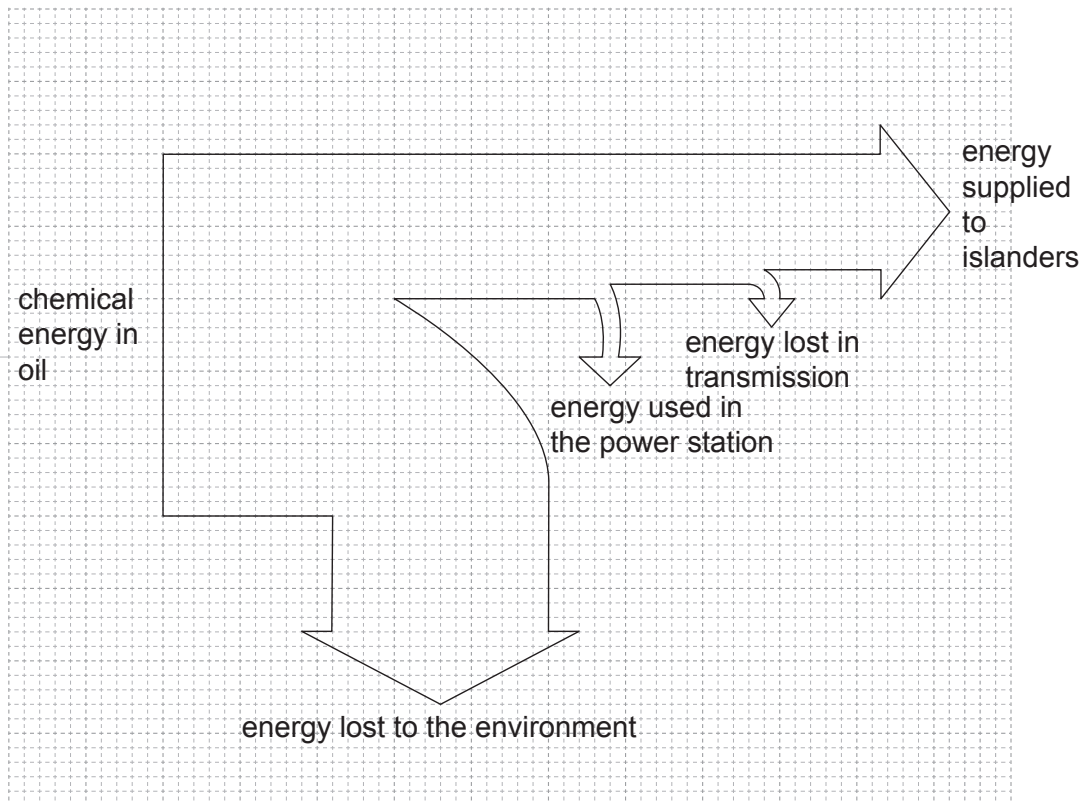

- (i) Determine the efficiency of the power station. [2]

.....  
.....  
.....  
.....

- (ii) Explain why energy is wasted in the power station. [1]

.....  
.....

(This question continues on the following page)



**(Question 4 continued)**

- (iii) The Sankey diagram in (c) indicates that some energy is lost in transmission. Explain how this loss occurs. [1]

.....  
.....

- (d) The emissions from the oil-fired power station in (c) are likely to increase global warming by the enhanced greenhouse effect.

- (i) State what is meant by the enhanced greenhouse effect. [2]

.....  
.....  
.....  
.....

- (ii) Outline the mechanism by which greenhouse gases contribute to global warming. [3]

.....  
.....  
.....  
.....  
.....  
.....

- (e) Any nuclear fuel available to the islanders must be enriched before it can be used. Outline why fuel enrichment is needed. [2]

.....  
.....  
.....  
.....

**(This question continues on the following page)**



**(Question 4 continued)**

- (f) The nuclear equation below shows one of the possible fission reactions in a nuclear reactor.

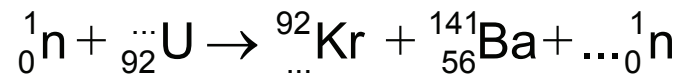

Identify the missing numbers in the equation.

[3]

- (g) A nuclear reactor requires both control rods and a moderator to operate. Outline, with reference to neutrons, **one** similarity and **two** differences in the function of each of these components.

[3]

.....  
.....  
.....  
.....



5. This question is in **two** parts. **Part 1** is about a thermistor circuit. **Part 2** is about vibrations and waves.

**Part 1** Thermistor circuit

The circuit shows a negative temperature coefficient (NTC) thermistor X and a  $100\text{ k}\Omega$  fixed resistor R connected across a battery.

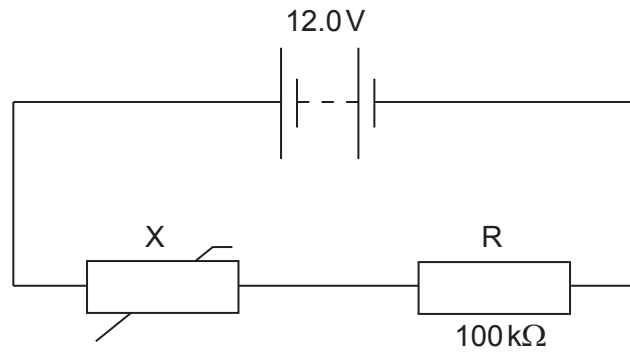

The battery has an electromotive force (emf) of  $12.0\text{V}$  and negligible internal resistance.

- (a) (i) Define *electromotive force (emf)*. [1]

.....  
 .....

- (ii) State how the emf of the battery can be measured. [1]

.....  
 .....

(This question continues on the following page)



**(Question 5, part 1 continued)**

- (b) The graph below shows the variation with temperature  $T$  of the resistance  $R_x$  of the thermistor.

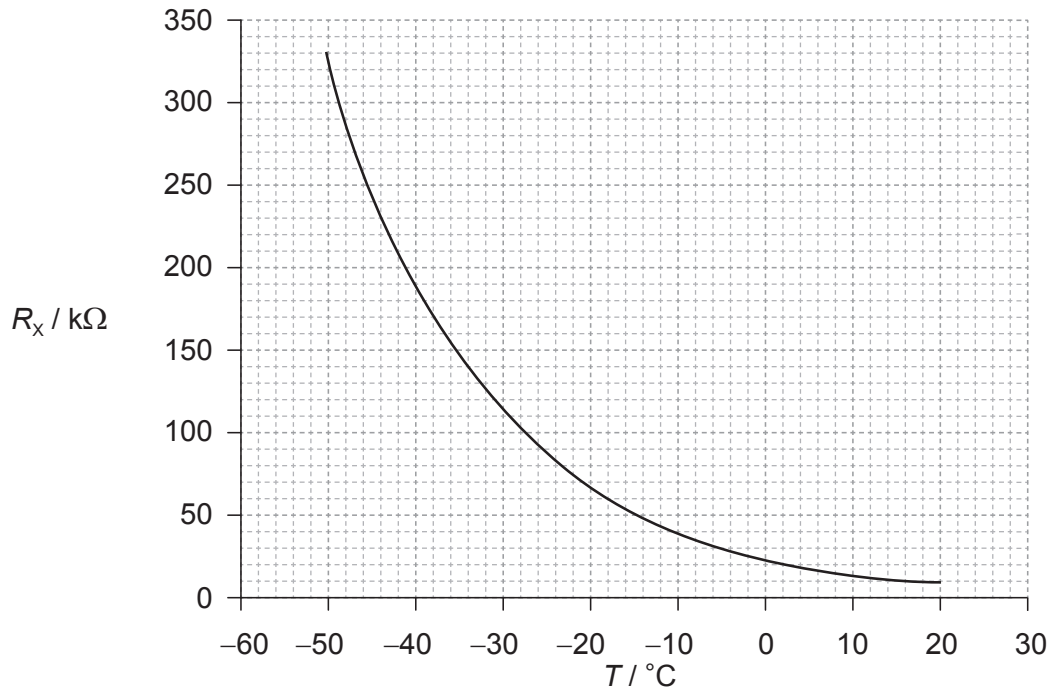

- (i) Determine the temperature of X when the potential difference across R is 4.5V. [4]

.....

.....

.....

.....

.....

.....

.....

.....

- (ii) State the range of temperatures for which the change in the resistance of the thermistor is most sensitive to changes in temperature. [1]

.....

.....

(This question continues on the following page)



**(Question 5, part 1 continued)**

(iii) State and explain the effect of a decrease in temperature on the ratio

$$\frac{\text{voltage across X}}{\text{voltage across R}}$$

[2]

.....

.....

.....

.....

**(This question continues on the following page)**



(Question 5 continued)

Part 2 Vibrations and waves

The cone and dust cap D of a loudspeaker L vibrates with a frequency of 1.25 kHz with simple harmonic motion (SHM).

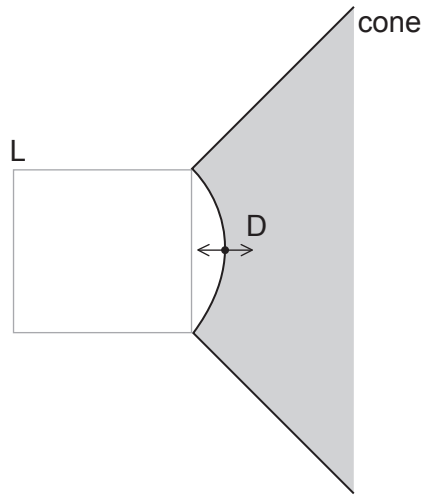

(c) Define *simple harmonic motion (SHM)*.

[2]

.....  
.....  
.....  
.....

(d) D has mass  $6.5 \times 10^{-3}$  kg and vibrates with amplitude 0.85 mm.

(i) Calculate the maximum acceleration of D.

[2]

.....  
.....  
.....  
.....

(This question continues on the following page)





(Question 5, part 2 continued)

(ii) Determine the total energy of D. [2]

.....  
.....  
.....  
.....

(e) The sound waves from the loudspeaker travel in air with speed  $330 \text{ m s}^{-1}$ .

(i) Calculate the wavelength of the sound waves. [1]

.....  
.....

(ii) Describe the characteristics of sound waves in air. [3]

.....  
.....  
.....  
.....  
.....  
.....

(This question continues on the following page)



## (Question 5, part 2 continued)

- (f) A second loudspeaker S emits the same frequency as L but vibrates out of phase with L. The graph below shows the variation with time  $t$  of the displacement  $x$  of the waves emitted by S and L.

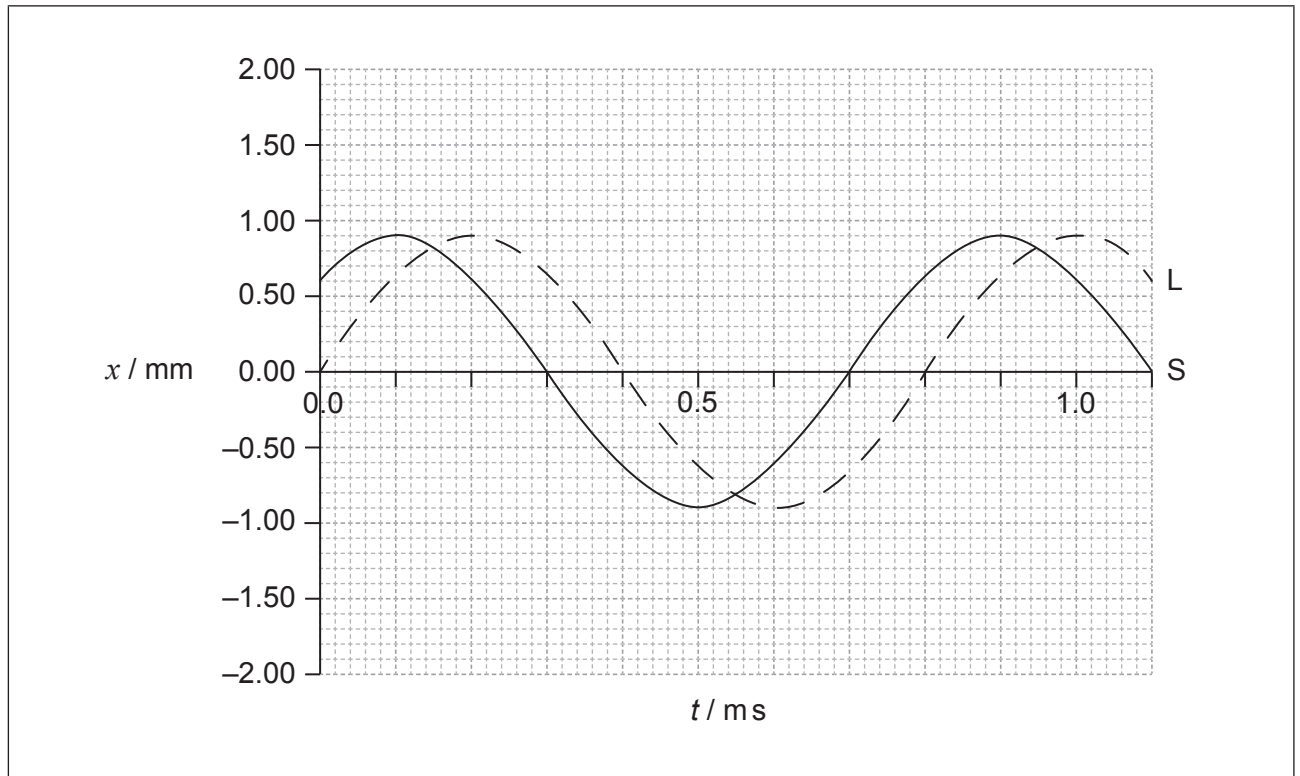

- (i) Deduce the relationship between the phase of L and the phase of S. [3]

.....

.....

.....

.....

- (ii) On the graph, sketch the variation with  $t$  of  $x$  for the wave formed by the superposition of the two waves. [3]



Please **do not** write on this page.

Answers written on this page will not  
be marked.



24EP19

Turn over

6. This question is in **two** parts. **Part 1** is about kinematics and gravitation. **Part 2** is about radioactivity.

**Part 1** Kinematics and gravitation

A ball is released near the surface of the Moon at time  $t = 0$ . The point of release is on a straight line between the centre of Earth and the centre of the Moon. The graph below shows the variation with time  $t$  of the displacement  $s$  of the ball from the point of release.

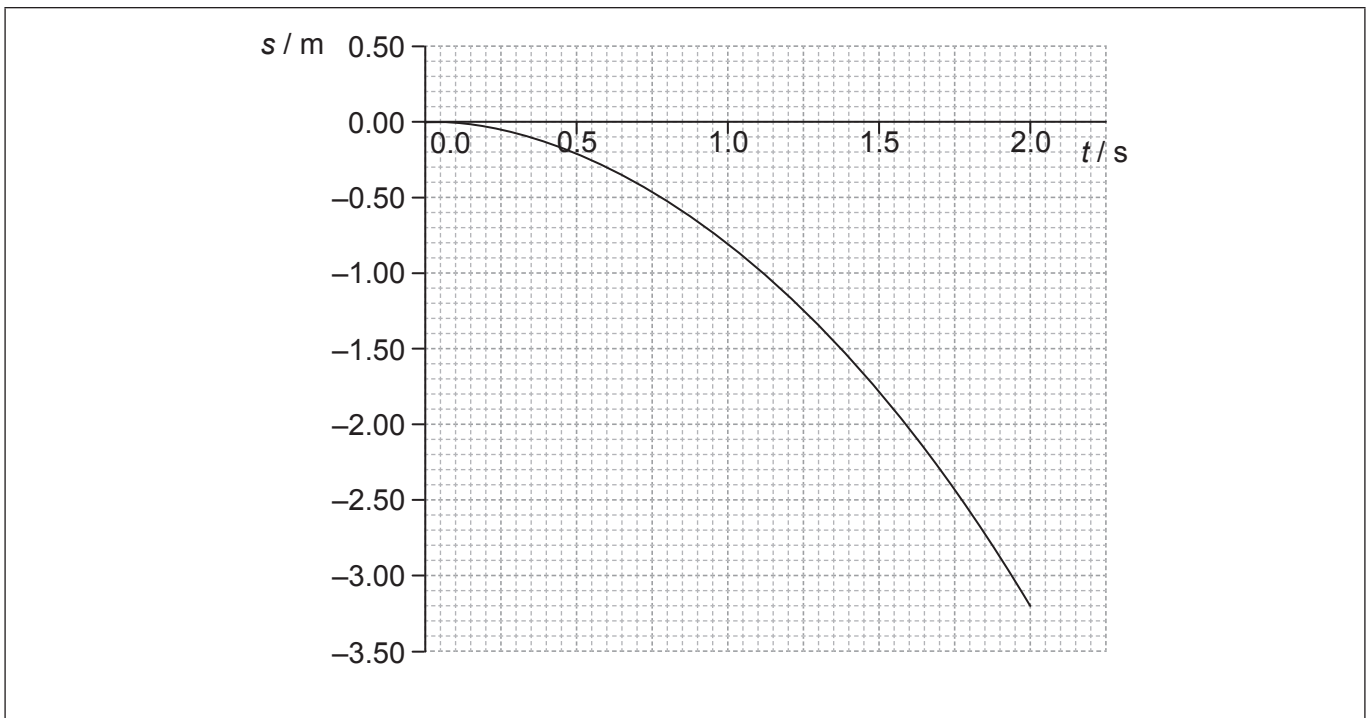

- (a) State the significance of the negative values of  $s$ . [1]

.....  
 .....

- (b) Use the graph to

- (i) estimate the velocity of the ball at  $t = 0.80$  s. [3]

.....  
 .....

(This question continues on the following page)



(Question 6, part 1 continued)

- (ii) calculate a value for the acceleration of free fall close to the surface of the Moon. [3]

.....

.....

.....

.....

- (c) The following data are available.

Mass of the ball	= 0.20 kg
Mean radius of the Moon	= $1.74 \times 10^6$ m
Mean orbital radius of the Moon about the centre of Earth	= $3.84 \times 10^8$ m
Mass of Earth	= $5.97 \times 10^{24}$ kg

- Show that Earth has no significant effect on the acceleration of the ball. [4]

.....

.....

.....

.....

.....

.....

- (d) Calculate the speed of an identical ball when it falls 3.0 m from rest close to the surface of Earth. Ignore air resistance. [1]

.....

.....

- (e) Sketch, on the graph, the variation with time  $t$  of the displacement  $s$  from the point of release of the ball when the ball is dropped close to the surface of Earth. (For this sketch take the direction towards the Earth as being negative.) [3]

(This question continues on the following page)



**(Question 6 continued)****Part 2 Radioactivity**

Two isotopes of calcium are calcium-40 ( ${}^{40}_{20}\text{Ca}$ ) and calcium-47 ( ${}^{47}_{20}\text{Ca}$ ). Calcium-40 is stable and calcium-47 is radioactive with a half-life of 4.5 days.

- (f) Explain, in terms of the number of nucleons and the forces between them, why calcium-40 is stable and calcium-47 is radioactive.

[3]

.....

.....

.....

.....

- (g) Calculate the percentage of a sample of calcium-47 that decays in 27 days.

[3]

.....

.....

.....

.....

**(This question continues on the following page)**



**(Question 6, part 2 continued)**

- (h) The nuclear equation for the decay of calcium-47 into scandium-47 ( ${}^{47}_{21}\text{Sc}$ ) is given by

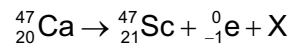

- (i) Identify X. [1]

.....

- (ii) The following data are available.

Mass of calcium-47 nucleus = 46.95455 u

Mass of scandium-47 nucleus = 46.95241 u

- Using the data, determine the maximum kinetic energy, in MeV, of the products in the decay of calcium-47. [2]

.....  
 .....  
 .....  
 .....

- (iii) State why the kinetic energy will be less than your value in (h)(ii). [1]

.....  
 .....



Please **do not** write on this page.

Answers written on this page  
will not be marked.

