



Oxford Cambridge and RSA

AS Level in Design and Technology: Product Design

H006/01 Principles of Product Design

Monday 14 May 2018 – Afternoon

Time allowed: 1 hour 45 minutes



You may use:

- a scientific calculator
- a ruler
- pencils/pens
- geometrical instruments



First name										
Last name										
Centre number						Candidate number				

INSTRUCTIONS

- Use black ink. HB pencil may be used for graphs and diagrams only.
- Complete the boxes above with your name, centre number and candidate number.
- Answer **all** the questions.
- Write your answer to each question in the space provided. If additional space is required, use the lined page(s) at the end of this booklet. The question number(s) must be clearly shown.
- Where appropriate, your answers should be supported with working. Marks may be given for a correct method even if the answer is incorrect.
- Do **not** write in the barcodes.

INFORMATION

- The total mark for this paper is **90**.
- The marks for each question are shown in brackets [].
- Quality of extended responses will be assessed in the questions marked with an asterisk (*).
- This document consists of **24** pages.

Answer **all** the questions.

- 1 **Fig. 1.1** shows a portable, battery-powered Bluetooth speaker that includes a carabiner clip. Bluetooth technology enables devices to be wirelessly linked over a short distance.

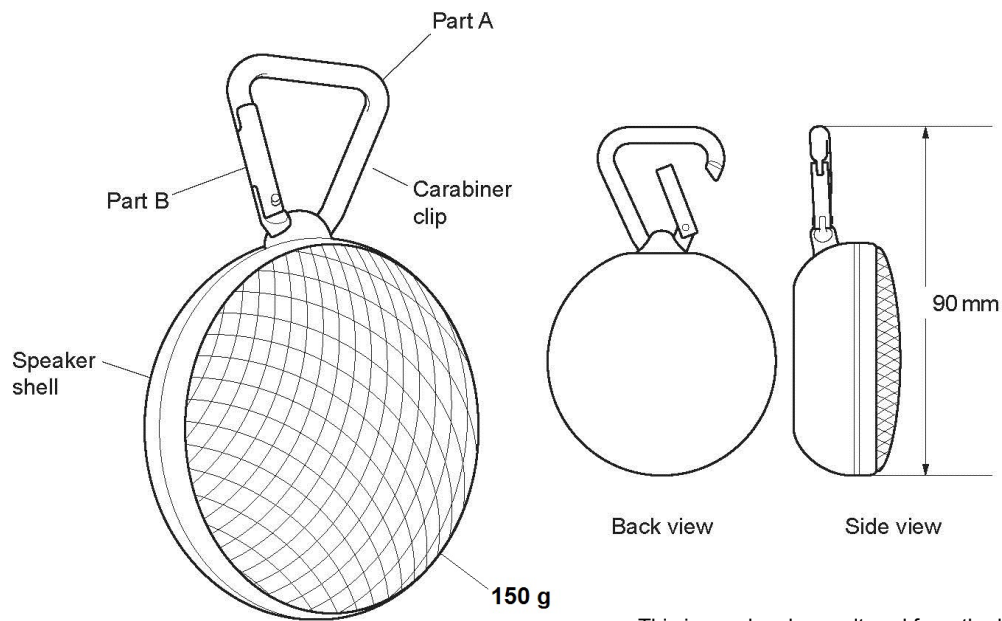

This image has been altered from the live examination version due to third party copyright restrictions.

Fig. 1.1
(not to scale)

- (a) Analyse the product in **Fig. 1.1** to identify **three** features that make the speaker portable.

1

.....

2

.....

3

.....

[3]

- (b) The carabiner clip is manufactured from an alloy.

Explain **one** reason why an alloy has been used to manufacture the carabiner clip.

.....

.....

.....

.....

[2]

(c) The alloy is extruded into a rod which is used to form part A and part B of the carabiner clip as shown in **Fig. 1.1**. The rod for part A is then heated and bent around a former to produce the curved shape of the carabiner clip.

(i) Give **two** reasons why extrusion has been used to form the alloy rod. Justify your response.

1

.....

.....

.....

2

.....

.....

.....

[4]

(ii) Explain **one** reason why casting is **not** a suitable method for the manufacturing of part A, the curved component.

.....

.....

.....

.....

[2]

(d) The main components of the carabiner clip, parts A and B, have been through a finishing process.

(i) State **one** suitable process for finishing the carabiner clip.

..... [1]

(ii) Give **two** advantages of using the finishing process identified in **part (i)**.

1

.....

2

.....

[2]

5

- 2 **Fig. 2.1** shows a fidget spinner. Fidget spinners are a popular handheld toy. They can be held in different ways and spin using ball bearings.



Fig. 2.1

Fig. 2.2 shows a CAD drawing of a fidget spinner.

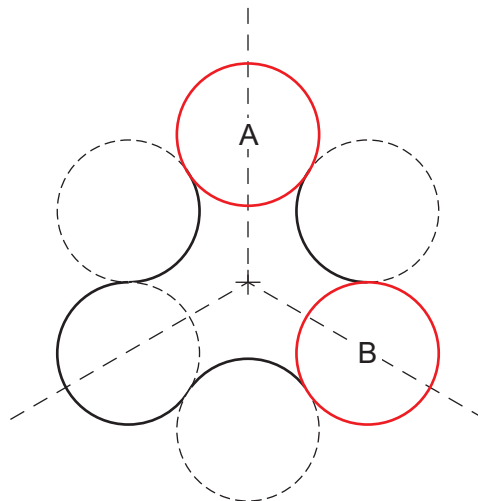

Fig. 2.2

- (a) When mapping out the spinner the designer has to calculate the angle of rotation to transform circle A to circle B. Calculate the angle of rotation.

Angle of rotation°

[1]

Fig. 2.3 shows a working drawing of the fidget spinner.

The radius of each circle is 15 mm.

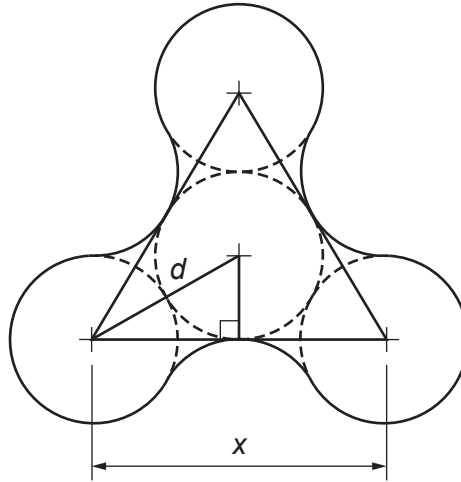

Fig. 2.3
(not to scale)

(b) Use the information in Fig. 2.3 to answer the following questions.

(i) Show how $d = 30$ mm.

..... [1]

(ii) Calculate the length x . Show your working.

$x = \dots\dots\dots$ mm

[3]

7

- (iii) The packaging for the fidget spinner is to be a square-based cardboard box. Using the information in **Fig. 2.3** and your answer to **part (ii)**, calculate the minimum internal length of the square base of the packaging.

Minimum internal length of packaging	mm
--	----

[1]

- (c) The fidget spinner has a hidden ball bearing under the cover in the centre so that the toy can spin. The fidget spinner has three ball bearings as weights at the end of each arm to help the toy spin.

Fig. 2.4 shows a diagram of a fidget spinner.

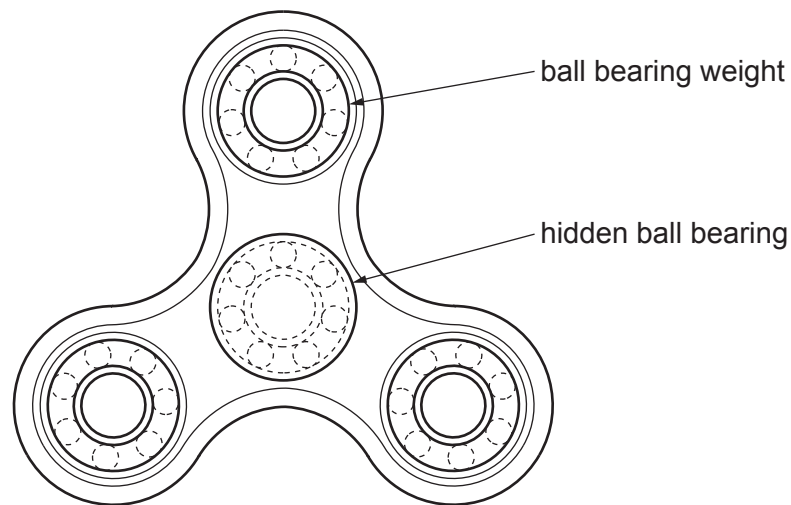

Fig. 2.4

When developing the device it is tested with two different types of ball bearings. The spin times before the fidget spinner comes to a stop are recorded in Fig. 2.5.

	Spin time in seconds (s)								
Type A	62	67	72	75	63	71	67	73	71
Type B	85	92	87	85	93	94	81	83	89

Fig. 2.5

Using the data from Fig. 2.5, calculate the mean spin time for both types of ball bearing.

	Type A s
	Type B s

[2]

- (d) Four ball bearings are needed for each spinner. The ball bearings are sold in boxes of 100. Each box costs £19.90. There is a 5% discount when more than five boxes are ordered. The initial order is for ball bearings to make 140 spinners.

Calculate how many boxes are needed for the initial order and the total cost of the order. Show your working.

	Number of boxes
	Total cost of the order £

[3]

- 3 Fig. 3.1 shows two views of a handle for a cupboard door made from hardwood. Fig. 3.2 shows the threaded metal insert from Fig. 3.1.

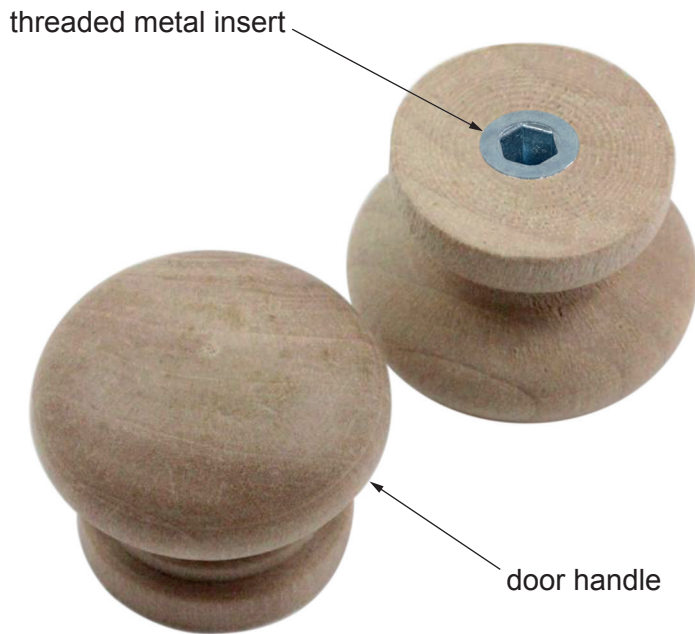

Fig. 3.1

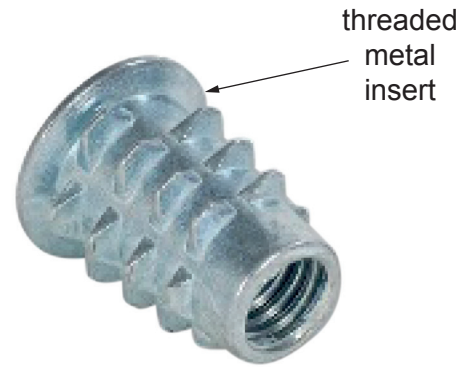

Fig. 3.2

- Fig. 3.3 shows the front, plan and sectional side views of the door handle and threaded metal insert.

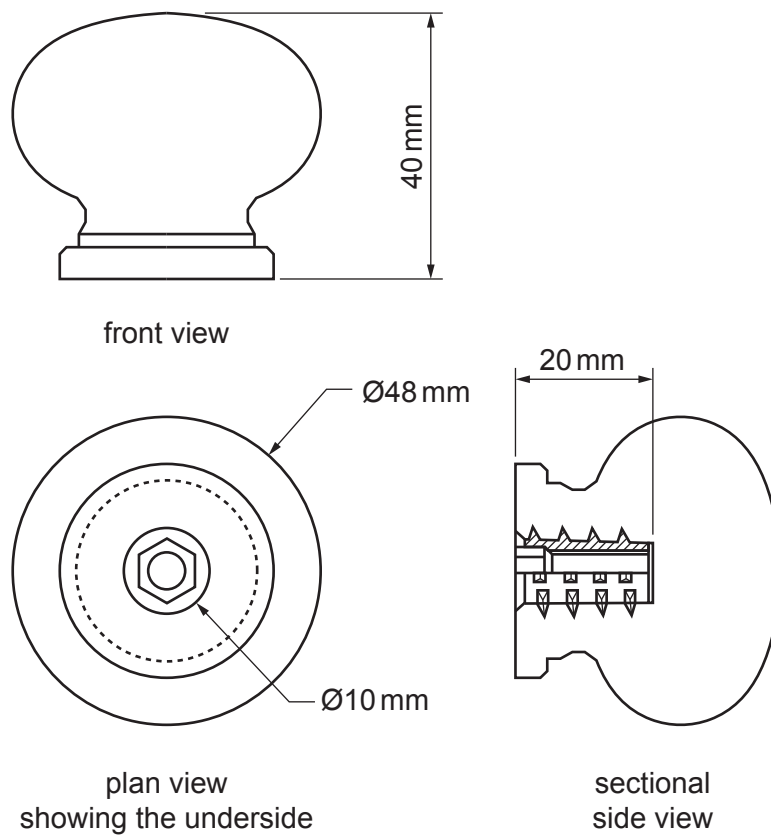



Fig. 3.3
(not to scale)

- (a) Use annotated sketches and/or notes to show how the threaded metal insert shown in **Fig. 3.2** would be manufactured as a batch of 7 000.

In your response you should include details of the manufacturing processes that would be used. Identify any relevant material, equipment and machinery.



[8]

12

- (b) The door handle would be packaged in a transparent, thermoplastic shell with a cardboard backing. **Fig. 3.4** shows the shell packaging.

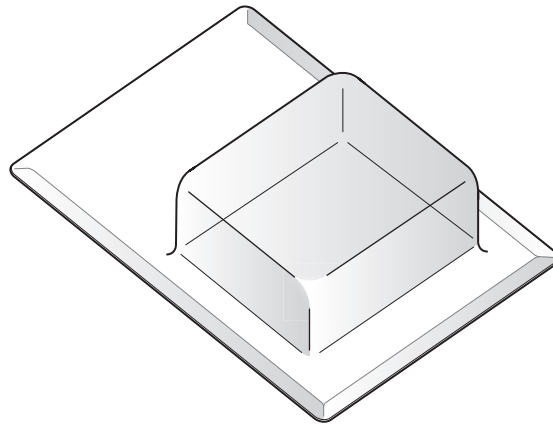
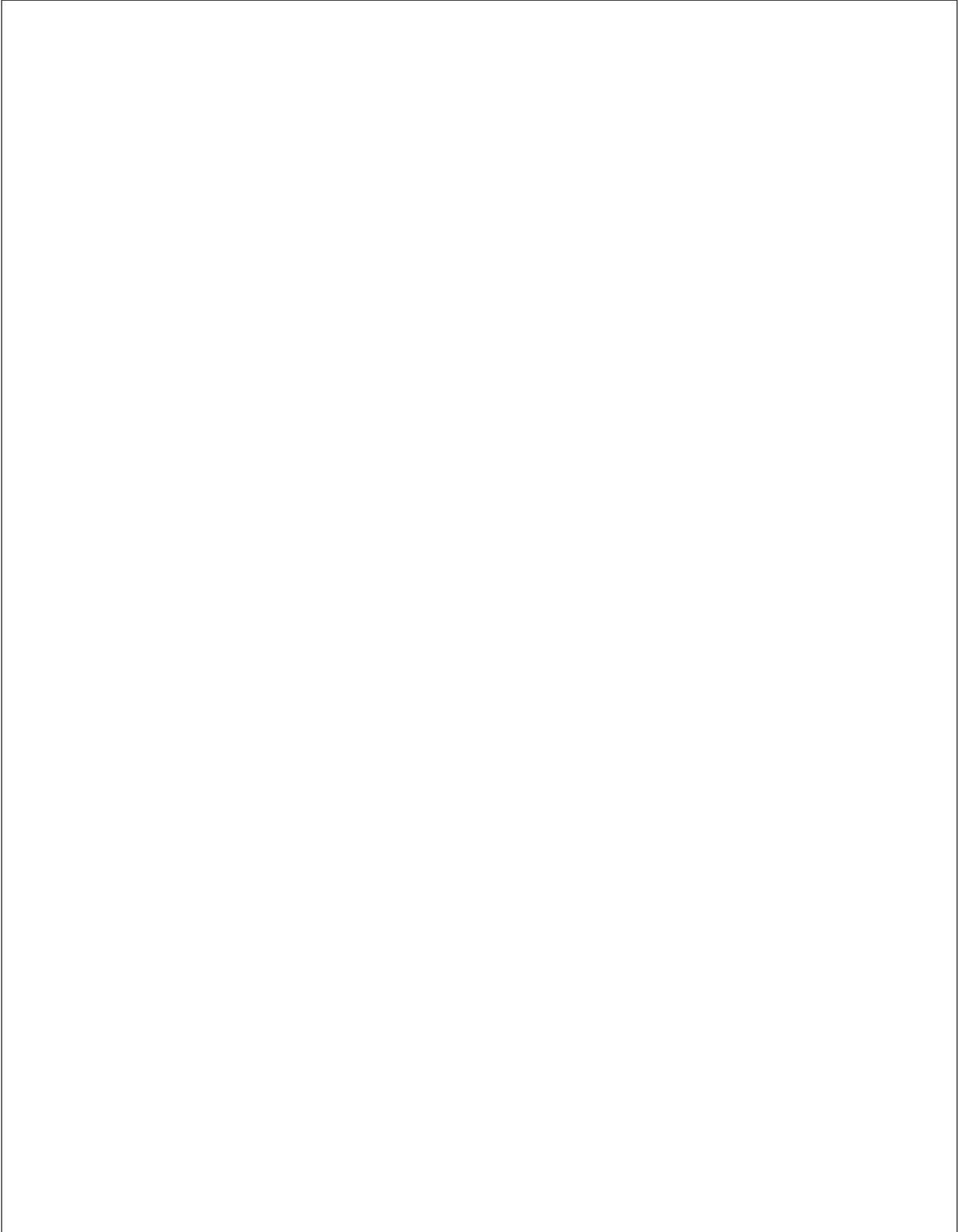

Fig. 3.4

13

Use annotated sketches and/or notes to show how the shell packaging in **Fig. 3.4** would be manufactured in a school or college workshop.

In your response you should include details of the manufacturing process that would be used. Identify any relevant material, equipment and machinery.



(c) Risk assessments should be carried out to assess the potential hazards and to specify control measures when manufacturing the shell packaging in **Fig. 3.4**.

(i) Identify **two** potential hazards during the manufacture of the packaging. Specify a control measure for each hazard identified.

1

.....

.....

.....

2

.....

.....

.....

[4]

(ii) Explain **one** reason why it is important to carry out these risk assessments.

.....

.....

.....

.....

[2]

15
BLANK PAGE

PLEASE DO NOT WRITE ON THIS PAGE

4 Fig. 4.1 shows a child's scooter.

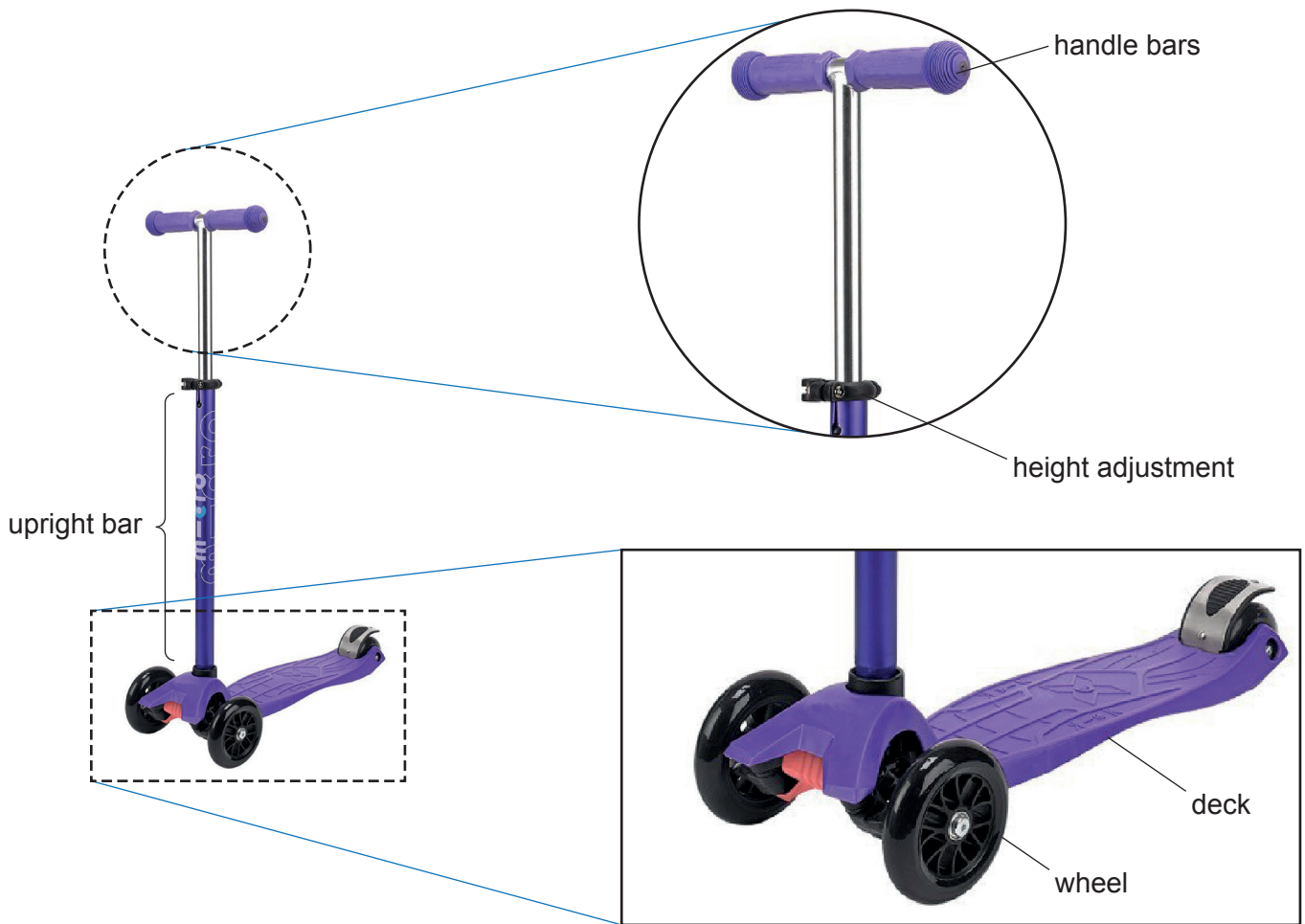

Fig. 4.1

(a) The height of the handle bars shown in Fig. 4.1 can be adjusted. State **two** benefits to the user of being able to adjust the height. Justify your response.

1

.....

.....

.....

.....

2

.....

.....

.....

.....

[4]

- (d) The upright bar of the scooter, labelled in **Fig. 4.1**, can be personalised with a padded sleeve. The padded sleeve is a hollow cylinder which slides over the upright bar and covers the whole area, as shown in **Fig. 4.3**.



Fig. 4.3

- (i) Name **one** suitable material for the surface of the padded sleeve.

..... [1]

- (ii) Give **one** reason why this material would be used.

.....
 [1]

- (iii) A pattern is printed onto the surface of the padded sleeve. Calculate the external surface area of the padded sleeve which will need to be printed.

The diameter of the upright bar in **Fig. 4.3** is 30 mm.
 The padded sleeve material is 2 mm thick.
 The height of the padded sleeve is 480 mm.

External surface area mm²

[3]

ADDITIONAL ANSWER SPACE

If additional space is required, you should use the following lined page(s). The question number(s) must be clearly shown in the margin(s).

A large area of lined paper for writing. It consists of a vertical solid line on the left side, creating a margin. To the right of this line, there are numerous horizontal dotted lines spaced evenly down the page, providing a guide for writing.

A blank sheet of lined paper. On the left side, there is a solid vertical line that serves as a margin. The rest of the page is filled with horizontal dotted lines, providing a guide for writing. The lines are evenly spaced and extend across the width of the page.

