

AS Level in Design and Technology: Design Engineering (H004/01) Principles of Design Engineering Sample Question Paper

Version 3.2

Date – Morning/Afternoon

Time allowed: 1 hour 45 minutes

You may use:

- a scientific calculator
- a ruler
- geometrical instruments
- pencils/pens



First name

Last name

Centre
numberCandidate
number

INSTRUCTIONS

- Use black ink. HB pencil may be used for graphs and diagrams only.
- Complete the boxes above with your name, centre number and candidate number.
- Answer **all** the questions.
- Write your answer to each question in the space provided. Additional paper may be used if necessary, but you must clearly show your candidate number, centre number and question number(s).
- Where appropriate, your answers should be supported with working. Marks may be given for a correct method even if the answer is incorrect.
- Do **not** write in the bar codes.

INFORMATION

- The total mark for this paper is **90**.
- The marks for each question are shown in brackets [].
- Quality of extended responses will be assessed in questions marked with an asterisk (*).
- This document consists of **20** pages.

1 Fig. 1 shows a drone.

(Image of a drone redacted due to third party copyright restrictions)

Fig. 1

(a) The camera and the battery in Fig. 1 are located underneath the drone.

Explain **one** reason why the camera and battery located in this position enhances the performance of the drone.

.....
.....

.....[2]

- (b) The drone is controlled by an electronic system.
Fig. 2 shows the system diagram.

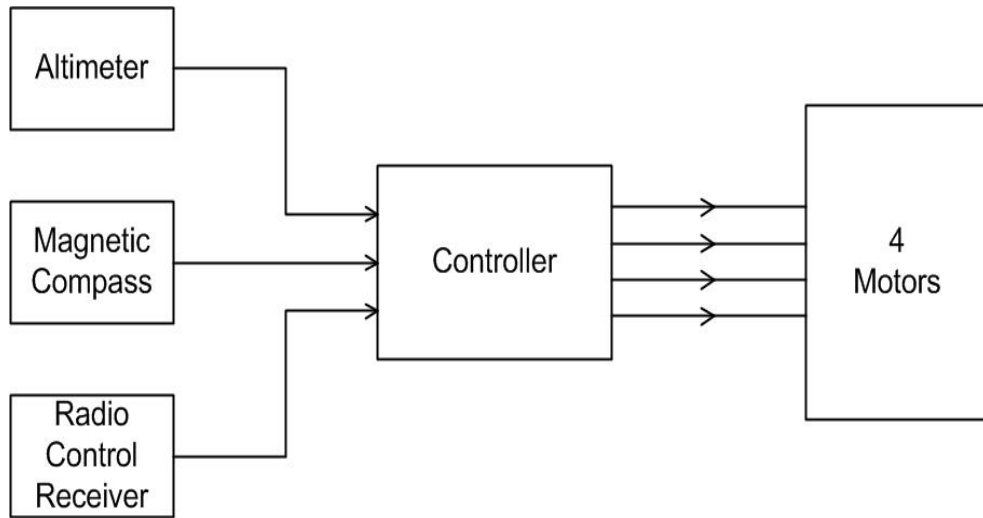

Fig. 2

- (i) The controller is a programmable device.

Analyse the system diagram to describe how the controller supports the functionality of the drone.

.....
.....
.....[2]

- (ii) The drone can be set to hover at a constant altitude, without any user input.

Describe how the system uses **feedback** to achieve this.

.....
.....
.....
.....
.....
.....[3]

- (c) The body of the drone has been manufactured from ABS.

Explain **two** reasons why ABS is a suitable material for the body of the drone.

1.....

.....

.....

2.....

.....

.....[4]

- (d) Data for the drone is given below:

- Mass: $\frac{3}{2}$ kg
- Diameter of propellers: 250 mm
- Battery: lithium ion 11.1 V

- (i) Calculate the weight of the drone, assuming a gravitational field strength of 9.8 N kg^{-1} . You **must** state the formula used in your calculation.

weight = N [2]

- (ii) The total power (in watts) required for the drone to hover is given by the following formula:

$$P = 0.18 \frac{W^{3/2}}{r}$$

where W is the weight of the drone (in newtons), and r is the radius of one propeller (in metres).

Use the information in the question, and your knowledge of electrical principles, to calculate the total current drawn from the battery when the drone is hovering. You **must** state any formulae used in your calculation.

current = [4]

2 **Table 1** shows anthropometric data for a human hand.

	Dimensions (mm)	Age Range 19–65					
		Men (Percentiles)			Women (Percentiles)		
		5%	50%	95%	5%	50%	95%
1	Hand length	170.0	190.0	210.0	160.0	175.0	190.0
2	Hand breadth	80.0	90.0	100.0	70.0	80.0	90.0
3	Thumb breadth (diameter)	20.0	23.0	26.0	16.0	19.0	22.0
4	Thumb length	44.0	51.0	58.0	40.0	47.0	53.0
5	Forefinger tip breadth (index finger)	18.0	21.0	24.0	15.0	18.0	21.0
6	Forefinger length (index finger)	64	72	80	60	67	74
7	Hand thickness (minimum hand clearance)	44.0	51.0	58.0	40.0	45.0	50.0

Table 1

(a) Anthropometric data of hands is important when determining the size for a computer games controller to fit the greatest number of consumers.

Fig. 3 shows how a games controller is held.

Fig. 4 shows a plan view of the games controller.



Fig. 3

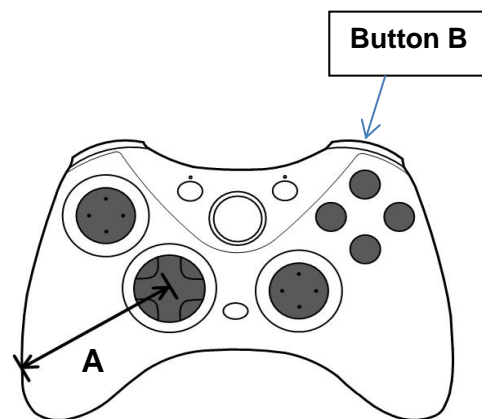

Fig. 4

Use the data from **Table 1** to answer the following questions.

- (i) User group analysis has determined that measurement **A** should ideally be 1.2 times the length of the user's thumb.

Calculate a value for measurement **A** based on the average thumb length across the adult population, assuming there are an equal number of men and women.

Measurement A=..... [2]

- (ii) Button B at the front of the games controller relies on the user having a forefinger length of 65mm or greater.

Calculate the approximate percentage of adult women that are excluded from being able to use this button.

Percentage excluded% [3]

- (b) Games controllers are designed to favour male primary users, both in relation to measurements and design. Market research indicates that there is an increase in the number of female users engaging with computer games.

Describe a strategy that a designer could take to ensure the games controller is more balanced in its appeal to both men and women.

.....
.....
.....
.....[2]

- (c) The casing of the games controller is made from a polymer with a density of 1.08 g cm^{-3} and a cost of £50 per 20 kg.

80 cm³ of polymer is used in the manufacture of each casing.

- (i) Calculate the material cost of 50 000 games controller casings.

Cost = £.....[3]

- (ii) A designer plans to make a children’s version of the games controller, where the width and length are both reduced by a 0.75 scaling factor.

Calculate the volume of polymer that would be used in the casing of the children’s games controller, assuming that the thickness remains unchanged.

Volume =.....[2]

3 Fig. 5 shows a robotic vacuum cleaner.



Fig. 5

(a) The robotic vacuum cleaner uses sensors whilst it cleans.

Identify **one analogue** sensor and **one digital** sensor that would be used in the robotic vacuum cleaner and describe how the data produced by each sensor is used to assist the cleaning operation.

Analogue

.....

.....

Digital

.....

.....[4]

(b) The robotic vacuum cleaner uses DC motors to drive the wheels.

Describe how the speed and direction of a DC motor can be controlled by an electronic system.

.....

.....

.....

.....[2]

- (c) Draw a flow chart to show how the electronic system for the robotic vacuum cleaner might detect, respond to and avoid obstacles.

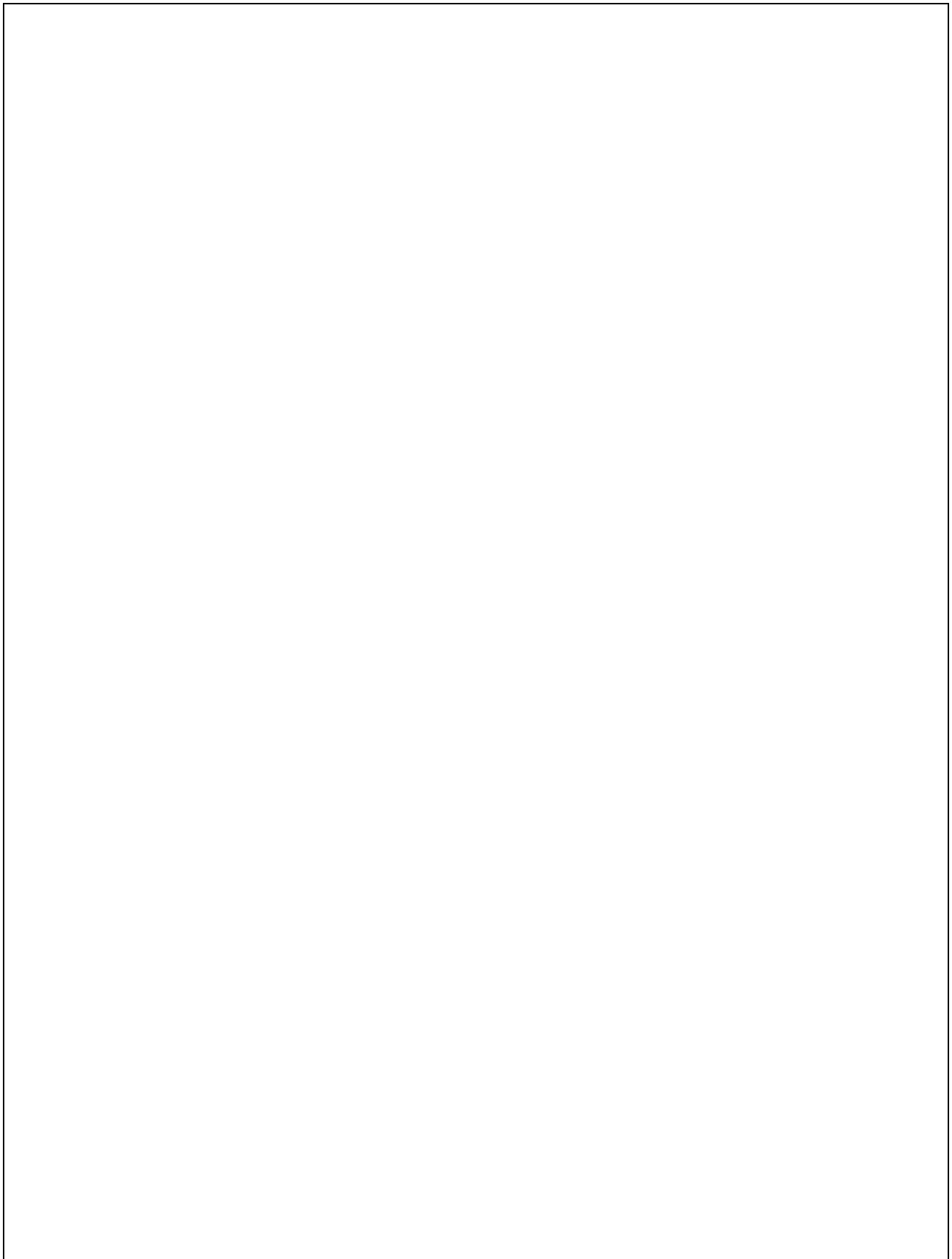

[4]

- (d) The vacuum cleaner calculates the time to clean a room based on the floor area.

The vacuum cleaner travels at a speed of 0.4 ms^{-1} .

In one particular rectangular room, the longest uninterrupted run is 12 s. This run is assumed to be along the diagonal of the room from corner to corner. This room has a length to width ratio of 4:3.

Calculate the floor area of this room.

Area =m² [5]

PLEASE TURN OVER FOR QUESTION 4

- 4 A design engineer is solving a problem for a laundry. The laundry process requires the level of water in a tank to be maintained between two sensors. The water tank system is shown in **Fig. 6**.

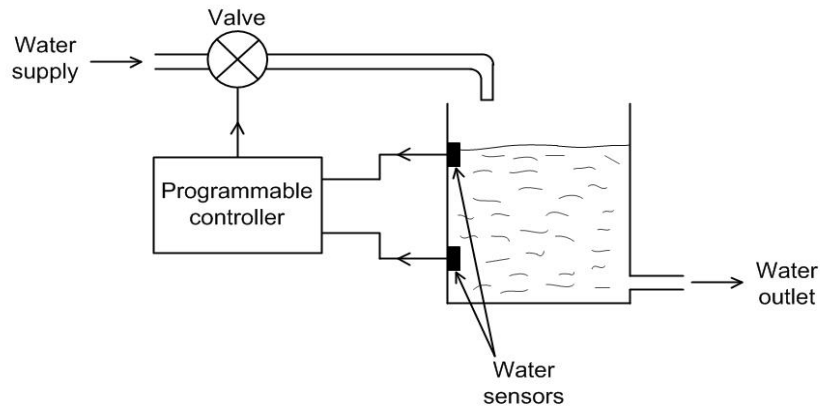

Fig. 6

If the water level drops below the lower sensor then the programmable controller opens the valve which allows the tank to fill. When the water level reaches the upper sensor, the valve closes again.

The design engineer wishes to use a double-acting pneumatic cylinder as the actuator for the valve.

Fig. 7 shows the cylinder and valve in position. The valve is shown in the CLOSED position. When the cylinder outstrokes, it rotates the valve arm 90° to the OPEN position, shown by the dotted lines.

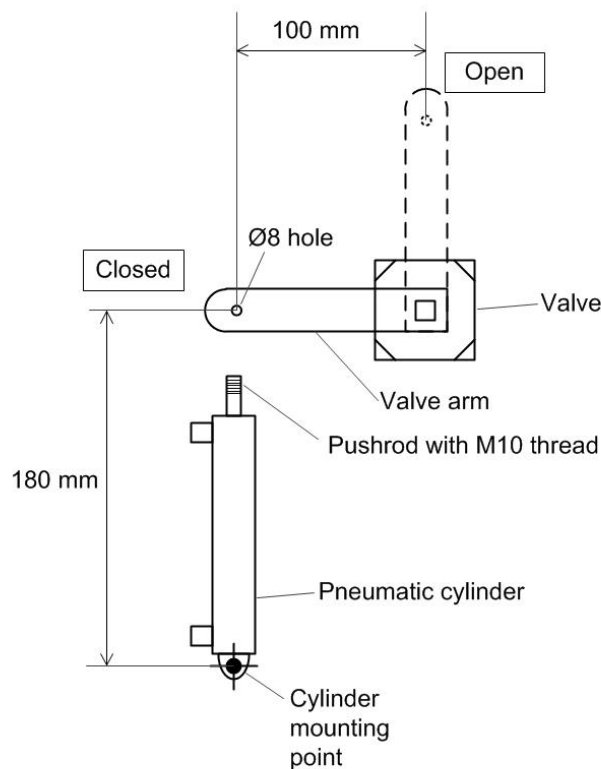

Fig.7

- (a) The pushrod is to be linked to the valve arm using appropriate components that need to be manufactured. The component must allow the valve arm to rotate to the OPEN position when the pneumatic cylinder outstrokes.
 - (i) Analysing the information from **Fig. 7**, use sketches and notes to show a linkage component suitable for this specific application. Show any additional components needed to connect this component to the pneumatic cylinder and the valve arm.

[4]

- (ii) Explain **two** ways in which new technologies could assist in the design and manufacture of a linkage component for this application.

1.....
.....
.....
.....
.....

2.....
.....
.....
.....

..... [4]

- (b) (i) Using the information in **Fig. 7**, complete the diagram below to show how the pneumatic cylinder would be connected to the valve arm when in its outstroke position.

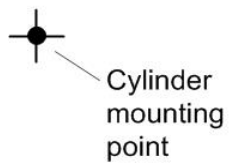
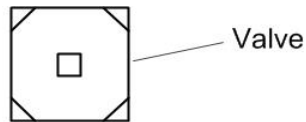

[3]

- (ii) Analyse the data in **Fig. 7** to calculate, by a mathematical method, the pneumatic cylinder stroke required (*stroke* is the distance the pushrod extends when the cylinder is operated). You **must** show your working out.

Cylinder stroke.....mm [5]

- (c) (i) Identify the interface component which would allow the pneumatic cylinder to be controlled by the programmable controller

Name of interface component[1]

- (ii) Analyse the information in **Fig. 6**, and draw a complete circuit diagram to show how the interface component would be connected between the programmable controller and the double-acting pneumatic cylinder.

The diagram should show enough information to allow a non-specialist person to correctly connect all the components so that the system will function.

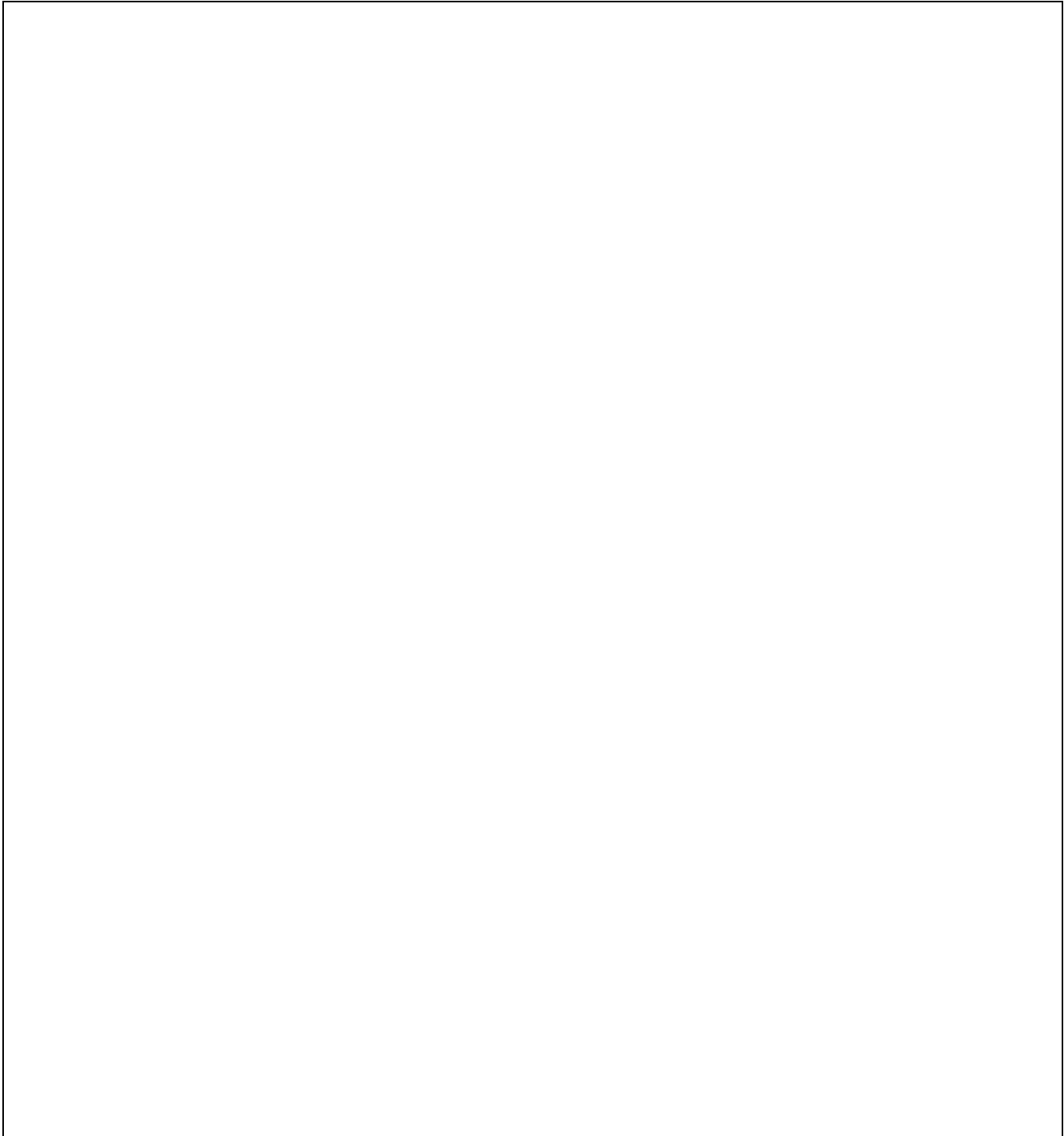

[4]

BLANK PAGE

BLANK PAGE

Summary of updates

Date	Version	Details
April 2022	3.2	Updated copyright acknowledgements. Figure 1 – image of a drone, redacted due to third party copyright restrictions.

Copyright Information:

© xveron90x, Shutterstock Photo Library, www.shutterstock.com

OCR is committed to seeking permission to reproduce all third-party content that it uses in the assessment materials. OCR has attempted to identify and contact all copyright holders whose work is used in this paper. To avoid the issue of disclosure of answer-related information to candidates, all copyright acknowledgements are reproduced in the OCR Copyright Acknowledgements booklet. This is produced for each series of examinations and is freely available to download from our public website (www.ocr.org.uk) after the live examination series.

If OCR has unwittingly failed to correctly acknowledge or clear any third-party content in this assessment material, OCR will be happy to correct its mistake at the earliest possible opportunity.

For queries or further information please contact the OCR Copyright Team, The Triangle Building, Shaftesbury Road, Cambridge, CB2 8EA.

OCR is part of Cambridge University Press and Assessment, which is itself a department of the University of Cambridge.



Oxford Cambridge and RSA

...day June 20XX – Morning/Afternoon

AS Level in Design and Technology: Design Engineering

H004/01 Principles of Design Engineering

SAMPLE MARK SCHEME

Duration: 1 hour 45 minutes

MAXIMUM MARK 90



This document consists of 28 pages

PREPARATION FOR MARKING**SCORIS**

1. Make sure that you have accessed and completed the relevant training packages for on-screen marking: *scoris assessor Online Training*; *OCR Essential Guide to Marking*.
2. Make sure that you have read and understood the mark scheme and the question paper for this unit. These are posted on the RM Cambridge Assessment Support Portal <http://www.rm.com/support/ca>
3. Log-in to scoris and mark the **required number** of practice responses (“scripts”) and the **required number** of standardisation responses.

YOU MUST MARK 10 PRACTICE AND 10 STANDARDISATION RESPONSES BEFORE YOU CAN BE APPROVED TO MARK LIVE SCRIPTS.

MARKING

1. Mark strictly to the mark scheme.
2. Marks awarded must relate directly to the marking criteria.
3. The schedule of dates is very important. It is essential that you meet the scoris 50% and 100% (traditional 50% Batch 1 and 100% Batch 2) deadlines. If you experience problems, you must contact your Team Leader (Supervisor) without delay.
4. If you are in any doubt about applying the mark scheme, consult your Team Leader by telephone, email or via the scoris messaging system.

5. Work crossed out:
 - a. where a candidate crosses out an answer and provides an alternative response, the crossed out response is not marked and gains no marks
 - b. if a candidate crosses out an answer to a whole question and makes no second attempt, and if the inclusion of the answer does not cause a rubric infringement, the assessor should attempt to mark the crossed out answer and award marks appropriately.
6. Always check the pages (and additional objects if present) at the end of the response in case any answers have been continued there. If the candidate has continued an answer there then add a tick to confirm that the work has been seen.
7. There is a NR (No Response) option. Award NR (No Response)
 - if there is nothing written at all in the answer space
 - OR if there is a comment which does not in any way relate to the question (e.g. 'can't do', 'don't know')
 - OR if there is a mark (e.g. a dash, a question mark) which isn't an attempt at the question.Note: Award 0 marks – for an attempt that earns no credit (including copying out the question).
8. The scoris **comments box** is used by your Team Leader to explain the marking of the practice responses. Please refer to these comments when checking your practice responses. **Do not use the comments box for any other reason.** If you have any questions or comments for your Team Leader, use the phone, the scoris messaging system, or email.
9. Assistant Examiners will send a brief report on the performance of candidates to their Team Leader (Supervisor) via email by the end of the marking period. The report should contain notes on particular strengths displayed as well as common errors or weaknesses. Constructive criticism of the question paper/mark scheme is also appreciated.

10. Annotations

Annotation	Meaning
BP	Blank page
✓	Point where mark is awarded
x	Incorrect response
L1	Level one response
L2	Level two response
L3	Level three response
ECF	Error carried forward
BOD	Benefit of doubt accepted
REP	Repetition
SEEN	Noted, but no credit given
PD	Poor Diagram offering unclear response

11. Subject-specific Marking Instructions

INTRODUCTION

Your first task as an Examiner is to become thoroughly familiar with the material on which the examination depends. This material includes:

- the specification, especially the assessment objectives
- the question paper
- the mark scheme.

You should ensure that you have copies of these materials.

You should ensure also that you are familiar with the administrative procedures related to the marking process. These are set out in the OCR booklet **Instructions for Examiners**. If you are examining for the first time, please read carefully **Appendix 5 Introduction to Script Marking: Notes for New Examiners**.

Please ask for help or guidance whenever you need it. Your first point of contact is your Team Leader.

The breakdown of Assessment Objectives for AS Level in Design & Technology

	Assessment Objective
AO3	Analyse and evaluate – <ul style="list-style-type: none"> • design decisions and outcomes, including for prototypes made by themselves and others • wider issues in design and technology
AO3.1a	Analyse design decisions and outcomes, including for prototypes made by themselves and others
AO3.1b	Evaluate design decisions and outcomes, including for prototypes made by themselves and others
AO3.2a	Analyse wider issues in design and technology
AO3.2b	Evaluate wider issues in design and technology
AO4	Demonstrate and apply knowledge and understanding of – <ul style="list-style-type: none"> • technical principles • design and making principles
AO4.1a	Demonstrate knowledge of technical principles
AO4.1b	Demonstrate understanding of technical principles
AO4.1c	Apply knowledge and understanding of technical principles
AO4.2a	Demonstrate knowledge of design and making principles
AO4.2b	Demonstrate understanding of design and making principles
AO4.2c	Apply knowledge and understanding of design and making principles

Question			Answer	Marks	Guidance
1	(a)		<p>How camera and battery location enhances performance, e.g.:</p> <p>To lower the centre of gravity (✓) in order to improve the stability of the drone when it is flying (✓)</p> <p>Other possible reasons include:</p> <ul style="list-style-type: none"> • So that the camera has a clear view of the ground to improve the quality of the photographs • So that the battery is easily accessible for ease of changing so the drone can quickly be re-flown <p>Award credit for any other appropriate response</p>	<p>2</p> <p>AO3</p> <p>1 x 1b</p> <p>AO4</p> <p>1 x 2c</p>	<p>1 mark for a correct reason why the drone's performance is enhanced</p> <p>1 mark for justifying the significance</p> <p>Responses may make reference to the camera and the battery, or just the camera, or just the battery.</p> <p>Do not award marks for aesthetic reasons.</p>
1	(b)	(i)	<p>The controller receives inputs from three sensors (✓) and uses these to control the output of the motor (✓)</p> <p>Award credit for any other appropriate response</p>	<p>2</p> <p>AO3</p> <p>1a</p>	<p>2 marks for a description of how the controller supports the functionality of the drone.</p> <p>Specific reference to the components of the system diagram is needed for the marks.</p>
1	(b)	(ii)	<p>How the system operates to maintain altitude, e.g.:</p> <p>The altimeter provides data about the altitude of the drone and the controller compares this to the desired altitude value. (✓) If the altitude is wrong, the controller adjusts the motor speeds which changes the altitude. (✓) The new altitude is fed back to the altimeter and the process repeats. (✓)</p> <p>Award credit for any other appropriate response</p>	<p>3</p> <p>AO4</p> <p>1c</p>	<p>3 marks for a description of how the system operates to maintain altitude that demonstrates an understanding of feedback.</p> <p>The description of feedback must be in the context of the drone's system.</p>
1	(c)		<p>Relevant properties of ABS and linked to the body of the drone, e.g.:</p> <p>ABS has good impact resistance (✓) so it is less likely to crack should the drone collide with obstacles (✓)</p>	<p>4</p> <p>AO4</p> <p>4 x 1c</p>	<p>1 mark for identifying each of two relevant properties of ABS</p> <p>1 marks for explaining how each property is suitable for the body of drone.</p>

Question			Answer	Marks	Guidance
			<p>ABS has a high strength to weight ratio (✓) so that the body has good tensile strength without adding unnecessarily to the weight of the aircraft (✓)</p> <p>Other possible answers include:</p> <ul style="list-style-type: none"> • ABS is a good electrical insulator so that there is no chance of short circuits between electrical components which may be mounted to the casing • ABS is not affected by the sun or rain and does not become brittle in low outdoor temperatures so it will be durable for outdoor use around the year • ABS is a thermoplastic so it can be injection moulded into the complex shapes for the drone body, allowing for larger scale production at low cost • ABS can be given a high quality finished during the moulding process which will enhance the drone's image and give user appeal. <p>Award credit for any other appropriate response</p>		Specific reference to the use of ABS in relation to the body of the drone is needed for the marks.
1	(d)	(i)	<p>Weight = mass x gravitational field strength (✓)</p> <p>$W = 3/2 \times 9.8$ $W = 14.7\text{N}$ (✓)</p>	<p>2</p> <p>A04 1c</p>	<p>1 mark for stating the scientific formula for weight. 1 mark for substituting values into formula and calculating answer.</p> <p>Formula and answer are required for full marks.</p>
1	(d)	(ii)	<p>$250\text{ mm} \div 2 = 0.125\text{m}$ (✓)</p> <p>$P = \frac{0.18 \times 14.7 \left(\frac{3}{2}\right)}{0.125^*}$</p> <p>$= 81.16\text{W}$ (✓)</p> <p>$I = P/V$ or equivalent (✓)</p> <p>$I = 81.16^* / 11.1$ $I = 7.31\text{ A}$ (✓)</p>	<p>4</p> <p>A04 1c</p>	<p>Allow error carried forward (ECF) from 1di for the weight</p> <p>1 mark for converting radius of one propeller to metres. 1 mark for substituting values into formula and calculating answer. 1 mark for recalling the correct scientific formula (power ÷ volts) 1 mark for substituting values into formula and calculating answer</p> <p>*Allow error carried forward (ECF) where correct working out is shown.</p>

Question	Answer	Marks	Guidance
			Correct answer scores full marks.

Question		Answer	Marks	Guidance	
				Contents	Levels of response
1	(e)	<p><i>Indicative content:</i></p> <p>Negative issues:</p> <ul style="list-style-type: none"> • Drones can be used to fly over private land which poses security and privacy issues, and they can then take photos or stream live video without people knowing, e.g. they have been used to photograph celebrities sunbathing. • Drones can be used for illegal or irresponsible purposes where other methods put the user at greater risk of being caught, e.g. they have been used to deliver drugs and other illegal items to prisoners inside prison. • Drones are heavy airborne machines which can be dangerous if they hit people or property. This can happen with inexperienced or irresponsible pilots or in situations where drones are being flown in busy public areas built-up areas, e.g. parks or towns. • Badly maintained drones can fail in flight and fall out of the sky posing significant risk of damage or injury, e.g. propellers frequently come off or badly maintained batteries will fail with very little warning. • There have been reports of irresponsibly flown drones endangering aircraft on final approach, and drones being flown at farm animals which causes worry and is cruel. • There are signs that drones might be starting to replace certain workers' jobs at much lower cost, e.g. taking aerial photos, which would normally involve a pilot in a helicopter or plane, or Amazon.com developing their aerial delivery service, which obviously replaces delivery 	<p>6</p> <p>AO3 2 x 2b</p> <p>AO4 4 x 2c</p>	<p>All issues raised in the candidate's response must be in relation to ethical issues associated with the use of drones.</p> <p>A candidate operating at Level 3 would be expected to access all of the AO4 (2c) marks and at least one of the AO3 (2b) marks.</p> <p>A candidate operating at Level 2 would be expected to access most of the AO4 (2c) marks, and at least one of AO3 (2b) marks.</p> <p>A candidate operating at Level 1 would be expected to access AO4 (2c) marks.</p>	<p>Level 3 (5–6 marks)</p> <p>The candidate produces a thorough discussion of the ethical issues raised by the use of drones, identifying both positive and negative issues. The candidate shows a mature understanding and evaluates the wider issues in the question through the use of examples and their discussion is more cohesive and well-considered as a result.</p> <p>Level 2 (3–4 marks)</p> <p>The candidate produces a sound discussion of the ethical issues raised by the use of drones, identifying positive and/or negative issues. The candidate shows a reasonable understanding and evaluates the wider issues in the question through the use of examples and their discussion is for the most part cohesive and well-considered.</p> <p>Level 1 (1–2 marks)</p> <p>The candidate limited understanding of the ethical issues raised by the use of drones, identifying only positive or negative issues. There is little</p>















		<p>drivers.</p> <ul style="list-style-type: none"> • Pilotless aircraft have become associated with military strikes, and this 'killing at a distance' is considered immoral by some people, e.g. US military drone attacks in Afghanistan. • they can be fitted with 'FPV' cameras which allow the pilot to wear goggles to give them a 'pilots-eye view'. This allows the drone to be flown completely out of direct sight of the pilot which exacerbates the security issues and could result in the drone being flown out of radio control range. <p>Positives issues:</p> <ul style="list-style-type: none"> • Drones can be used to carry items into, or photograph in locations which would normally not be accessible, e.g. to photograph and drop equipment in treacherous conditions to support aid and rescue work. • Drones can be used to monitor issues from an aerial perspective that may not be easy to observe or understand from the ground, e.g. monitoring deforestation, conservation or environmental impact in a certain situation. • Drones can be used to offer security surveillance and observe crowd behaviour from an aerial perspective giving valuable information that cannot be made from the ground. <p>Award credit for any other appropriate response</p>			<p>consideration of wider issues in the question and there is no evaluation.</p> <p>Level 0 (0 marks)</p> <p>No response or no response worthy of credit.</p>
--	--	----------------------------------------------------------------------------------------------------------------------------------------------------------------------------------------------------------------------------------------------------------------------------------------------------------------------------------------------------------------------------------------------------------------------------------------------------------------------------------------------------------------------------------------------------------------------------------------------------------------------------------------------------------------------------------------------------------------------------------------------------------------------------------------------------------------------------------------------------------------------------------------------------------------------------------------------------------------------------------------------------------------------------------------------------------------------------------------------------------------------------------------------------------------------------------------------------------------------------------------------------------------------------------------------------------------------------------------------------------------	--	--	----------------------------------------------------------------------------------------------------------------------------------------------------------------------

Question			Answer	Marks	Guide
2	(a)	(i)	<p>Male 51mm, Female 47mm Average thumb length = $(51 + 47) / 2 = 49$ (✓)</p> <p>Measurement A = 1.2 x average thumb length Measurement A = 1.2 x 49* Measurement A = 58.8 mm (✓) (Allow 59 mm)</p>	<p>2</p> <p>AO3 1 x 1a</p> <p>AO4 1 x 1c</p>	<p>1 mark for extracting the average (50th percentile) thumb lengths for male and female from Table 1 and calculating an average.</p> <p>1 mark for for calculating measurement A.</p> <p>*Allow error carried forward (ECF) where correct working out is shown.</p> <p>Allow full marks for the final answer with no working shown</p>
2	(a)	(ii)	<p>65mm length is 2mm less than 50% percentile (✓)</p> <p>Percentile range $50 - 5 = 45\%$ Forefinger length range $67 - 60 = 7\text{mm}$ $45 \div 7 = 6.42\%$ per mm (✓)</p> <p>$6.42^* \times 2 = 12.86$ $50 - 12.86 = 37.14\%$ (✓)</p> <p>Award credit for any other appropriate method of calculation</p>	<p>3</p> <p>AO3 1 x 1a</p> <p>AO4 2 x 1c</p>	<p>1 mark for identifying where the 65mm forefinger length fits within the percentile range for women. 1 mark for calculating down the proportional forefinger length per percentage unit. 1 mark for calculating the percentage excluded from being able to use the button.</p> <p>*Allow error carried forward (ECF) where correct working out is shown.</p> <p>Correct answer scores full marks.</p>
2	(b)		<p>Strategy to ensure wider user appeal of the games controller, e.g.:</p> <p>User-centred approach (✓), in which extensive attention is given to the needs and wants of the games controller users of both genders (✓)</p> <p>Other possible strategies include:</p>	<p>2</p> <p>AO4 2c</p>	<p>1 mark for identification of an appropriate strategy 1 mark for describing how the strategy can ensure wider user appeal to both sexes.</p>

			<ul style="list-style-type: none"> • Aesthetic neutrality, in which the shapes, sizes, colours used do not bias towards either gender, e.g. could refer to shape of hand-holds not being 'male' or colour of casing not being 'female' • Ergonomic neutrality, in which the dimensions, layout of controls, etc. do not favour either gender, e.g. large forces needed to operate controls, inability to press buttons with long fingernails • Consideration of the system design, so that the components, modules and interfaces do not bias towards gender • Software design, where the functionality of the controller does not favour or discriminate against either gender • Marketing and branding focus, in which both genders are evenly represented and the appeal of the controller is demonstrated to be equal between both sexes. <p>Award credit for any other appropriate response</p>		Specific reference to a design strategy in relation to the games controller is needed for the marks.
2	(c)	(i)	<p>Mass = volume x density (✓)</p> <p>Mass = 80 x 1.08 = 86.4g (0.0864kg) (✓)</p> <p>Cost per kg = 50 ÷ 20 = £2.50</p> <p>Cost for 50 000 casings = 50 000 x 0.0864* x 2.5 = £10 800 (✓)</p> <p>Award marks for alternative methods of calculation</p>	3 AO4 2c	<p>1 mark for recall of correct formula</p> <p>1 mark for substituting into the formula and calculating mass of one casing.</p> <p>1 mark for calculating total material cost.</p> <p>*Allow error carried forward (ECF) where correct working out is shown.</p> <p>Correct answer scores full marks.</p>
2	(c)	(ii)	<p>The volume will be reduced by $0.75 \times 0.75 = 0.5625$ (✓)</p> <p>Therefore, the new volume will be $80 \times 0.5625 = 45\text{cm}^3$ (✓)</p>	2 AO4 1c	<p>1 mark for the volume scaling factor.</p> <p>1 mark for the volume calculation.</p> <p>Correct answer scores full marks.</p>

Question	Answer	Marks	Guidance
<p>3 (a)</p>	<p>Analogue and digital sensors and how the data from each sensor is used to assist the cleaning operation, e.g.:</p> <ul style="list-style-type: none"> • Analogue - an infra-red distance sensor (✓) could be used to measure the distance between the robot and an obstacle so that the robot does not have to bump into the obstacle to detect it, which avoids damage to furniture (and robot) (✓) • Digital – dirt bin level sensor (✓) which would give a logic 1 signal to indicate the dirt bin is full; this would tell the robot to stop cleaning and sound an alert (✓) <p>Other possible sensors include:</p> <p><u>Analogue</u></p> <ul style="list-style-type: none"> • Ultrasonic rangefinder – measures distance by reflecting high frequency sound pulses off the obstacle and timing the delay (SONAR), this provides data for the robot which allows it to slow down and manoeuvre around obstacles which avoids the need for reversing • Battery voltage level sensor – informs the robot about the condition of the battery and allows it to calculate the time remaining before needing recharging. <p><u>Digital</u></p> <ul style="list-style-type: none"> • Dirt bin correctly in place sensor – will stop the robot and sound an alert if the dust bin is not securely in place. • Cleaning brushes sensor – would indicate whether the brushes are rotating or not, which could be used to sense if the brushes become obstructed. • Push buttons on control panel – each button is a digital sensor which, when pressed, sends a logic 1 signal to the microcontroller which will then respond appropriately <p>Award credit for any other appropriate response</p>	<p>4</p> <p>AO4 1c</p>	<p>1 mark for identifying an analogue sensor</p> <p>1 mark for describing how the analogue sensor uses data to assist the cleaning.</p> <p>1 mark for identifying a digital sensor</p> <p>1 mark for describing how the digital sensor uses data to assist the cleaning.</p> <p>Specific reference to sensors used in relation to the robotic vacuum cleaner is needed for the marks.</p>

Question		Answer	Marks	Guidance
3	(b)	<p>How speed and direction are controlled, e.g.:</p> <p>The speed can be controlled by controlling the current through the motor (or, varying the voltage across the motor) (✓)</p> <p>The direction is controlled by reversing the current flow, which can be done with a dpdt relay: (✓)</p> <p>Other possible speed control responses include:</p> <ul style="list-style-type: none"> • The voltage applied to the motor is varied • A pulse width modulation (PWM) method can be used • The analogue output pin from a microcontroller can be used <p>Other possible direction control responses include:</p> <ul style="list-style-type: none"> • The current is reversed • The applied voltage is reversed • An H-bridge driver (motor driver ic) can be used <p>Award credit for any other appropriate response</p>	<p>2</p> <p>AO4</p> <p>1a</p>	<p>1 mark for describing how motors speed can be controlled.</p> <p>1 mark for describing how motors direction can be controlled.</p> <p>Do not accept two answers that cover speed or direction.</p>

Question	Answer	Marks	Guidance																		
<p>3 (c)</p>	<p>Example below:</p> <p>Award credit for any other appropriate response</p> <table border="1" data-bbox="376 355 822 783"> <thead> <tr> <th>Symbol</th> <th>Name</th> <th>Function</th> </tr> </thead> <tbody> <tr> <td></td> <td>Start/end</td> <td>An oval represents a start or end point</td> </tr> <tr> <td></td> <td>Arrows</td> <td>A line is a connector that shows relationships between the representative shapes</td> </tr> <tr> <td></td> <td>Input/Output</td> <td>A parallelogram represents input or output</td> </tr> <tr> <td></td> <td>Process</td> <td>A rectangle represents a process</td> </tr> <tr> <td></td> <td>Decision</td> <td>A diamond indicates a decision</td> </tr> </tbody> </table> <div data-bbox="862 539 1435 1201" style="text-align: center;"> <p>(✓)</p> <pre> graph TD Start([Start sub system]) --> D1{Is there something closer than 30 cm?} D1 -- No (✓) --> M1[Move forward] M1 --> Start D1 -- Yes --> S1[Stop moving] S1 --> T1[Turn left] T1 --> R1[Take a reading] R1 --> T2[Turn right] T2 --> R2[Take a reading] R2 --> D2{Is the left distance smaller than right distance?} D2 -- Yes --> M2[Move forward] M2 --> Start D2 -- No (✓) --> T3[Turn left] T3 --> M3[Move forward] M3 --> Start </pre> </div>	Symbol	Name	Function		Start/end	An oval represents a start or end point		Arrows	A line is a connector that shows relationships between the representative shapes		Input/Output	A parallelogram represents input or output		Process	A rectangle represents a process		Decision	A diamond indicates a decision	<p>4</p> <p>AO4 1 x 1a 3 x 1c</p>	<p>1 mark for knowing how to set out a flowchart correctly using the correct symbols:</p> <p>1 mark for showing appropriate inputs and outputs.</p> <p>1 mark for showing appropriate decisions that the system makes.</p> <p>1 mark for showing an appropriate process that ensures the system is continuous (yes/no) regardless of decision outcomes.</p> <p>Specific reference to actions of an electronic system in relation to the robotic vacuum cleaner is needed for the marks.</p> <p>Candidates can draw on practical experience from product analysis to support their response to this question.</p>
Symbol	Name	Function																			
	Start/end	An oval represents a start or end point																			
	Arrows	A line is a connector that shows relationships between the representative shapes																			
	Input/Output	A parallelogram represents input or output																			
	Process	A rectangle represents a process																			
	Decision	A diamond indicates a decision																			
<p>3 (d)</p>	<p>distance = speed x time $d = 0.4 \times 12 = 4.8\text{m}$ (✓)</p>	<p>5</p> <p>AO4 1c</p>	<p>1 mark for calculation of room's diagonal dimension recalling formula.</p> <p>1 mark for calculating the diagonal angle of the room converting ratio.</p> <p>1 mark for calculating the length of</p>																		

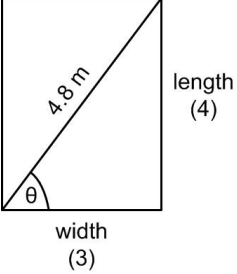
Question	Answer	Marks	Guidance
	 <p> $\tan \theta = 4/3$ $\theta = 53.1^\circ (\checkmark)$ </p> <p> $\text{length} = 4.8 * \sin 53.1 = 3.84\text{m} (\checkmark)$ $\text{width} = 4.8 * \cos 53.1 = 2.88\text{m} (\checkmark)$ </p> <p> One mark for calculation of area: $\text{Area} = \text{length} \times \text{width}$ $\text{Area} = 3.84 * 2.88^*$ $\text{Area} = 11.06\text{m}^2 (\checkmark)$ </p> <p>Award credit for solution by any other appropriate method</p>		<p>the room. 1 mark for calculating the width of the room. 1 mark for calculating the area of the room.</p> <p>*Allow error carried forward (ECF) where correct working out is shown.</p> <p>Correct answer scores full marks.</p>
<p>4 (a) (i)</p>	<p>Sketches and/or notes may include:</p> <p>M10 threaded hole to accept the pushrod end</p> <p>Method of connecting to the Ø8 hole on the valve arm</p> <p>Connection to valve arm must allow for rotation</p> <p>Connection to valve arm must be secure and not able to fall out</p>	<p>4</p> <p>AO3 1 x 1a</p> <p>AO4 3 x 1c</p>	<p>1 mark for identifying appropriate information from the analysis of Fig.9.</p> <p>1 mark for clearly sketching an appropriate linkage component</p> <p>1 mark for clearly sketching appropriate additional components to connect the linkage to the valve and cylinder.</p> <p>1 mark for accurate annotation of all</p>

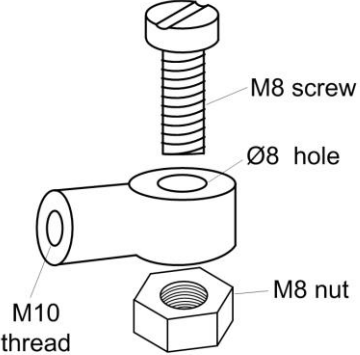
Question	Answer	Marks	Guidance
	<p>Example solution:</p>  <p>Award credit for any other appropriate response</p>		<p>parts.</p> <p>Solutions need to be fully appropriate to the outlined problem for the marks.</p> <p>Candidates can draw on practical experience from workshop experience and product analysis to support their response to this question.</p>
<p>4 (a) (ii)</p>	<p>How new technologies can assist the design and manufacture of the linkage, e.g.:</p> <p>A digitally designed linkage could be analysed with CAE software (✓), to test material strength/flexing/durability etc. (✓)</p> <p>New material technology could be explored (✓), to improve the performance, considering the needs of this situation, e.g. strength/flexing/durability/water resistance, low friction. (✓)</p> <p>Other possible responses may include:</p> <ul style="list-style-type: none"> • The linkage could be modelled through the use of 3D rapid prototyping, and this part could then be used in a digital model to test the movement of the mechanical system • Once modelled through digital design the file could be sent for 3D printing or CNC machining, which would be a lost cost/high accuracy/fast method of 	<p>4</p> <p>AO4 1c</p>	<p>1 mark for each of two valid identifications of ways in which new technologies could assist in the design and manufacture of the linkage.</p> <p>2 further marks for explaining in relation to use for the pneumatic cylinder in this water tank scenario.</p> <p>Specific reference to the linkage in relation to the pneumatic cylinder of the water tank is needed for the marks.</p>

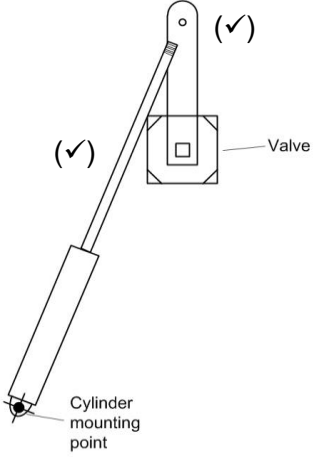
Question			Answer	Marks	Guidance
			producing the linkage part. Award credit for any other appropriate response		
4	(b)	(i)	<p>The diagram should be completed as shown:</p> 	<p>2 AO3 1 x 1a AO4 1 x 1c</p>	<p>1 mark for correctly identifying from Fig. 9 where the valve arm would be located in an open position and drawing it.</p> <p>1 mark for correctly drawing the pneumatic cylinder with the pushrod in an extended position and running between the mounting point and the valve arm hole. The length of cylinder should be in roughly the same proportion as that in Fig.9 for this mark to be awarded.</p>

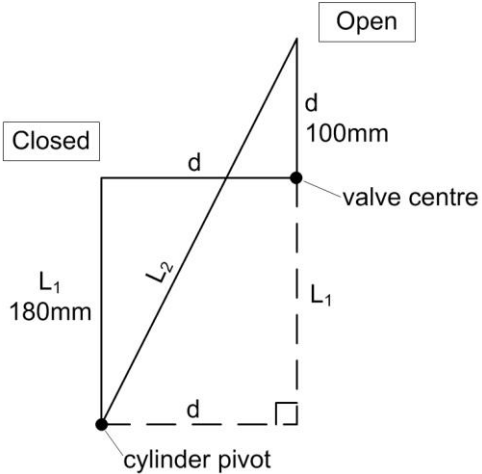
Question	Answer	Marks	Guidance
<p>4 (b) (ii)</p>	 <p style="text-align: center;">(✓)</p> <p>From the diagram, it is apparent that L_2 is the hypotenuse of a right angle triangle with sides d and $(L_1 + d)$ (evidence for this can be a clearly drawn diagram) (✓)</p> $L_2^2 = d^2 + (L_1 + d)^2 \text{ (✓)}$ $L_2^2 = 100^2 + (180 + 100)^2$ $L_2^2 = 88400$ $L_2 = 297\text{mm} \text{ (✓)}$ <p>Cylinder stroke = $L_2 - L_1$ stroke = $297 - 180$ stroke = $117\text{mm} \text{ (✓)}$</p> <p>Award credit for any other appropriate response</p>	<p>5</p> <p>AO3 2 x 1a</p> <p>AO4 3 x 1c</p>	<p>2 marks for analysing the information in Fig. 9 to determine a method for solving the problem to enable future calculations through presentation of a mathematical diagram.</p> <p>2 marks for recognising the use of Pythagoras' theorem to substitute in and calculate the distance of the pneumatic cylinder from pivot to open.</p> <p>1 mark for calculating the cylinder stroke.</p> <p>*Allow error carried forward (ECF) where correct working out is shown.</p> <p>Working out must be shown in order to award appropriate marks.</p>

Question			Answer	Marks	Guidance
4	(c)	(i)	<p>Interface component:</p> <p>solenoid valve (✓)</p> <p>Other possible responses include:</p> <ul style="list-style-type: none"> • Electrically-operated valve • Solenoid 3/2 valve • Electromagnetic valve 	<p>1</p> <p>AO4 1c</p>	<p>1 mark for identifying and appropriate interface component.</p> <p>Allow the mark for identifying a valve which is controlled by an electric signal.</p>
4	(c)	(ii)	<p>Example answer:</p> <p>The diagram should show clear evidence of:</p> <ul style="list-style-type: none"> A) solenoid valve to control air to the two ends of the cylinder. This would be a 5/2 valve for a double acting cylinder B) The air supply and exhausts should be shown C) A current driver between the computer output port and the solenoid valve. This might also be named as a MOSFET, darlington or relay D) The power supply for the solenoid valve should be shown interconnected with the driver and the solenoid valve. <p>Award credit for any other appropriate response</p>	<p>4</p> <p>AO4 1c</p>	<p>1 mark for correctly showing the interface component on the circuit diagram.</p> <p>1 mark for correctly showing the air supplier and exhausts on the circuit diagram.</p> <p>1 mark for correctly showing the current driver on the circuit diagram.</p> <p>1 mark for correctly showing the power supply on the circuit diagram, interconnected with the driver and the solenoid valve.</p> <p>Enough information should be given to allow a third party to fully interface the pneumatic cylinder to the programmable controller.</p> <p>Candidates can draw on practical experience from their own product analysis to support their response to this question.</p>

Question			Answer	Marks	Guidance	
					Content	Levels of response
4	(d)	*	<p>Indicative content:</p> <ul style="list-style-type: none"> Rigorous, recurring and progressive testing, modelling and development, with user feedback' of prototype solutions helps to achieve the fit for purpose outcome. The design would be modelled in a development area, using the actual valve and cylinder components to test that the air pressures and forces generated are sufficient to overcome friction and operate the valve. This will identify any required modifications to improve the design solution. User testing and location testing can be used at throughout the process to obtain feedback that identifies where the user foresees issues with the system. This will lead into consideration of modifications in line with stakeholder requirements. CAD could be used to model the entire system before manufacture of parts or assembly of system components. This allows clearances to be checked and distances to be finalised before final fitting on site. The modelled system can be soak tested, i.e. continually cycled for several thousand operations to generate a rough idea of system life expectancy. The outcomes from this testing can be analysed to identify areas of improvement that need to be made in future iterations of the product development. 	<p>8</p> <p>AO3 2 x 2a 3 x 2b</p> <p>AO4 3 x 2c</p>	<p>Examples of how iterative design processes would apply, must be in relation to supporting the design and manufacture of the laundry water tank.</p>	<p>Level 3 (6–8 marks)</p> <p>The candidate produces a thorough discussion of the ways in which iterative design processes can ensure a design solutions for the laundry water tank are fit for purpose. The candidate shows a mature understanding and analysis of the wider issues in the question, considering reflections through exploring, creating and evaluating in an ongoing process. This creates a discussion that is both cohesive and well considered.</p> <p>There is a well-developed line of reasoning which is clear and logically structured. The information presented is relevant and substantiated with the use of examples.</p> <p>Level 2 (3–5 marks)</p> <p>The candidate produces a sound discussion of the ways in which iterative design processes can ensure a design solutions for the laundry water tank are fit for purpose. The candidate shows a reasonable understanding and analysis of the wider issues in the question, considering reflections</p>
					<p>Candidates can draw on practical experience from their own undertaking of iterative design processes to support their response to this question.</p> <hr/> <p>A candidate operating at Level 3 would be expected to access all of the AO4 (2c) marks and the majority of the AO3 (2a/2b) marks.</p> <p>A candidate operating at Level 2 would be expected to access at least two of the AO4 (2c) marks and at least one of the AO3 (2a) marks.</p> <p>A candidate operating at Level 1 would only be expected to access the AO4 (2c) marks.</p>	

Question	Answer	Marks	Guidance
	<ul style="list-style-type: none"> The software for the controller can be developed, debugged and tested with the user before installing into the laundry system. User feedback can be very useful for further developing the solution. <p>Award credit for any other appropriate response</p>		<p>through exploring, creating and evaluating in an ongoing process. This creates a discussion that is for the most part cohesive and well considered.</p> <p>There is a line of reasoning presented with some structure. The information presented is in the most-part relevant and supported by some evidence.</p> <p>Level 1 (1–2 marks)</p> <p>The candidate demonstrates a basic knowledge of the ways in which iterative design processes can ensure a design solutions for the laundry water tank are fit for purpose. Any understanding is limited with little consideration of the wider issues in the question. There is no analysis or evaluation.</p> <p>The information has some relevance and is presented with limited structure or detail The information is supported by limited evidence.</p> <p>Level 0 (0 marks)</p> <p>No response or no response worthy of credit.</p>

Question			Answer	Marks	Guidance	
5	(a)		<p>Reasons why design engineers would consider environmental impact, e.g.:</p> <p>The choice of whether to use raw resources to manufacture parts or use recycled or reused material (✓). There is always an option to use recycled pellets in a thermopolymer product the for instance – this option would not be available if a thermosetting polymer was chosen (✓)</p> <p>In order to minimise the amount of material used, the design engineer may consider the quantity of material used to manufacture parts, reducing quantities where possible (✓). This will result in less material taken from their source, particularly when from a non-renewable source (✓).</p> <p>Other possible environmental impact considerations during manufacture could be:</p> <ul style="list-style-type: none"> the choice of a manufacturing system/company with a low carbon footprint and/or low pollutant emissions which might attract a financial bonus linked with an environmental incentive end of life considerations - designing the product to be manufactured in a way which makes it easily separable into component parts for recycling at end of product life. This is attractive to stakeholders and may attract financial incentives <p>Award credit for any other appropriate response</p>	<p>4</p> <p>AO4 2 x 2a 2 x 2b</p>	<p>1 mark for each of two reasons why design engineers consider the environmental impact during product manufacture.</p> <p>1 mark for explaining the reasons.</p>	
Question			Answer	Marks	Guidance	
					Content	Levels of response
5	(b)	*	<p>Indicative content:</p> <ul style="list-style-type: none"> The initial growth in popularity will be linked to the initial demand for the product. The inclusion of special features or USPs may promote the initial popularity. The rate of growth will be limited if demand exceeds supply, which could occur if the manufacturing rate is too 	<p>8</p> <p>AO3 2 x 2a 3 x 2b</p> <p>AO4 1 x 2a 2 x 2b</p>	<p>Examples used must be of products or situations that demonstrate a stakeholder's interest in sustainable products.</p> <hr/> <p>A candidate operating at Level 3 would be expected to access all of the AO4 (2a/2b) marks and the</p>	<p>Level 3 (6–8 marks)</p> <p>The candidate produces a thorough discussion of the reasons why stakeholders would have an interest in the sustainability of a product. The candidate shows a mature understanding and analysis of the wider issues in the question</p>

Question	Answer	Marks	Guidance
	<p>low or if insufficient stock is generated before product release.</p> <ul style="list-style-type: none"> • Rate of growth will also be affected by advertising methods and by brand image. • Sustaining a product's popularity will be linked with customer's reaction to the quality of the products when they are first released. Customers leaving good product reviews on e-commerce websites will inevitably promote ongoing sales, and vice versa. • Maintaining popularity may be linked with fashion, especially if the product's design is linked with a trend or a modern technology, e.g. there was a trend for wind-up torches a few years ago which has waned in recent times. • Eventual product decline will be linked with the product's technology becoming obsolete, e.g. lighting products with incandescent bulbs are rarely sold now because low energy LED bulbs mean that batteries last longer, and a brighter light is produced. Fashion, cost and product reputation will all play a part. • Stakeholders have an interest in some products due to the knowledge that the materials and processes used have consideration of fairtrade, or come from reliable managed natural sources. <p>Award credit for any other appropriate response</p>	<p>majority of the AO3 (2a/2b) marks.</p> <p>A candidate operating at Level 2 would be expected to access at least two of the AO4 (2a/2b) marks and at least one of the AO3 (2a) marks.</p> <p>A candidate operating at Level 1 would be expected to access the AO4 (2a) mark and one of the AO4 (2b) marks.</p>	<p>through the use of examples and their discussion is more cohesive and well considered as a result.</p> <p>There is a well-developed line of reasoning which is clear and logically structured. The information presented is relevant and substantiated with the use of examples.</p> <p>Level 2 (3–5 marks)</p> <p>The candidate produces a sound discussion of the reasons why stakeholders would have an interest in the sustainability of a product. The candidate shows a reasonable understanding and analysis of the wider issues in the question through the use of examples and their discussion is for the most part well-structured and considered.</p> <p>There is a line of reasoning presented with some structure. The information presented is in the most-part relevant and supported by some evidence.</p> <p>Level 1 (1–2 marks)</p> <p>The candidate demonstrates only knowledge of the reasons why</p>

Question			Answer		Marks	Guidance
						<p>stakeholders would have an interest in the sustainability of a product. Any understanding is limited with little consideration given to wider environmental issues. There is no analysis or evaluation.</p> <p>The information has some relevance and is presented with limited structure or detail The information is supported by limited evidence.</p> <p>Level 0 (0 marks) No response or no response worthy of credit.</p>

Assessment Objectives (AO) grid

Question	AO3	AO4
1a	1	1
1b(i)	2	
1b(ii)		3
1c		4
1d(i)		2
1d(ii)		4
1e	2	4
2a(i)	1	1
2a(ii)	1	2
2b		2
2c(i)		3
2c(ii)		2
3a		4
3b		2
3c		4
3d		5
4a(i)	1	3
4a(ii)		4
4b(i)	1	1
4b(ii)	2	3
4c(i)		1
4c(ii)	1	3
4d*	5	3
5a		4
5b*	5	3
Total	22	68
Overall Total		90

BLANK PAGE