

**AS Level in Design and Technology:
Product Design (H006/01)
Principles of Product Design
Sample Question Paper**

Version 3.4

Date – Morning/Afternoon

Time allowed: 1 hour 45 minutes

You may use:

- a scientific calculator
- a ruler
- geometrical instruments
- pencils/pens



First name										
Last name										
Centre number						Candidate number				

INSTRUCTIONS

- Use black ink. HB pencil may be used for graphs and diagrams only.
- Complete the boxes above with your name, centre number and candidate number.
- Answer **all** the questions.
- Write your answer to each question in the space provided. Additional paper may be used if necessary, but you must clearly show your candidate number, centre number and question number(s).
- Where appropriate, your answers should be supported with working. Marks may be given for a correct method even if the answer is incorrect.
- Do **not** write in the bar codes.

INFORMATION

- The total mark for this paper is **90**.
- The marks for each question are shown in brackets [].
- Quality of extended responses will be assessed in questions marked with an asterisk (*).
- This document consists of **20** pages

1 **Fig.1** shows a baby feeding set that includes a bowl and spoon.

(Image of a baby feeding set redacted due third party copyright restrictions)

Fig.1

(a) Analyse the feeding set to identify how **three** design features meet the needs of the intended user(s).

1.....
.....
2.....
.....
3.....
.....[3]

(b) The feeding set is manufactured from polypropylene.

Explain how **two** properties of polypropylene make it a suitable material for the feeding set.

1.....
.....
.....
2.....
.....
.....[4]

(c) Injection moulding has been used to form the parts of the feeding set.

Explain **two** reasons why injection moulding is suitable for forming parts of the feeding set.

1.....
.....
.....
2.....
.....
.....[4]

(d) The polymer used to make the spoon in the feeding set incorporates a smart material.

Name **one** smart material that could be used and describe how it would function.

.....
.....
.....
.....[2]

2 **Table 1** shows anthropometric data in relation to seating positions.

Fig. 2 and **Fig. 3** show anthropometric manikins.

Dimensions (mm)		Age Range 19–65					
		Men (Percentiles)			Women (Percentiles)		
		5%	50%	95%	5%	50%	95%
1	Sitting height	860	915	970	800	855	910
2	Sitting eye height	740	800	860	700	750	800
3	Sitting shoulder	570	615	660	530	580	630
4	Sitting elbow height	210	250	290	190	235	280
5	Thigh thickness	130	155	180	120	150	180
6	Popliteal height (lower leg length)	410	450	490	370	410	450
7	Knee height	490	535	580	460	495	530
8	Buttock-popliteal length	450	510	570	440	500	560
9	Buttock-knee length	560	605	670	520	585	650
10	Abdominal depth	220	275	330	200	270	340
11	Chest depth	210	245	280	210	250	290

Table 1

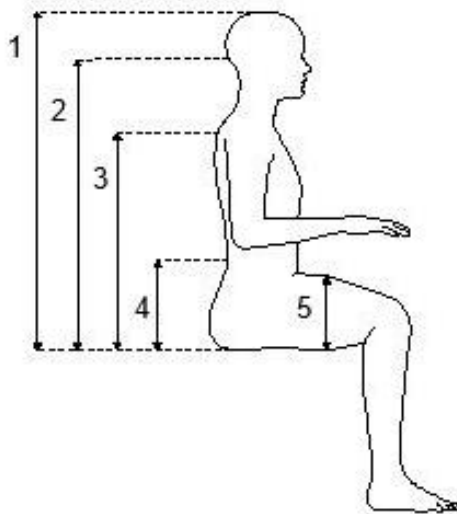

Fig 2

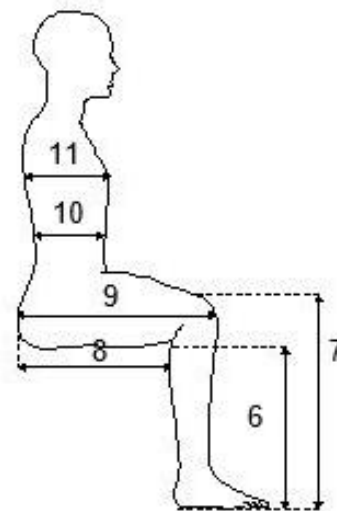

Fig. 3

- (a) Within an office, the chairs used have a fixed seat height of 450 mm above the ground. The top of the desks for people to rest their arms on is 690 mm above the ground.

Using the measurements given, calculate an approximate percentage of the adult population for which the desk and chair combination are suitable. There are an equal number of men and women.

Analyse the posture of the manikin in **Fig. 2** and use information from **Table 1** and **Fig. 3** when answering this question. You **must** show your working out.

Approximate percentage = % **[6]**

(b) Fig. 4 shows an adjustable office chair.

(Image of an adjustable office chair redacted due third party copyright restrictions)

Fig. 4

The office manager has decided to buy adjustable chairs to improve the comfort of the 38 members of staff when working at their desks.

Two suppliers have been approached to offer prices. Supplier A quotes a fixed price of £42.75 per chair. Supplier B quotes a price of £53.97, but offers a 20% discount when ordering more than 30 chairs.

Calculate which supplier is offering the best price and by how much.

Supplier by £ [2]

- (c)** A Polyester knitted textile has been used for the seat and back of the office chair shown in **Fig. 4**.

Explain **two** reasons why the polyester knitted textile would be considered a suitable material for this application.

.....

.....

.....

.....

.....

.....

.....

.....

.....

.....

[4]

- 3 **Fig.5** shows the design of a stand for a tablet computer.
Fig.6 shows side views of the two main component parts.

The body of the tablet stand will be made from 3 mm thick aluminium alloy. The hinge pin will be 15 mm in diameter.

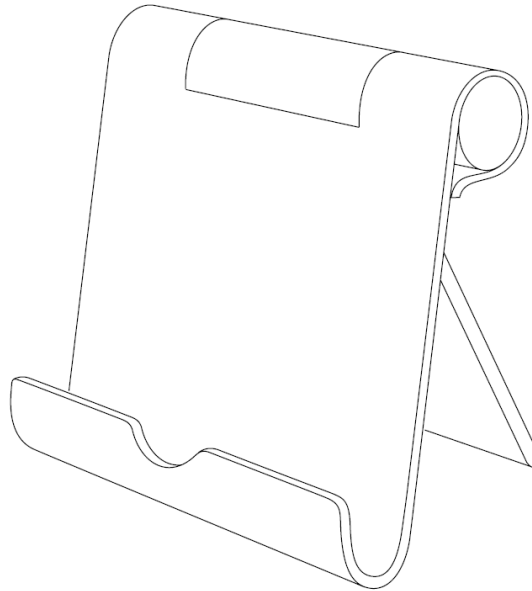

Fig.5
(not to scale)

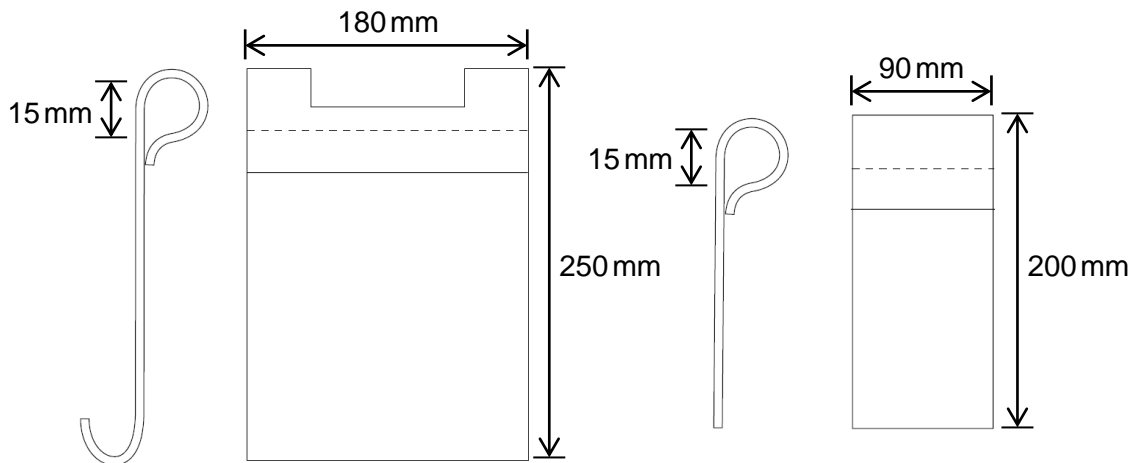

Fig.6
(not to scale)

- (a) Describe what is meant by the term 'alloy' and suggest why the aluminium used for the tablet stand has been alloyed.

.....

.....

..... [2]

- (b) A prototype of the tablet stand is to be made in a school/college workshop where aluminium alloy is not available for use.
The school workshop **does not** have CAD/CAM facilities and aluminium alloy is **not** available for use.

Use sketches and notes to describe how you would make a full size final prototype of the tablet stand in this school workshop. Give details of appropriate materials, processes, tools and any equipment required in your response. **[5]**

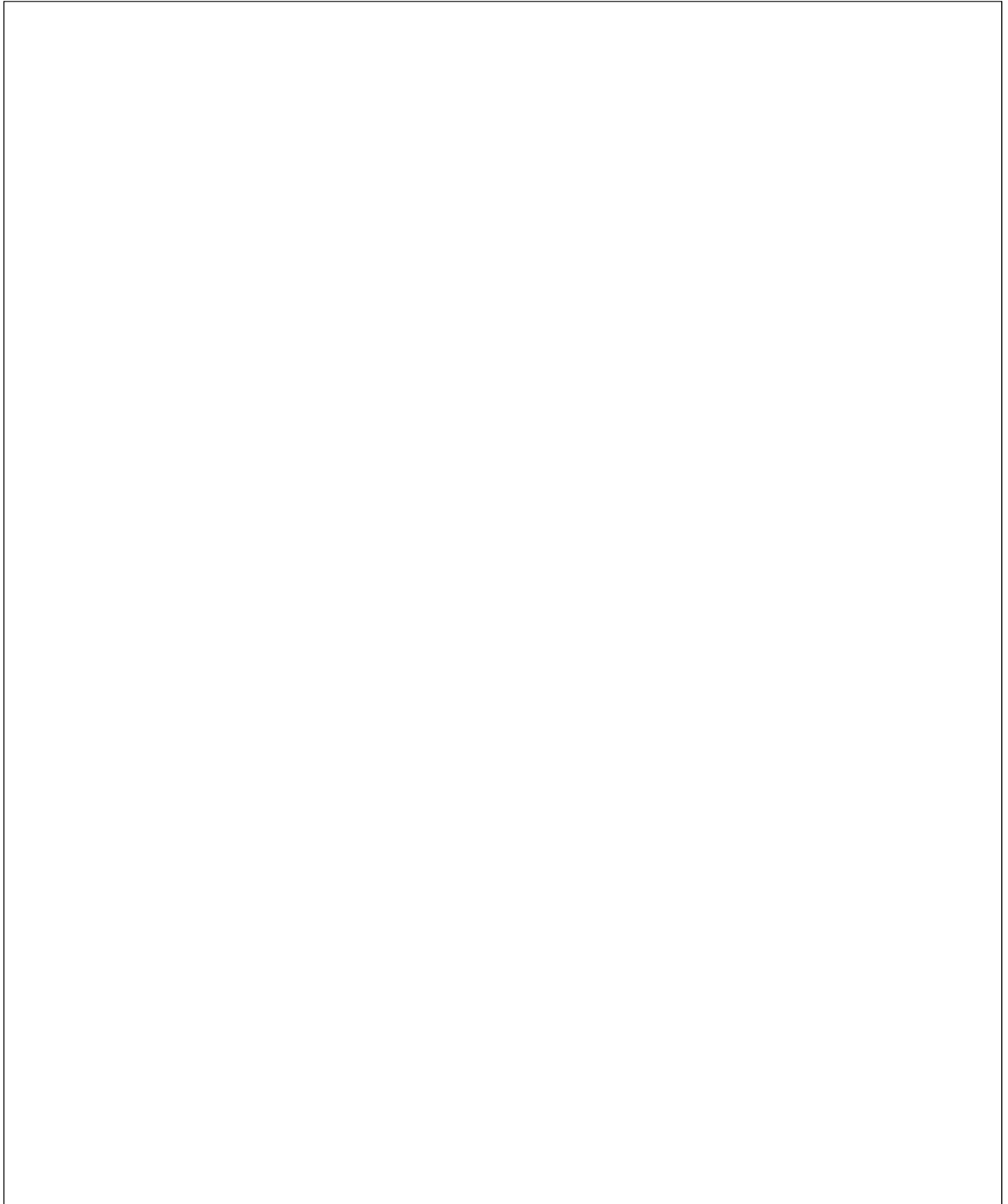

- (c) Use sketches and notes to describe how the tablet stand shown in **Fig.5** would be manufactured as a batch of 50 000 from aluminium alloy. Give details of manufacturing processes, equipment and any machinery required in your response. **[8]**

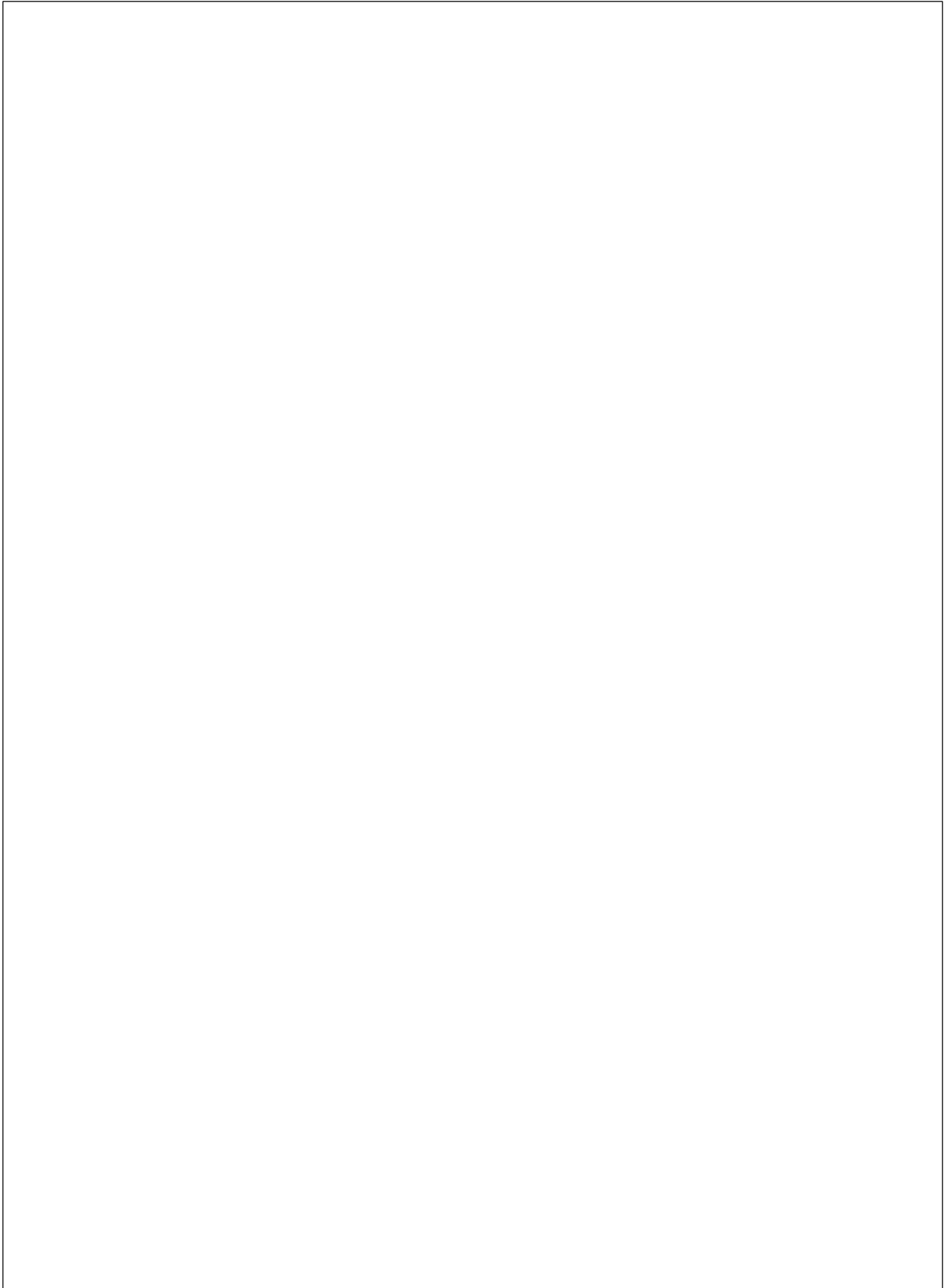

(d) Fig.7 shows a geometric design that will be engraved on the tablet stand as a company logo.

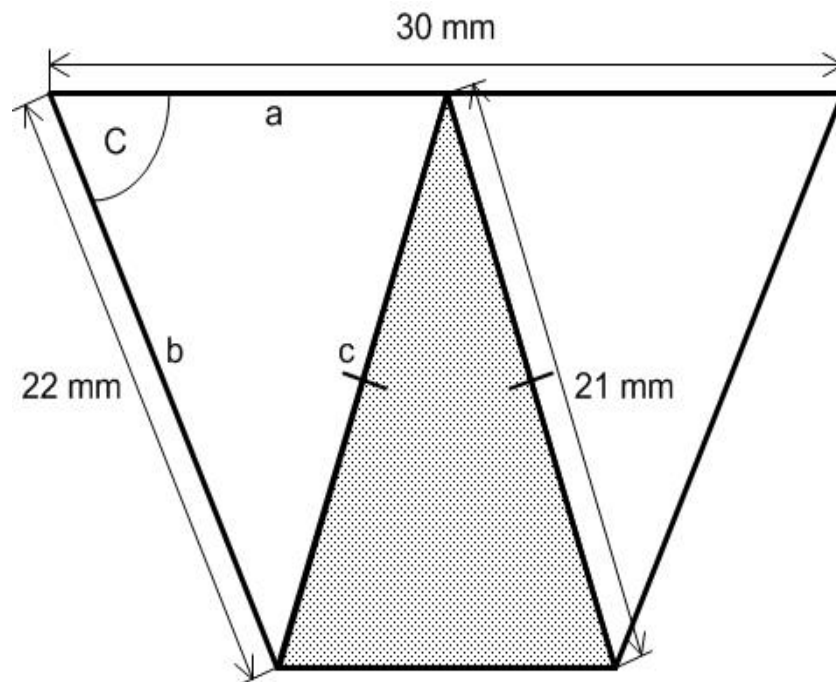

Fig.7
(not to scale)

In order to accurately mark out the design on the bookmark, the angles need to be plotted.

Calculate the Angle C.

Angle C =° [3]

- 4 **Fig.8** shows a balance bike made from birch plywood.
Fig.9 shows sectional views of the frame parts of the balance bike.

Balance bikes are used by small children to build confidence and develop their ability to balance before moving to riding a pedal bike. A balance bike must allow the user to easily touch the floor.

(Image of a balance bike redacted due third party copyright restrictions)

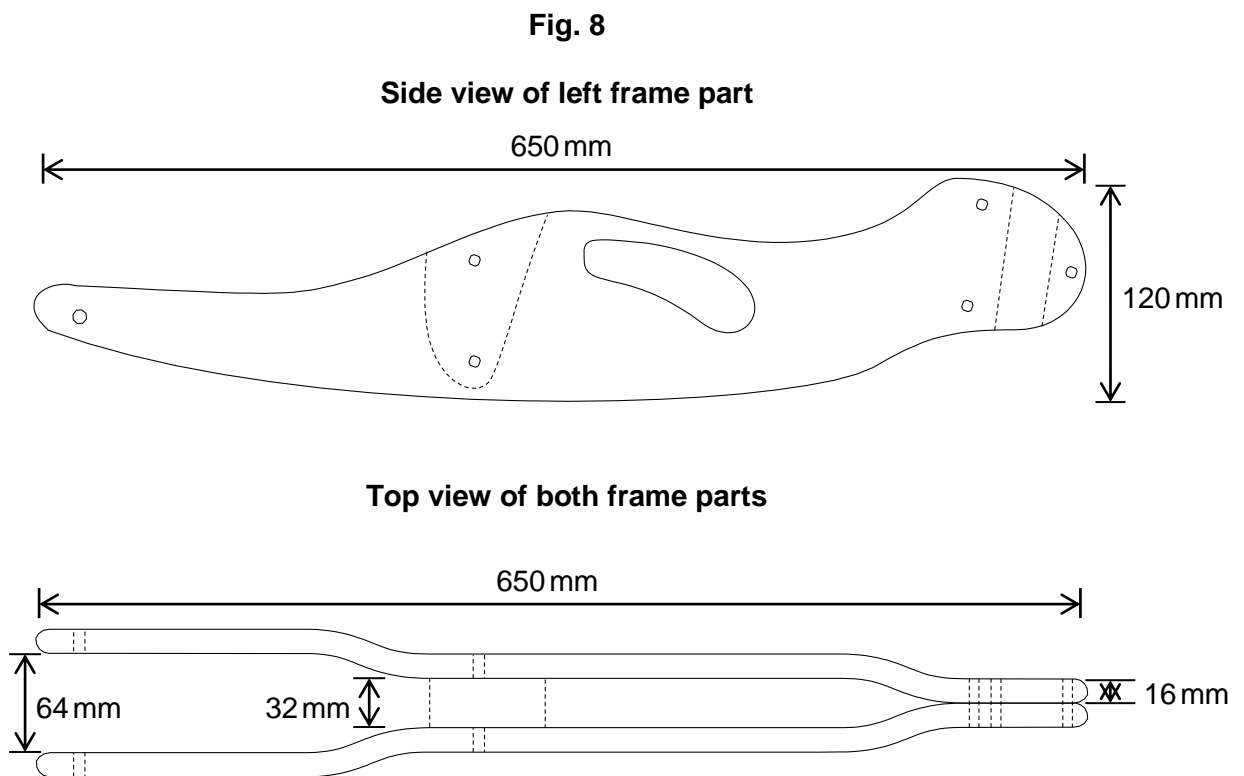

Fig. 9
(not to scale)

- (a) Describe how a component on the balance bike shown in **Fig. 8** is adjustable.

.....

.....

.....

..... [2]

(b) Parts of the balance bike are manufactured from birch plywood.

(i) Describe how the high uniform strength of birch plywood makes it a suitable material for use in the balance bike.

.....

.....

.....

..... **[2]**

(ii) Describe how the balance bike can be protected from varied weather conditions.

.....

.....

.....

..... **[2]**

(iii) The manufacturer needs to consider the thickness of the birch plywood.

Use the data provided in **Table 2** to plot out a curve graph of the data provided.

Thickness of plywood in mm	4	6.5	9	12	15	18	21	24	27	30
Compression strength in mm^2	31.8	29.3	28.6	27.7	27.4	27.2	27.0	26.9	26.8	26.7

Table 2

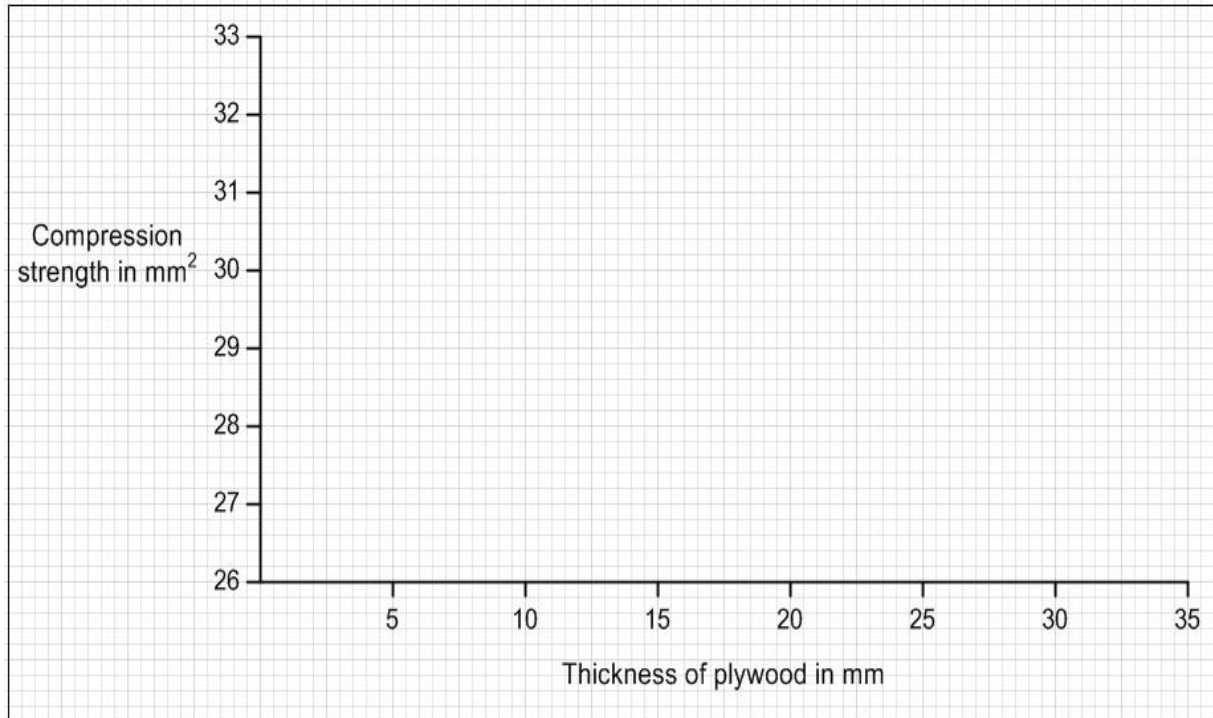

[3]

- (c) The balance bikes shown in **Fig. 8** would be made to order in small numbers. The frame parts of each balance bike must be highly accurate to ensure the product functions properly.

Using sketches and notes, describe how the method of manufacture would ensure accuracy when forming the plywood frame illustrated in **Fig. 9**. You must consider processes, equipment and any machinery required in your response.

[6]

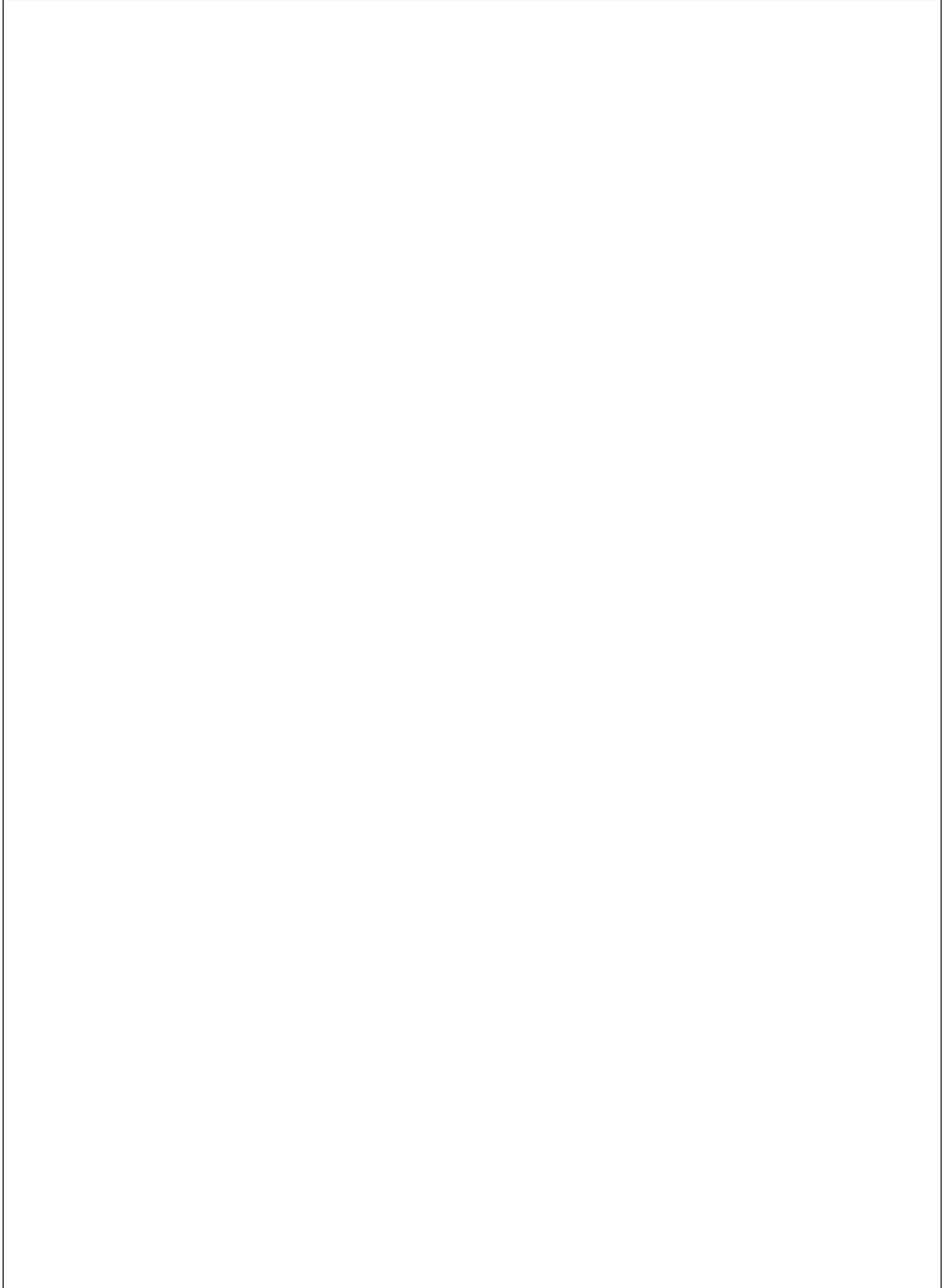

(d) The manufacturer of the balance bike has been approached by a hospital trust to consider possible adaptations to their product to support patients who need rehabilitating with their mobility skills.

(i) Give **three** justified modifications to adapt the features of the balance bike to make it suitable for these new primary users.

1.....

.....

.....

2.....

.....

.....

3.....

.....

.....[3]

(ii) Discuss the implications on the product lifecycle of the balance bike considering the modified purpose.

.....

.....

.....

.....

.....

.....

.....

.....

.....

.....

.....[6]

5 Sustainability is an important consideration in product design.

(a) Explain **one** way that design thinking has been influenced by social sustainability.

.....

.....

.....

.....

.....

.....[3]

(b) Explain **two** ways in which marketing and can impact on product sustainability.

1.....

.....

.....

2.....

.....

.....

.....[4]

Summary of updates

Date	Version	Details
April 2022	3.4	<p>Figure 1 Baby feeding set, image redacted due to third party copyright restrictions.</p> <p>Figure 4 Adjustable office chair, image redacted due to third party copyright restrictions.</p> <p>Figure 8 Balance bike, image redacted due to third party copyright restrictions.</p>

Copyright Information:

OCR is committed to seeking permission to reproduce all third-party content that it uses in the assessment materials. OCR has attempted to identify and contact all copyright holders whose work is used in this paper. To avoid the issue of disclosure of answer-related information to candidates, all copyright acknowledgements are reproduced in the OCR Copyright Acknowledgements booklet. This is produced for each series of examinations and is freely available to download from our public website (www.ocr.org.uk) after the live examination series.

If OCR has unwittingly failed to correctly acknowledge or clear any third-party content in this assessment material, OCR will be happy to correct its mistake at the earliest possible opportunity.

For queries or further information please contact the Copyright Team, The Triangle Building, Shaftesbury Road, Cambridge, CB2 8EA.

OCR is part of Cambridge University Press and Assessment, which is itself a department of the University of Cambridge.

OCR

Oxford Cambridge and RSA

...day June 20XX – Morning/Afternoon

AS Level in Design and Technology: Product Design

H006/01 Principles of Product Design

SAMPLE MARK SCHEME

Duration: 1 hour 45 minutes

MAXIMUM MARK 90



This document consists of 30 pages

PREPARATION FOR MARKING**SCORIS**

1. Make sure that you have accessed and completed the relevant training packages for on-screen marking: *scoris assessor Online Training*; *OCR Essential Guide to Marking*.
2. Make sure that you have read and understood the mark scheme and the question paper for this unit. These are posted on the RM Cambridge Assessment Support Portal <http://www.rm.com/support/ca>
3. Log-in to scoris and mark the **required number** of practice responses (“scripts”) and the **required number** of standardisation responses.

YOU MUST MARK 10 PRACTICE AND 10 STANDARDISATION RESPONSES BEFORE YOU CAN BE APPROVED TO MARK LIVE SCRIPTS.

MARKING

1. Mark strictly to the mark scheme.
2. Marks awarded must relate directly to the marking criteria.
3. The schedule of dates is very important. It is essential that you meet the scoris 50% and 100% (traditional 50% Batch 1 and 100% Batch 2) deadlines. If you experience problems, you must contact your Team Leader (Supervisor) without delay.
4. If you are in any doubt about applying the mark scheme, consult your Team Leader by telephone, email or via the scoris messaging system.

5. Work crossed out:
 - a. where a candidate crosses out an answer and provides an alternative response, the crossed out response is not marked and gains no marks
 - b. if a candidate crosses out an answer to a whole question and makes no second attempt, and if the inclusion of the answer does not cause a rubric infringement, the assessor should attempt to mark the crossed out answer and award marks appropriately.
6. Always check the pages (and additional objects if present) at the end of the response in case any answers have been continued there. If the candidate has continued an answer there then add a tick to confirm that the work has been seen.
7. There is a NR (No Response) option. Award NR (No Response)
 - if there is nothing written at all in the answer space
 - OR if there is a comment which does not in any way relate to the question (e.g. 'can't do', 'don't know')
 - OR if there is a mark (e.g. a dash, a question mark) which isn't an attempt at the question.Note: Award 0 marks – for an attempt that earns no credit (including copying out the question).
8. The scoris **comments box** is used by your Team Leader to explain the marking of the practice responses. Please refer to these comments when checking your practice responses. **Do not use the comments box for any other reason.** If you have any questions or comments for your Team Leader, use the phone, the scoris messaging system, or email.
9. Assistant Examiners will send a brief report on the performance of candidates to their Team Leader (Supervisor) via email by the end of the marking period. The report should contain notes on particular strengths displayed as well as common errors or weaknesses. Constructive criticism of the question paper/mark scheme is also appreciated.

10. Annotations

Annotation	Meaning
BP	Blank page
✓	Point where mark is awarded
x	Incorrect response
L1	Level one response
L2	Level two response
L3	Level three response
ECF	Error carried forward
BOD	Benefit of doubt accepted
REP	Repetition
SEEN	Noted, but no credit given
PD	Poor diagram offering unclear response

11. Subject-specific Marking Instructions

INTRODUCTION

Your first task as an Examiner is to become thoroughly familiar with the material on which the examination depends. This material includes:

- the specification, especially the assessment objectives
- the question paper
- the mark scheme.

You should ensure that you have copies of these materials.

You should ensure also that you are familiar with the administrative procedures related to the marking process. These are set out in the OCR booklet **Instructions for Examiners**. If you are examining for the first time, please read carefully **Appendix 5 Introduction to Script Marking: Notes for New Examiners**.

Please ask for help or guidance whenever you need it. Your first point of contact is your Team Leader.

The breakdown of Assessment Objectives for AS Level in Design & Technology

	Assessment Objective
AO3	Analyse and evaluate – <ul style="list-style-type: none"> • design decisions and outcomes, including for prototypes made by themselves and others • wider issues in design and technology
AO3.1a	Analyse design decisions and outcomes, including for prototypes made by themselves and others
AO3.1b	Evaluate design decisions and outcomes, including for prototypes made by themselves and others
AO3.2a	Analyse wider issues in design and technology
AO3.2b	Evaluate wider issues in design and technology
AO4	Demonstrate and apply knowledge and understanding of – <ul style="list-style-type: none"> • technical principles • design and making principles
AO4.1a	Demonstrate knowledge of technical principles
AO4.1b	Demonstrate understanding of technical principles
AO4.1c	Apply knowledge and understanding of technical principles
AO4.2a	Demonstrate knowledge of design and making principles
AO4.2b	Demonstrate understanding of design and making principles
AO4.2c	Apply knowledge and understanding of design and making principles

Question		Answer	Marks	Guidance
1	(a)	<p>From having analysed the product, e.g.:</p> <p>Bowl has textured handle so easy for baby/parent to hold/grip (✓)</p> <p>Set has secure lid so can be used when travelling / to store food in airtight/leak-proof way (✓)</p> <p>Spoon designed to clip into the lid so secure when travelling (✓)</p> <p>Other responses could include:</p> <ul style="list-style-type: none"> • Hinged cover over spoon end keeps spoon clean / hygienic for the baby • Moulded feet on the bowl allow stability when feeding / harder for baby to push/knock over • Moulded tabs on the lid will allow the parent to open the bowl with ease • Spoon has wide and rounded handle to enable baby to grip <p>Award credit for any other appropriate response</p>	<p>3</p> <p>A03</p> <p>1a</p>	<p>1 mark for each of three justified design features</p> <p>Do not credit if a candidate identifies a feature but does not explain how this feature meets user needs.</p> <p>Candidates can draw on practical experience from product analysis to support their response to this question.</p>

1	(b)	<p>Explained properties of polypropylene, e.g.:</p> <p>Food-safe polymer (✓) meaning that the food will not be affected by any chemicals/taste/odours from the plastic. (✓)</p> <p>Chemically inert material. (✓) The polymer will not be stained by baby soups and meals. (✓)</p> <p>Other examples could include:</p> <ul style="list-style-type: none"> • Good heat and steam resistance therefore ideal for use in microwave ovens to heat baby food. • Good chemical resistance so will not degrade from frequent washing/disinfecting the bowl and spoon. • Good impact resistance so will sustain knocks/tumbles from baby dropping it. <p>Award credit for any other appropriate response</p>	<p>4</p> <p>AO4</p> <p>1c</p>	<p>1 mark for each of two properties. 1 mark for explanation of each property.</p> <p>Specific reference to suitability for the feeding set is needed for the marks.</p>
1	(c)	<p>Reasons why injection moulding is suitable for the feeding set, e.g.:</p> <p>Parts of the set have interlocking complex shapes such as the hinged spoon cover / airtight bowl lid (✓) which can be achieved with a complex mould without additional finishing/joining methods. (✓)</p> <p>The set requires textured features such as the grip on the bowl handle (✓) which can be achieved by integrating into the moulding without any additional processes. (✓)</p> <p>Other examples could include:</p> <ul style="list-style-type: none"> • Likely that the feeding set will be required in high volumes so this can be achieved with consistent high quality. 	<p>4</p> <p>AO4</p> <p>1c</p>	<p>1 mark for each of two examples of injection moulding. 1 mark for explanation of suitability.</p> <p>Specific reference to suitability for the feeding set is needed for the marks.</p>

		<ul style="list-style-type: none"> High level of precision so that spoon clips in position, the cover over the spoon clips and hinges smoothly. <p>Award credit for any other appropriate response</p>		
1	(d)	Thermochromic pigments (✓) could be added to the polymer for the spoon. This will change colour in response to heat to indicate to the user that the baby food is too hot/unsafe for them to eat. (✓)	<p>2</p> <p>AO4</p> <p>2 x 1c</p>	<p>1 mark for identifying the smart material.</p> <p>1 mark for describing the function within the product.</p> <p>Specific reference to suitability for the feeding set is needed for the marks.</p> <p>Thermochromic pigments is the only valid answer.</p>
1	(e)*	<p>Indicative content:</p> <p>In recent years, there have been significant developments in applications of intelligent, or 'smart', materials. These can be defined as materials with one or more properties (e.g. mechanical, thermal, optical, or electromagnetic properties) that can be varied in a predictable or controllable way in response to external stimuli, such as, for example, stress, temperature, moisture. Such materials are now used in wide range of applications, from photochromic lenses for sunglasses to military and aerospace uses.</p> <p>Implications to product designers could include: opens up a wider range of product opportunities with increased functionality of the material. Smart materials are associated with modern, 21st century fashion and would be desirable and commercially popular. Significant opportunities in medical and health and safety products.</p> <p>Implications to manufacturers could be that they must keep up to date with availability, range and scope of developing smart materials. Most do not require additional processing procedures, they can be easily introduced to existing</p>	<p>8</p> <p>AO3</p> <p>4 x 2b</p> <p>AO4</p> <p>2 x 1c</p> <p>AO4</p> <p>2 x 2c</p>	<p>Level 3 (6–8 marks)</p> <p>The candidate produces a thorough discussion of the implications of the rapidly increasing development and availability of smart materials to product designers and manufacturers.</p> <p>The candidate shows a mature understanding and analysis of the wider issues in the question and their discussion is more cohesive and well considered as a result.</p> <p>There is a well-developed line of reasoning which is clear and logically structured. The information</p> <p>Do not accept implications focused on the consumer, the community, or to the environment. Do not accept vague references to better, newer products.</p> <p>As a guide for full marks there will be two or three different examples or products discussed and candidates should include the implications both to the product designer and the manufacturer.</p> <p>_____</p> <p>A candidate operating at Level 3 would be expected to access the AO4 (1c)</p>

		<p>manufacturing systems. Research and development key departments in modern manufacturing or access to research information.</p> <p>Explanation/justification could be in the form of: So that the manufacturer can get high quality, high tech, innovative products to the market before competition result in higher sales, higher profile. Product designers keep aware of trends, opportunities, e.g. wearable tech, medical support, high tech must have domestic products</p> <p>Great publicity for designer/manufacturer for advanced creative products using space age technology materials.</p> <p>Draw backs, some products will be more expensive, but generally not significant considering product improvement. Keeping up with developments can be expensive and sometimes risky due to rapidly changing materials, new and better just around the corner – some may quickly lose their popularity – thermos-chromic mugs.</p> <p>Examples could include:</p> <ul style="list-style-type: none"> • Medical applications having great impact, Shape memory alloys used in cardiovascular procedures, • Smart bandages use thermochromic materials to monitor wound healing. • SMAs used increasingly in car and aeronautical industry for quick action locking/latching devices • Piezoelectric materials used in high tech or miniaturised speakers • Smart coatings – self-cleaning glass etc • Photochromic materials used in spectacle lenses and in building design, sheets of glass coated with photochromic material can react to light conditions to keep occupants comfortable 		<p>marks, the AO4 (2c) marks, and the majority of the AO3 (2b) marks.</p> <p>A candidate operating at Level 2 would be expected to access most of the AO4 (1c) / AO4 (2c) marks, and at least two of AO3 (2b) marks.</p> <p>A candidate operating at Level 1 would be expected to access AO4 (1c) / AO4 (2c) marks.</p>	<p>presented is relevant and substantiated with the use of examples.</p> <p>Level 2 (3–5 marks)</p> <p>The candidate produces a sound discussion of the implications of the rapidly increasing development and availability of smart materials to product designers and manufacturers The candidate shows a reasonable understanding and analysis of the wider issues in the question and their discussion is for the most part well-structured and considered.</p> <p>There is a line of reasoning presented with some structure. The information presented is in the most-part relevant and supported by some evidence.</p> <p>Level 1 (1–2 marks)</p> <p>The candidate demonstrates knowledge of the implications of the rapidly increasing development and availability of smart</p>
--	--	--	--	---	--

			<p>Award credit for any other appropriate response</p>			<p>materials to product designers and manufacturers Any understanding is limited with little consideration given to wider environmental issues. There is no analysis or evaluation.</p> <p>The information has some relevance and is presented with limited structure or detail The information is supported by limited evidence.</p> <p>Level 0 (0 marks) No response or no response worthy of credit.</p>
--	--	--	---	--	--	--

Question		Answer	Marks	Guidance																																										
2	(a)	<table border="1"> <thead> <tr> <th colspan="3">Men</th> <th colspan="3">Women</th> </tr> <tr> <th>5%</th> <th>50%</th> <th>95%</th> <th>5%</th> <th>50%</th> <th>95%</th> </tr> </thead> <tbody> <tr> <td>450</td> <td>450</td> <td>450</td> <td>450</td> <td>450</td> <td>450</td> </tr> <tr> <td>+</td> <td>+</td> <td>+</td> <td>+</td> <td>+</td> <td>+</td> </tr> <tr> <td>210</td> <td>250</td> <td>290</td> <td>190</td> <td>235</td> <td>280</td> </tr> <tr> <td>=</td> <td>=</td> <td>=</td> <td>=</td> <td>=</td> <td>=</td> </tr> <tr> <td>660</td> <td>700</td> <td>740</td> <td>640</td> <td>685</td> <td>730</td> </tr> </tbody> </table> <p>(✓)(✓)</p> <p>Men = 690 is 10 less than 50% Women = 690 is 5 more than 50% (✓)</p> <p>Men = $700 - 660 = 40 \div 10^* = 4$, $50\% - 5\% = 45\% \div 4 = 11.25\%$, $50\% - 11.25\% = 38.75\%$ percentile (✓)</p> <p>Women = $730 - 685 = 45 \div 5^* = 9$, $95\% - 50\% = 45\% \div 9 = 5\%$, $50\% + 5\% = 55\%$ percentile (✓)</p> <p>$38.75\% + 55\% = 93.75\% \div 2 = 46.86\%$, $100\% - 46.86\% = 53.13\%$ (✓)</p> <p>Award credit for any other appropriate method of calculation</p>	Men			Women			5%	50%	95%	5%	50%	95%	450	450	450	450	450	450	+	+	+	+	+	+	210	250	290	190	235	280	=	=	=	=	=	=	660	700	740	640	685	730	<p>6</p> <p>AO3 2 x 1a</p> <p>AO4 4 x 1c</p>	<p>1 mark for identifying the sitting elbow height from analysing data in the table.</p> <p>1 mark for combining the seat height and the elbow height</p> <p>1 mark for identifying where the combined seat and elbow height fits within the percentile ranges from analysing data in the table.</p> <p>1 mark for calculating the approximate percentile location and value for men.</p> <p>1 mark for calculating the approximate percentile location and value for women.</p> <p>1 mark for combining and correctly calculating the approximate percentage of people that the desk is suitable for.</p> <p>*Allow error carried forward (ECF) where correct working out is shown.</p> <p>Working out must be shown in order to award appropriate marks.</p>
Men			Women																																											
5%	50%	95%	5%	50%	95%																																									
450	450	450	450	450	450																																									
+	+	+	+	+	+																																									
210	250	290	190	235	280																																									
=	=	=	=	=	=																																									
660	700	740	640	685	730																																									
2	(b)	<p>Supplier A = $\pounds 42.75 \times 38 = \pounds 1,624.50$, Supplier B = $((\pounds 53.97 \times 38) = \pounds 2,050.86) \times 20\% = \pounds 1,640.69$ (✓)</p> <p>$\pounds 1,624.50^* - \pounds 1,640.69^* = \pounds 16.19$ Supplier A by $\pounds 16.19$ (✓)</p>	<p>2</p> <p>AO4 2c</p>	<p>1 mark for correctly calculating the cost of both suppliers</p> <p>1 mark for deducting the cheapest and the cost difference between them.</p> <p>*Allow error carried forward (ECF) where correct working out is shown.</p> <p>Correct answer scores full marks.</p>																																										

2	(c)	<p>Polyester knitted textile properties that make them suitable for office chair:</p> <p>The polyester used in the textile is stain resistance (tea/coffee/ink stain) (✓) will add durability in a frequently used office chair. (✓)</p> <p>The knitted construction of the material allows for greater movement (✓) therefore, making it more comfortable for the user to sit on. (✓)</p> <p>Other examples include:</p> <ul style="list-style-type: none"> • High energy absorption, material will not break, split from extreme use - very high abrasion resistance. • Resistant to stretching and shrinking – will keep shape when stretched over chair. • Easily washed should accidents occur or through extensive use. <p>Award credit for any other appropriate response</p>	<p>4</p> <p>AO3 2 x 1b</p> <p>AO4 2 x 1c</p>	<p>1 mark for each of two points that demonstrate suitability of the polyester knitted textile. 1 mark for valid justification for each point.</p> <p>Specific reference to suitability for the office chair is needed for the marks.</p>
---	-----	--	---	---

Question		Answer	Marks	Guidance	
3	(a)	<p>An alloy is a metal compound produced by combining a metal with one or more other elements. (✓) Aluminium is quite weak so alloying will make the tablet stand stronger and less likely to bend or break. (✓)</p> <p>Other examples include:</p> <ul style="list-style-type: none"> Pure aluminium is quite soft so alloying will make the tablet stand harder and less likely to be scratched, dented or marked. <p>Award credit for any other appropriate response</p>	<p>2</p> <p>AO4 1 x 1a</p> <p>AO4 1 x 1c</p>	<p>1 mark for description of an alloy</p> <p>1 mark for reasoning for why an alloy is used in relation to the tablet stand.</p>	
3	(b)	<p>Indicative content:</p> <p>Material: 3mm acrylic</p> <p>Process could be:</p> <ul style="list-style-type: none"> Mark out the design for the stand pieces on 3mm acrylic (with sketches of the two pieces as nets) Use a band saw and/or scroll saw to cut out the two acrylic pieces using a rear fence to ensure straight edges where required. Prepare two 15mm diameter cylinders of timber or metal to use as a forming mould for the top and bottom turns. Make sure they're cut at least 60mm longer so they can be gripped when forming and mark out 180mm and 90mm in the centre to line the component parts up with. Mark a line across its length of the bottom rod to ensure accuracy when moulding the acrylic. Mark the top of the main acrylic piece to know where to align the turn to when forming it over the top rod. Place the acrylic pieces in an oven set at 180°C one at 	<p>5</p> <p>AO4 1c</p>	<p>Content</p> <p>All processes demonstrated in the candidate's response must be in relation to the tablet stand and have full consideration of the material being an appropriate alternative to 3mm aluminium alloy.</p> <p>All processes outlined should be appropriate for a school/college workshop.</p> <p>Candidates can draw on practical experience from the workshop to support their response to this question.</p>	<p>Levels of response</p> <p>Level 3 (4–5 marks)</p> <p>The candidate will demonstrate a thorough knowledge of the process, applying this knowledge to how the tablet stand would be made in a school workshop, with accurate technical terms and detailed consideration of any appropriate materials tools and equipment required. Sketches used will be clear and supported with relevant notes.</p> <p>Level 2 (2–3 marks)</p> <p>The candidate will</p>

		<p>a time to prepare it for thermoforming.</p> <ul style="list-style-type: none"> • Once the acrylic is sufficiently pliable, remove it from the oven with gloves and quickly align the rod moulds in position at both ends, thermoforming the acrylic round them in to position, using a wooden block to ensure the acrylic follows the mould. • Repeat with the rear support piece of acrylic. • Cut a piece of 15mm diameter acrylic rod to 180mm, sand and polish both ends and then insert this through the top folds of both acrylic pieces to create a hinge. <p>The processes outlined must be appropriate to the polymer material being used.</p> <p>Award credit for any other appropriate response</p>		<p>Maximum of Level 2 can be achieved if no sketches are given in support of description notes.</p>	<p>demonstrate a sound knowledge of some aspects of the process, applying this knowledge to how the tablet stand would be made in a school workshop, with reasonable use of technical terms and consideration of any appropriate materials, tools and equipment required. Sketches used will be for the most part clear and supported with notes most of which are relevant, or may not exist where descriptions are more detailed.</p> <p>Level 1 (1 mark)</p> <p>The candidate will demonstrate a limited knowledge of the process, applying this knowledge in a basic way to how the tablet stand would be made in a school workshop, with a limited use of technical terms and basic consideration of any appropriate materials, tools and/or equipment required. Sketches and/or notes will be unclear.</p> <p>Level 0 (0 marks)</p>
--	--	---	--	---	---

					No response or no response worthy of credit.
3	(c)	<p>Responses may be presented in various ways, but is likely to incorporate the following indicative content:</p> <p>Manufacturing process could be:</p> <ul style="list-style-type: none"> Aluminium alloy plate (usually on a roll) feed into stamping/blanking press. (could also be an extrusion) Very high quality/accurate dies required. (illustration of a die with the tablet stand design / shape of the net) Bottom die fixed on bolster plate, top die attached to ram. Press may be mechanical or hydraulic. Stamping lubricant applied. Guards in place. First stamp, cut pieces drop, ram rises. Each piece moves on a conveyor belt to a second ram bed where the bottom curve is formed between a bending die and two pressure dies. (illustration should be shown) The pieces move along onto a third cycle where the hinge section is formed through three-roll bending, (illustration of aluminium piece inside the rollers). The piece slowly moves across the power-driven rollers that move around the central roller to form a 360 degree rotation. Machine resets ready for next stamp at every stage. Quality checks taken after first few stamps and then at regular intervals on a long run to check for alignment and cutting sharpness. Sharp edges are de-burred. The anodised finish applied by electrolytic process in batches of 100 components. <p>Award credit for any other appropriate response.</p>	8 AO4 1c	Content	Levels of response
				<p>All processes demonstrated in the candidate's response must be in relation to the tablet stand and have full consideration of the industrial manufacturing processes appropriate to batch production of 50 000 items.</p>	<p>Level 3 (6–8 marks)</p> <p>The candidate will demonstrate a thorough knowledge of the process, applying this knowledge to how the tablet stand would be manufactured, with accurate technical terms and detailed consideration of any equipment and machinery required. Sketches used will be clear and supported with relevant notes.</p> <p>Level 2 (3–5 marks)</p> <p>The candidate will demonstrate a sound knowledge of some aspects of the process, applying this knowledge to how the tablet stand would be manufactured, with reasonable use of technical terms and consideration of any equipment and machinery required. Sketches used will be for the most part clear and supported with notes most of which are</p>

					relevant. Level 1 (1–2 marks) The candidate will demonstrate a limited knowledge of the process, applying this knowledge in a basic way to how the tablet stand would be manufactured, with a limited use of technical terms and basic consideration of any equipment and/or machinery required. Sketches and/or notes will be unclear. Level 0 (0 marks) No response or no response worthy of credit.
3	(d)	$30 \div 2 = 15$ (✓) $c^2 = a^2 + b^2 - 2ab \cos C$, $21^2 = 15^{2*} + 22^2 - 2(15 \times 22) \cos C$ (✓) $441 = (225 + 484 = 709) - (2 \times (330) = 660) \cos C = 66.04^\circ$ or 66° (✓)* (if incorrect formula is given in the second part, but subsequent calculation is correct)	3	1 mark for dividing the overall length of the design by 2 AO4 1c 1 mark for applying the cosine rule and substituting the numbers 1 mark for correctly solving the equation *Allow error carried forward (ECF) where correct working out is shown. Correct answer scores full marks.	

Question			Answer	Marks	Guidance
4	(a)		There are holes drilled at different heights in bike seat post. (✓) Socket/allen head bolts/screws are used to fasten and secure the seat post in to position. (✓)	2 AO4 1c	Consideration of adjusting the seat post is the only valid answer.
4	(b)	(i)	How the high uniform strength of birch plywood makes it a suitable material, e.g.: Birch has close, even grain structure, therefore gives consistent and uniform strength across the material, but particularly so when laminated with grain at right angles to form plywood. (✓) This makes it suitable for the balance bike as the bike will have to withstand forces from the weight and movement of the user. (✓) Award credit for any other appropriate response.	2 AO4 1x 1a 1x 1c	1 mark for the description of the birch plywood's uniform strength. 1 mark for describing how this makes it suitable. Specific reference to suitability for the birch plywood in relation to it being used in the balance bike is needed for the marks.
4	(b)	(ii)	How the balance bike can be protected from varied weather conditions, e.g.: A water-repellent preservative could be applied (✓) particularly protecting the edges of the birch plywood from potential rain damage. (✓) Other considerations could refer to : <ul style="list-style-type: none"> • Weather-protective stain/sealant to protect it from UV and water damage • Acrylic fabric on the cushion as this is 	2 AO4 1c	1 mark for identifying a method of protection 1 mark for describe how this method would product the bike from varying weather conditions Specific reference to suitability for the balance bike is needed for the marks.

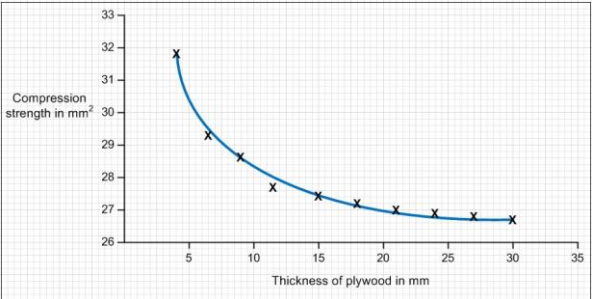
Question		Answer	Marks	Guidance	
		<p>water resistant and won't deteriorate.</p> <p>Award credit for any other appropriate response.</p>			
4	(b) (iii)		<p>3</p> <p>AO3 2 x 1a</p> <p>AO4</p>	<p>2 marks for plotting all 10 points correctly from analysing the data in Table 2.</p> <p>Or</p> <p>1 mark for plotting at least 6 points correctly from analysing the data in Table 2.</p> <p>Plus</p> <p>1 mark for drawing a curve that best fits the data.</p>	
4	(c)	<p>Indicative content:</p> <p>Process could be:</p> <ul style="list-style-type: none"> The manufacturer will be using a process of lamination. Layers of plywood (flexi-ply) will need to be glued under pressure over a former within a vacuum. The plywood could not be cut accurately until laminated together because laminates (layers of ply) would move around with the glue and under pressure. Therefore either larger pieces of ply or rectangular pieces of approximately 700 mm x 450 mm should be laminated over a former. A former will need to be built or routed that allows the curves to be formed. The former should be a high quality finish 	<p>6</p> <p>AO4 1c</p>	<p>Content</p> <p>All processes demonstrated in the candidate's response must be in relation to the frame of the balance bike and have full consideration of how to ensure accuracy. The processes, equipment and machinery used must be suitable for small scale industrial manufacture.</p> <p>Candidates can draw on practical experience from product analysis and the workshop to support their response to this question.</p>	<p>Levels of response</p> <p>Level 3 (5–6 marks)</p> <p>The candidate will demonstrate a thorough knowledge of how to ensure accuracy when forming the plywood frame of the balance bike, with accurate technical terms and detailed consideration of any processes, equipment and machinery required. Sketches used will be clear and supported with relevant notes.</p> <p>Level 2 (3–4 marks)</p> <p>The candidate will demonstrate a</p>

Question	Answer	Marks	Guidance
	<p>and sealed to prevent laminates adhering to former. (illustration of former would support this).</p> <ul style="list-style-type: none"> • 4 layers of 4mm ply/flexi-ply will be needed for each lamination. • A second mould would be required to sit the laminated rectangles or sheets of ply on for the next process. • When the lamination is complete, CAD CAM (CNC laser cutter or CNC router) could be used to cut out the shape of the frame and cut the handles. This would ensure perfectly level, clean and smooth edges around the frame and the inside of the handle. • The CAD layout would save wastage by having a separate layout for the right and left side components of the frame, meaning that 2 to 6 frame components could be made cut at the same time dependent on the bed size of the CNC machine. • Once the frame pieces have been cut, the screw holes will need to be drilled using a drilling jig that has been set up for left and right hand parts and will ensure accurate placement of all holes. <p>Other processes to consider:</p> <ul style="list-style-type: none"> • Candidates may start by cutting out layers of the individual pieces on a CNC laser cutter. If taking this approach they should demonstrate consideration of how each layer of ply will shift in 		<p>sound knowledge of some aspects of how to ensure accuracy when forming the plywood frame, with reasonable use of technical terms and consideration of any processes, equipment and machinery required. Sketches used will be for the most part clear and supported with notes most of which are relevant.</p> <p>Level 1 (1–2 marks)</p> <p>The candidate will demonstrate a limited knowledge of how to ensure accuracy when forming the plywood frame, applying this knowledge in a basic way with a limited use of technical terms and basic consideration of any processes, equipment and/or machinery required. Sketches and/or notes will be unclear.</p> <p>Level 0 (0 marks)</p> <p>No response or no response worthy of credit.</p>

Question			Answer	Marks	Guidance
			<p>alignment when there are glued over the former. Oversizing and tidying up with a CNC router or drilling holes later using a jig may be suggested.</p> <ul style="list-style-type: none"> They should also consider a jig or former with a recess to stop movement with the layers are being formed and laminated in the vacuum. <p>Award credit for any other appropriate response.</p>		
Question			Answer	Marks	Guidance
4	(d)	(i)	<p>Three justified responses from:</p> <p>Developing a larger seat pan will give greater support to the patients when using the balance bike. (✓)</p> <p>Adapting the front wheel fork to two wheels will offer more stability when turning corners to that the patient is less likely to fall over and injure themselves further. (✓)</p> <p>Developing a lock and pivot mechanism to enable the seat to be tilted/altered, making it easier for the patient to climb onto the bike. (✓)</p> <p>Award credit for any other appropriate response.</p>	<p>3</p> <p>AO3</p> <p>1b</p>	<p>1 mark for each justified response.</p> <p>If the response is not justified no mark can be awarded.</p> <p>Specific reference to suitability function for both the balance bike and patient mobility is needed for the marks.</p>

Question			Answer	Marks	Guidance	
4	(d)	(ii)	<p>Indicative content:</p> <p>The bike is likely to be used by many different patients as once they're rehabilitated they will no longer require its use, therefore it is essential that the balance bike is highly adaptable otherwise its use will be very limited and it may become obsolete very quickly.</p> <p>If being used by patients who are limited in their mobility there is more of a risk of damage when adjusting components or moving patients on and off the bike, if it isn't robust in the way it is modified it may fall into disrepair or need regular maintenance to sustain its lifecycle.</p> <p>If made robustly and with many adjustable and user friendly adaptations it may be a product that has heavy use, this could cause problems, but would also mean that it has importance in the hospital and therefore looked after well.</p> <p>Award credit for any other appropriate response.</p>	<p>6</p> <p>AO3</p> <p>AO4 4 x 2c</p>	<p>Content</p> <p>All processes demonstrated in the candidate's response must be in relation to the modifications to the balance bike and have full consideration of the needs of the stakeholders involved.</p> <hr/> <p>A candidate operating at Level 3 would be expected to access all of the AO4 (2c) marks and at least one of the AO3 (2b) marks.</p> <p>A candidate operating at Level 2 would be expected to access most of the AO4 (2c) marks, and at least one of AO3 (2b) marks.</p> <p>A candidate operating at Level 1 would only be expected to access AO4 (2c) marks.</p>	<p>Levels of response</p> <p>Level 3 (5–6 marks)</p> <p>The candidate produces a thorough discussion of the implications on the product lifecycle of the modified balance bike. Candidate shows a mature understanding and analysis of the wider issues in the question that relate to the stakeholders involved. This creates a discussion that is both cohesive and well-considered.</p> <p>Level 2 (3–4 marks)</p> <p>The candidate produces a sound discussion of the implications on the product lifecycle of the modified balance bike. Candidate shows a reasonable understanding and analysis of the wider issues in the question that relate to the stakeholders involved. This creates a discussion that is for the most part cohesive and well-considered.</p> <p>Level 1 (1–2 marks)</p> <p>The candidate demonstrates basic knowledge of the implications on the product</p>

Question			Answer	Marks	Guidance
					<p>lifecycle of the modified balance bike. Any understanding is limited with little consideration of the wider issues that relate to the stakeholders involved. There is n analysis or evaluation.</p> <p>Level 0 (0 marks) No response or no response worthy of credit.</p>

Question		Answer	Marks	Guidance
5	(a)	<p>Social sustainability influences on design thinking:</p> <p>Designers and consumers have become very conscious of the fair treatment of those that have an interest in the development of a product (✓) therefore fairtrade initiatives have had a heavy influence on designers (✓) in relation to ensuring that the materials and components they are planning to use come from sources where communities and workers are treated fairly with wages and benefits (✓)</p> <p>Award credit for any other appropriate response.</p>	<p>3</p> <p>AO4</p> <p>1 x 2a</p> <p>2 x 2b</p>	<p>1 mark for identifying an influence of social sustainability on design thinking.</p> <p>2 marks for expansion of the point</p>

Question	Answer	Marks	Guidance
<p>5 (b)</p>	<p>Marketing impact on product sustainability:</p> <p>market pull factors can increase the demand for a product (✓) this can have a negative impact on product sustainability of older products as this can often encourage users to upgrade their product sooner than they need to risking the old product becoming obsolete (✓)</p> <p>If a product has good marketing and branding and becomes highly recognised (✓) this can result in the product sustaining itself well in the market and drawing in great profits for the manufacturer and/or designer (✓)</p> <p>Other examples include:</p> <ul style="list-style-type: none"> • Focusing on a USP • Improving consumer awareness and hooking them to a product • Poor quality marketing can turn users away from quality products. <p>Award credit for any other appropriate response.</p>	<p>4</p> <p>AO4</p> <p>2 x 2a</p> <p>2 x 2b</p>	<p>1 mark for each of two identified impacts marketing has on product sustainability.</p> <p>1 mark for explanation of each impact</p> <p>Responses could take a positive or negative approach.</p>

Question			Answer	Marks	Guidance	
					Content	Levels of response
5	(c)	*	Indicative content:	8	Do not accept benefits to the consumer, the community, or to the environment. Do not accept vague references to harming the environment, environmentally friendly, eco-friendly, global warming, ozone layer, endangered species/habitats, pollution.	Level 3 (6–8 marks) The candidate produces a thorough discussion of the benefits and drawbacks to a manufacturer of designing and making products to reduce environmental impact. The candidate shows a mature understanding and analysis of the wider issues in the question and their discussion is more cohesive and well considered as a result.
			<p>Benefits to a manufacturer could include: PR/good publicity Meeting customers’ environmental standards Reducing costs Helping conserve resources. Easier disposal Less harmful waste.</p> <p>Explanation/justification could be in the form of: So that the manufacturer can show that their output reduces environmental impact Help to promote a good image for the manufacturer Result in higher sales.</p> <p>To save manufacturers money Reduced carbon footprint/CO2 Tax incentives/Grant. Higher performing candidates will link in the positive PR benefits.</p> <p>Draw backs can be expensive, need to meet targets, prove material sources, test pollution levels etc.</p> <p>Every stage in the life-cycle, from the raw material extraction through to the end of the product’s life.</p> <p>Examples could include:</p> <ul style="list-style-type: none"> mobile phone only used for twelve to eighteen months before it is replaced, so a mobile phone 			

		<p>company might want to examine the amount and mixture of materials from which it is made to help minimize any impacts associated with its dismantling and disposal, the company would need to consider its manufacturing using as little (and as few) materials as possible.</p> <ul style="list-style-type: none"> • If a company is looking to reduce its carbon footprint, or look at transport efficiency, as the distribution of the product may well cause the biggest production of carbon, material used in the product or its packaging; for example, using Aluminium that is made from 60% recycled content can reduce the product's embedded carbon by up to 90%, recyclability of the materials from which the product or packaging is made. • Minimize the different types of materials used and, if possible, move to a single material product. Look at how the materials are fixed together; for example, moving from screws to snap clips reduces the amount of time it takes to dismantle the product and they could also be made from the same material. • Most modern materials can include high levels of recycled content, for example cardboard boxes, metals and most plastics. An obvious and commonly-used example is the Innocent Drinks bottle, one of the 		<p>and analysis of the wider issues in the question and their discussion is for the most part well-structured and considered.</p> <p>There is a line of reasoning presented with some structure. The information presented is in the most-part relevant and supported by some evidence.</p> <p>Level 1 (1–2 marks) The candidate demonstrates knowledge of the benefits and drawbacks to a manufacturer of designing and making products to reduce environmental impact. Any understanding is limited with little consideration given to wider environmental issues. There is no analysis or evaluation.</p> <p>The information has some relevance and is presented with limited structure or detail. The information is supported by limited evidence.</p> <p>Level 0 (0 marks) No response or no response worthy of credit.</p>
--	--	---	--	---

		<p>first to be made from 100% recycled PET. By asking suppliers for more recycled content in the materials purchased, costs can often be cut and money can be saved. But recycling plastic costs more than making virgin materials.</p> <ul style="list-style-type: none">• Can the packaging be designed so that more products fit onto one pallet? <p>Award credit for any other appropriate response</p>			
--	--	--	--	--	--

Assessment Objectives (AO) grid

Question	AO3	AO4
1a	3	
1b		4
1c		4
1d		2
1e*	4	4
2a	2	4
2b		2
2c	2	2
3a		2
3b		5
3c		8
3d		3
4a		2
4bi		2
4bii		2
4biii	2	1
4c		6
4di	3	
4dii	2	4
5a		3
5b		4
5c*	4	4
Total	22	68
Overall Total		90

BLANK PAGE