

OCR

Oxford Cambridge and RSA

Tuesday 17 May 2016 – Afternoon**AS GCE ELECTRONICS****F611/01** Simple Systems

Candidates answer on the Question Paper.

OCR supplied materials:

None

Other materials required:

- Scientific calculator

Duration: 1 hour 30 minutes

Candidate forename		Candidate surname	
-----------------------	--	----------------------	--

Centre number						Candidate number				
---------------	--	--	--	--	--	------------------	--	--	--	--

INSTRUCTIONS TO CANDIDATES

- Write your name, centre number and candidate number in the boxes above. Please write clearly and in capital letters.
- Use black ink. HB pencil may be used for graphs and diagrams only.
- Answer **all** the questions.
- Read each question carefully. Make sure you know what you have to do before starting your answer.
- Write your answer to each question in the space provided. Additional paper may be used if necessary but you must clearly show your candidate number, centre number and question number(s).
- Do **not** write in the bar codes.

INFORMATION FOR CANDIDATES

- The number of marks is given in brackets [] at the end of each question or part question.
- The total number of marks for this paper is **90**.
- Quality of Written Communication will be assessed in this paper.
- You are advised to show all the steps in any calculations.
- This document consists of **16** pages. Any blank pages are indicated.



**A calculator may
be used for this
paper**

Data Sheet

Unless otherwise indicated, you can assume that:

- op-amps are run off supply rails at +15V and -15V.
- logic circuits are run off supply rails at +5V and 0V.

resistance	$R = \frac{V}{I}$
power	$P = VI$
series resistors	$R = R_1 + R_2$
time constant	$\tau = RC$
monostable pulse time	$T = 0.7 RC$
relaxation oscillator period	$T = 0.5 RC$
frequency	$f = \frac{1}{T}$
Boolean Algebra	$A \cdot \bar{A} = 0$ $A + \bar{A} = 1$ $A \cdot (B + C) = A \cdot B + A \cdot C$ $\overline{A \cdot B} = \bar{A} + \bar{B}$ $\overline{A + B} = \bar{A} \cdot \bar{B}$ $A + A \cdot B = A$ $A \cdot B + \bar{A} \cdot C = A \cdot B + \bar{A} \cdot C + B \cdot C$

Answer **all** questions.

- 1 Fig. 1.1 shows a circuit for controlling a white LED for use as a bedroom reading lamp.

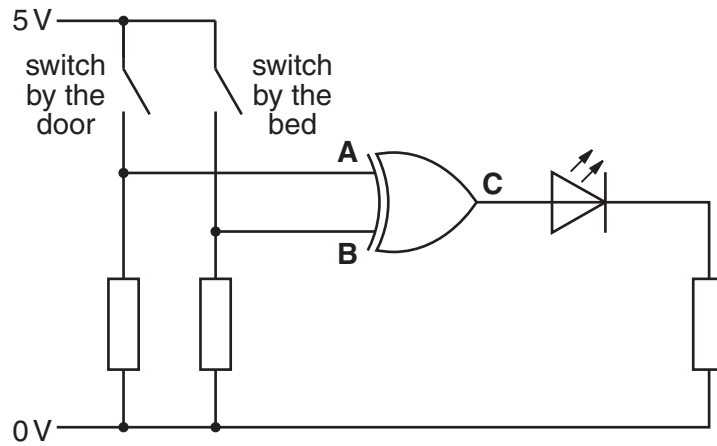

Fig. 1.1

- (a) Name the logic gate in Fig. 1.1.

..... [1]

- (b) Complete the truth table below for the logic gate in Fig. 1.1.

A	B	C

[2]

- (c) One possible expression for **C** is $C = A \oplus B$
Write an alternative Boolean expression for **C** in terms of **A** and **B**.

C = [1]

- (d) Use the truth table to explain how the LED can be turned on or off with the switch by the bed taking account of the state of the switch by the door.

.....

 [2]

2 Fig. 2.1 shows a circuit containing an LED.

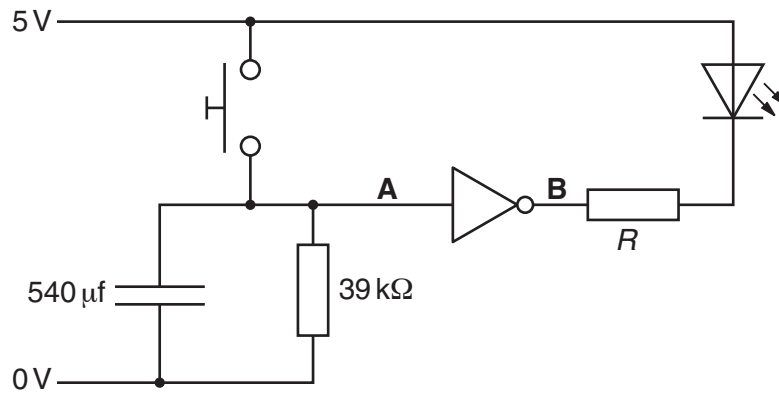

Fig. 2.1

(a) The LED in Fig. 2.1 has a forward voltage of 2.2V at a current of 15 mA. Calculate the value of R to limit the current through the LED to 15 mA.

$R = \dots\dots\dots \Omega$ [2]

(b) Draw a graph of the current-voltage characteristics of the LED on the axes in Fig. 2.2.

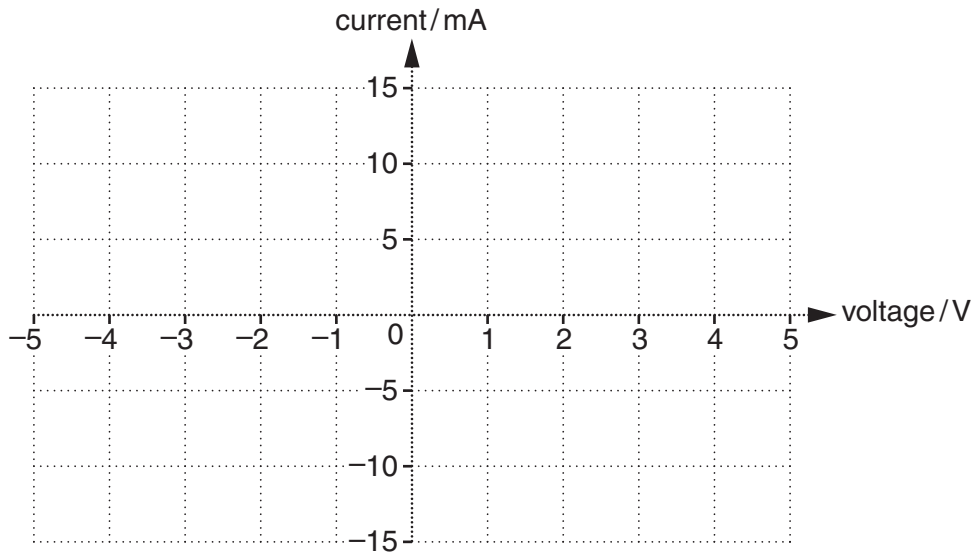

Fig. 2.2

[3]

(c) Explain what happens to the LED when the switch in Fig. 2.1 is pressed and held down.

.....

.....

.....

.....

..... [4]

(d) Show that the circuit produces a delay of about 15 s when the switch is released.

[2]

(e) Complete the graphs to show how the voltages at **A** and **B** change with time.

NOT gate input	NOT gate output
< 2.5V	5V
≥ 2.5V	0V

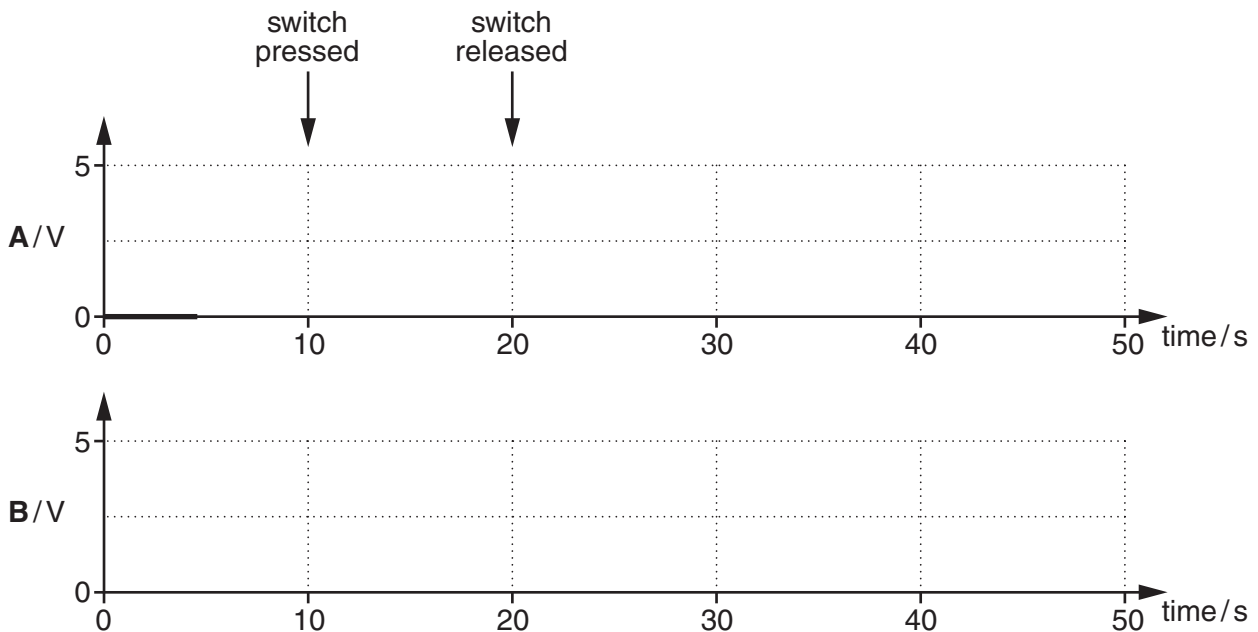

[5]

3 Fig. 3.1 shows a circuit that makes a warning sound.

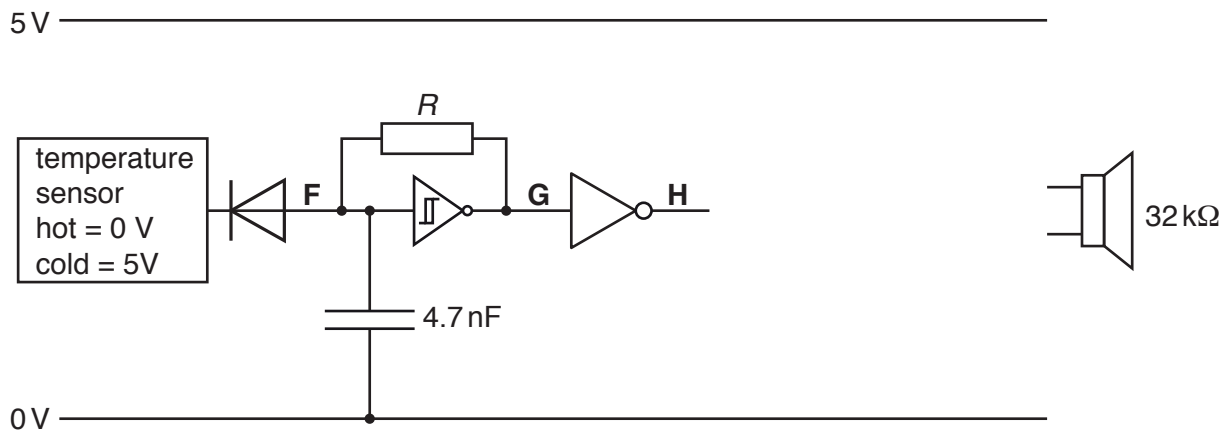

Fig. 3.1

(a) Draw on Fig. 3.1 to show how a MOSFET should be connected to produce a loud sound from the speaker.

Label the terminals of the MOSFET with their correct names. [5]

(b) Explain why the MOSFET is needed.

.....

.....

..... [2]

(c) Calculate the value of R to give the relaxation oscillator a frequency of 3 kHz.

$R = \dots\dots\dots \Omega$ [3]

(d) The temperature sensor contains a thermistor. Draw the circuit symbol for a thermistor.

[1]

- (e) Explain how the circuit behaves when it is cold and when it is hot. Refer to the voltages at points **F**, **G** and **H** in your answer.

.....

.....

.....

.....

.....

.....

..... [5]

8

4 This question is about using the rules of Boolean algebra.

(a) Put a **ring** around the Boolean expression which matches to the truth table.

E	F	R
0	0	1
0	1	1
1	0	0
1	1	1

$$R = \bar{E} + F \quad R = (E \cdot \bar{F}) \quad R = (\bar{E} \cdot F) \quad R = E \cdot (\bar{E} \cdot \bar{F})$$

[1]

(b) Put a **ring** around the Boolean expression which matches to the truth table.

A	B	Q
0	0	0
0	1	1
1	0	0
1	1	0

$$Q = (A + B) \cdot (\bar{A} + \bar{B}) \quad Q = B \cdot (\bar{A} + \bar{B}) \quad Q = \overline{\bar{A} + B} \quad Q = (\overline{A + B}) \cdot (\overline{A + B})$$

[1]

(c) Put a **ring** around the Boolean expression which matches to the truth table.

C	D	P
0	0	1
0	1	1
1	0	0
1	1	0

$$P = \bar{C} + D \quad P = (\bar{C} \cdot D) \cdot D \quad P = (\bar{D} + D) \cdot \bar{C} \quad P = (\bar{C} + \bar{D}) \cdot (C + D)$$

[1]

9

(d) Put a ring around the Boolean expression which matches to the truth table.

A	B	Q
0	0	0
0	1	1
1	0	0
1	1	0

$$Q = \bar{A} + B$$

$$Q = \bar{A} \cdot \bar{B} + A \cdot \bar{B} + A \cdot B$$

$$Q = \overline{\bar{A} \cdot \bar{B}} + A$$

$$Q = \overline{A \cdot B}$$

[1]

10

- 5 The diagram in Fig. 5.1 shows a circuit for controlling a lamp.

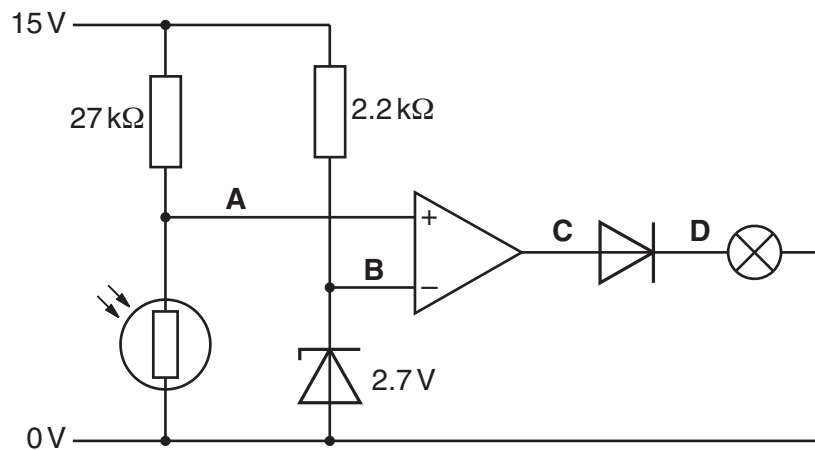

Fig. 5.1

- (a) Explain how the zener diode and $2.2\text{ k}\Omega$ resistor keep the inverting terminal of the op-amp at 2.7 V .

.....

 [3]

- (b) Calculate the current flowing through the zener diode.

current = A [2]

- (c) The circuit contains an LDR. Describe the electrical properties of an LDR.

.....
 [2]

- (d) Show that the voltage at the non-inverting input of the op-amp is about 3 V when the resistance of the LDR is $7\text{ k}\Omega$.

[3]

- (e) Explain why the lamp glows when the resistance of the LDR is $7\text{ k}\Omega$.

.....

.....

.....

..... [3]

- (f) Calculate the maximum resistance of the LDR that will make the lamp turn off.

maximum resistance of the LDR = $\text{k}\Omega$ [2]

- (g) Explain why the diode is included in the circuit.

.....

.....

..... [4]

- (h) The lamp has a power of 2 W when it is turned on. Calculate the current in the lamp when it is turned on.

current = A [2]

- (i) Select the most appropriate diode for the circuit from the table.

Diode part number	Reverse voltage max (V)	Forward current max (mA)	Price each
BAT43	30	200	14p
1N914	100	75	25p
BAT46	100	150	13p
BAV21	250	250	28p

diode part number [1]

6 Here is the truth table for a logic system.

J	K	M	Q
0	0	0	0
0	0	1	1
0	1	0	0
0	1	1	1
1	0	0	0
1	0	1	1
1	1	0	0
1	1	1	0

(a) Write a Boolean expression for Q in the truth table. You do not need to simplify the expression.

Q = [1]

(b) Draw a logic circuit with the behaviour of this truth table on Fig. 6.1. You may use any logic gates you need in your design.

J _

K _

– Q

M _

Fig. 6.1

[2]

(c) Draw on Fig. 6.1 the necessary components and connections to show how a switch can make K high when it is pressed and low when it is released. [2]

13

7 The block diagram for an alarm is shown in Fig. 7.1.

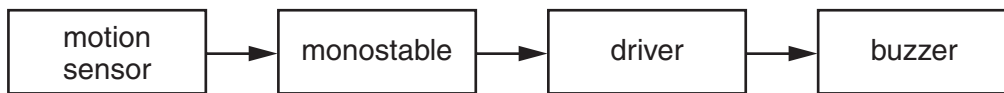

Fig. 7.1

(a) Give **one** reason for using block diagrams as well as circuit diagrams when designing circuits.

.....
 [1]

(b) The monostable needs to have a period of 15 seconds.
 Draw the circuit diagram of the monostable below using NAND gates.
 Show all of your calculations and component values.

[4]

8 Fig. 8.1 shows a logic system.

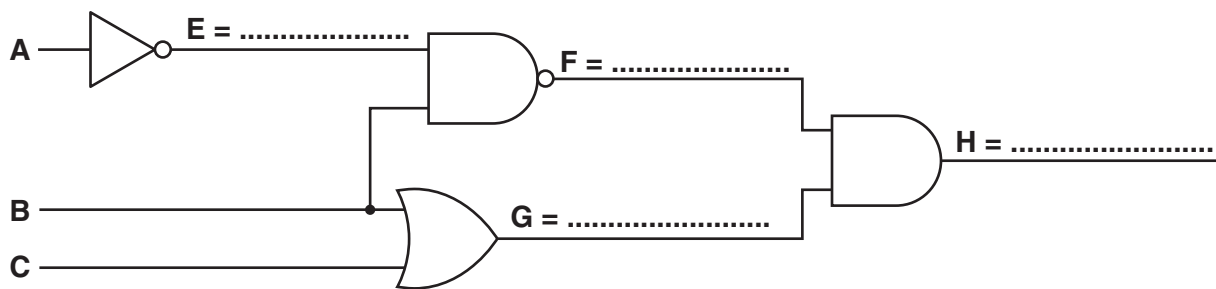

Fig. 8.1

- (a) On Fig. 8.1 write the Boolean expression for the output of each gate using **only** the letters **A**, **B** and **C**. You do not need to simplify your expressions. [4]
- (b) Complete the truth table below for the logic circuit in Fig. 8.1.

A	B	C	E	F	G	H
0	0	0				
0	0	1				
0	1	0				
0	1	1				
1	0	0				
1	0	1				
1	1	0				
1	1	1				

[4]

(c) Show how the circuit in Fig. 8.1 can be constructed using only NAND gates. Label the points **A**, **B**, **C**, **E**, **F**, **G** and **H** in your diagram.

[4]

(d) State an advantage of building a logic circuit using only NAND gates.

.....
..... [1]

Quality of written communication [3]

END OF QUESTION PAPER

PLEASE DO NOT WRITE ON THIS PAGE



Copyright Information

OCR is committed to seeking permission to reproduce all third-party content that it uses in its assessment materials. OCR has attempted to identify and contact all copyright holders whose work is used in this paper. To avoid the issue of disclosure of answer-related information to candidates, all copyright acknowledgements are reproduced in the OCR Copyright Acknowledgements Booklet. This is produced for each series of examinations and is freely available to download from our public website (www.ocr.org.uk) after the live examination series.

If OCR has unwittingly failed to correctly acknowledge or clear any third-party content in this assessment material, OCR will be happy to correct its mistake at the earliest possible opportunity.

For queries or further information please contact the Copyright Team, First Floor, 9 Hills Road, Cambridge CB2 1GE.

OCR is part of the Cambridge Assessment Group; Cambridge Assessment is the brand name of University of Cambridge Local Examinations Syndicate (UCLES), which is itself a department of the University of Cambridge.