

OCR

Oxford Cambridge and RSA

Friday 17 June 2016 – Morning**A2 GCE ELECTRONICS****F615/01** Communication Systems

Candidates answer on the Question Paper.

OCR supplied materials:

None

Other materials required:

- Scientific calculator

Duration: 1 hour 40 minutes

Candidate forename		Candidate surname	
-----------------------	--	----------------------	--

Centre number						Candidate number				
---------------	--	--	--	--	--	------------------	--	--	--	--

INSTRUCTIONS TO CANDIDATES

- Write your name, centre number and candidate number in the boxes above. Please write clearly and in capital letters.
- Use black ink. HB pencil may be used for graphs and diagrams only.
- Answer **all** the questions.
- Read each question carefully. Make sure you know what you have to do before starting your answer.
- Write your answer to each question in the space provided. Additional paper may be used if necessary but you must clearly show your candidate number, centre number and question number(s).
- Do **not** write in the bar codes.

INFORMATION FOR CANDIDATES

- The number of marks is given in brackets [] at the end of each question or part question.
- The total number of marks for this paper is **110**.
- Quality of written communication will be assessed in this paper.
- You are advised to show all the steps in any calculations.
- This document consists of **20** pages. Any blank pages are indicated.

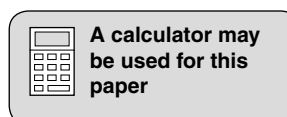

Data Sheet

Unless otherwise indicated, you can assume that:

- op-amps are run off supply rails at +15V and –15V
- logic circuits are run off supply rails at +5V and 0V.

resistance	$R = \frac{V}{I}$
power	$P = VI$
series resistors	$R = R_1 + R_2$
time constant	$\tau = RC$
monostable pulse time	$T = 0.7 RC$
relaxation oscillator period	$T = 0.5 RC$
frequency	$f = \frac{1}{T}$
voltage gain	$G = \frac{V_{\text{out}}}{V_{\text{in}}}$
open-loop op-amp	$V_{\text{out}} = A(V_+ - V_-)$
non-inverting amplifier gain	$G = 1 + \frac{R_f}{R_d}$
inverting amplifier gain	$G = -\frac{R_f}{R_{\text{in}}}$
summing amplifier	$-\frac{V_{\text{out}}}{R_f} = \frac{V_1}{R_1} + \frac{V_2}{R_2} \dots$
break frequency	$f_0 = \frac{1}{2\pi RC}$

3

Boolean Algebra

$$A.\bar{A} = 0$$

$$A + \bar{A} = 1$$

$$A.(B + C) = A.B + A.C$$

$$\overline{A.B} = \bar{A} + \bar{B}$$

$$\overline{A + B} = \bar{A}.\bar{B}$$

$$A + A.B = A$$

$$A.B + \bar{A}.C = A.B + \bar{A}.C + B.C$$

amplifier gain

$$G = -g_m R_d$$

ramp generator

$$\Delta V_{\text{out}} = -V_{\text{in}} \frac{\Delta t}{RC}$$

inductor reactance

$$X_L = 2\pi fL$$

capacitor reactance

$$X_C = \frac{1}{2\pi fC}$$

resonant frequency

$$f_0 = \frac{1}{2\pi\sqrt{LC}}$$

Answer **all** the questions.

1 The incomplete circuit of Fig. 1.1 provides a test signal for a small single-colour display.

The screen displays a series of vertical black or white bars.

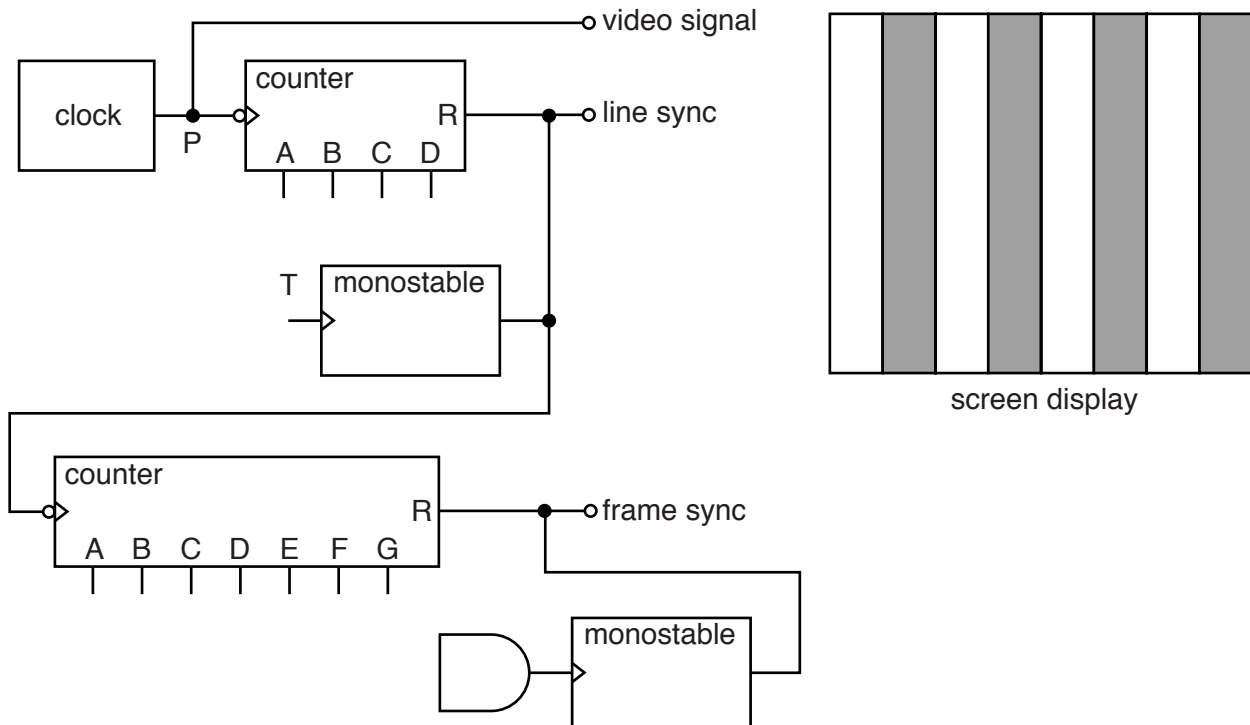

Fig. 1.1

(a) The line sync signal is generated by a monostable whose input T is connected to one of the outputs of the four-bit counter.

Draw on Fig. 1.1 to show the connection from the four-bit counter to T.

Use the screen display to justify your answer.

.....

.....

.....

..... [3]

(b) The video display has 128 columns of pixels arranged in 100 rows.

Draw on Fig. 1.1 to show how the seven-bit counter should be connected to the AND gate. Justify your answer.

.....
.....
.....
.....
..... [3]

(c) The bandwidth of the video signal is 384 kHz.

(i) Calculate the frame refresh rate of the display and comment on its value.

refresh rate = s⁻¹

.....
.....
..... [4]

(ii) Explain the effect on the display of using a cable which has a bandwidth of 50 kHz for the 384 kHz video signal.

.....
.....
.....
..... [2]

6

(d) Each rising edge at T makes the line sync signal pulse high for $28\mu\text{s}$.

Draw a suitable NAND gate circuit for the monostable in the space below.

Include all component values and justify them with calculations.

[4]

[Total: 16]

2 Fig. 2.1 is the oscilloscope trace of an amplitude modulated (AM) carrier.

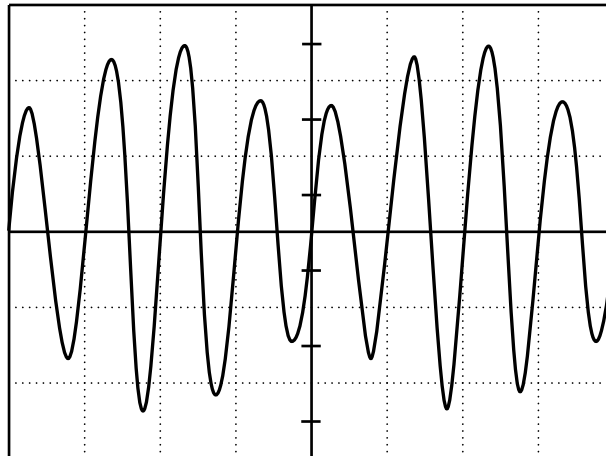

Fig. 2.1

(a) The settings of the oscilloscope are as follows:

- timebase setting $20\ \mu\text{s}/\text{div}$
- vertical scale $500\ \text{mV}/\text{div}$.

(i) Calculate the amplitude and frequency of the **modulating signal**.

amplitude = mV

frequency = kHz
[3]

(ii) Complete the amplitude-frequency graph of the AM carrier shown in Fig. 2.1.

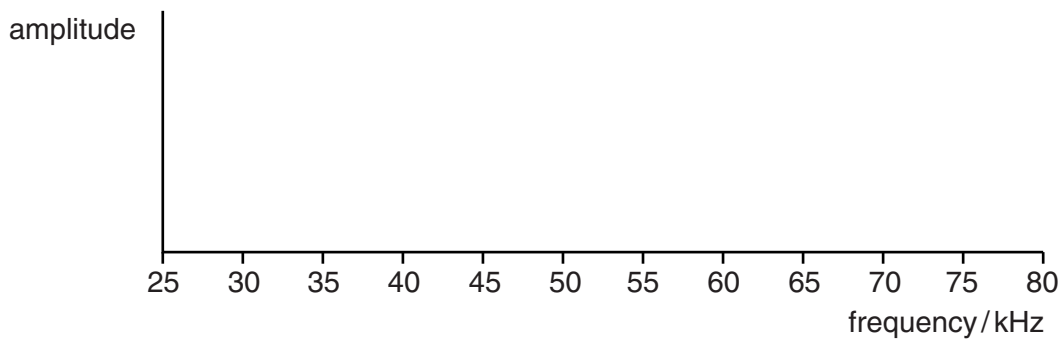

Fig. 2.2

[3]

(b) In the space below, draw a suitable demodulator for the amplitude modulated carrier shown in Fig. 2.1. Show all component values and justify them with calculations.

[3]

[Total: 9]

3 This question is about the use of wireless microphones.



In the UK, wireless microphones can be used without a licence in the broadcast frequency range 173.8MHz to 175.0MHz. Each microphone uses frequency modulation (FM), with a bandwidth of 200kHz.

(a) (i) Suggest the maximum number of microphones which can operate simultaneously at a single venue without a licence.

Justify your answer with calculations.

maximum number = [2]

(ii) A greater range of frequencies is available for wireless microphones in the frequency range 854MHz to 862MHz, but their use requires a licence from the government. Suggest why a licence is required.

.....

.....

.....

..... [2]

(b) The number of microphones can be increased by using amplitude modulation (AM) instead of FM.

(i) Describe the difference between AM and FM.

.....
.....
.....
.....
..... [3]

(ii) Calculate the maximum number of microphones which can be used without a licence at a venue with AM.

maximum number = [2]

(iii) Explain the advantage of using FM instead of AM for a wireless microphone.

.....
.....
.....
.....
.....
.....
.....
.....
..... [4]

[Total: 13]

10

4 The circuit of Fig. 4.1 is a modulator for pulse-width modulation (PWM) systems.

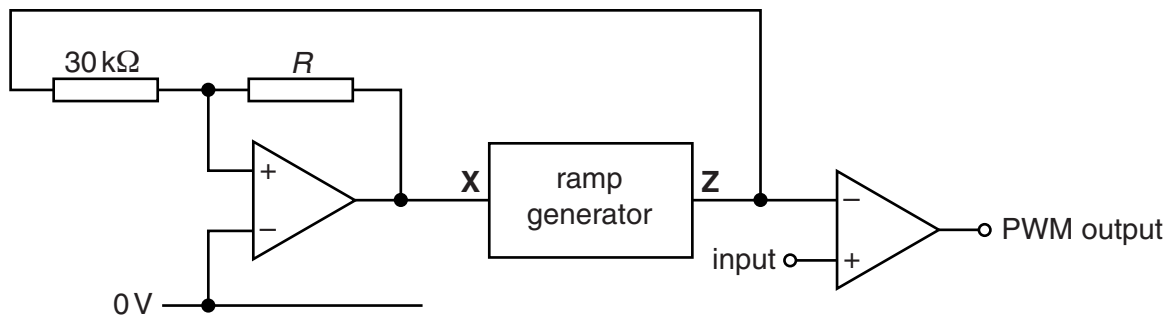

Fig. 4.1

(a) The signal at **Z** is a triangle wave with the following properties:

- amplitude 7.5V
- frequency 20 kHz.

(i) Draw a voltage-time graph for the signal at **Z** on the axes of Fig. 4.2. Label it **Z**.

[3]

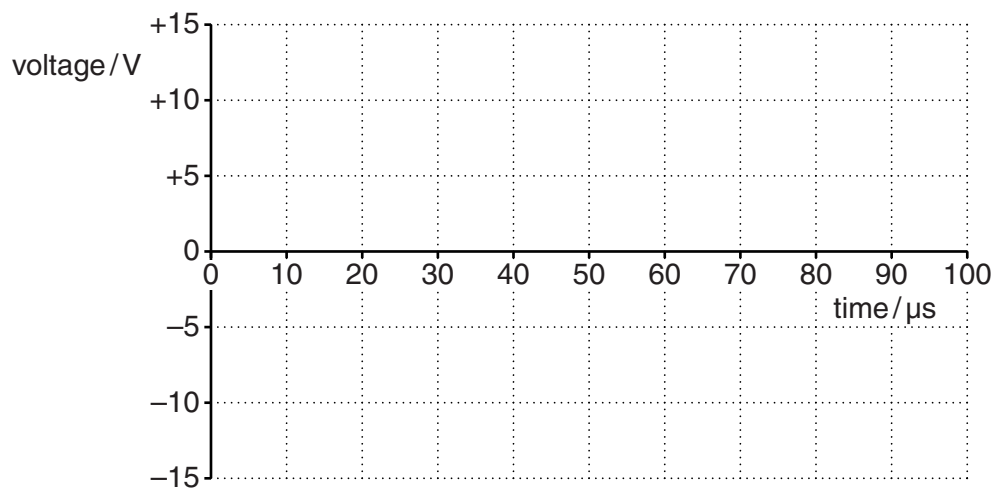

Fig. 4.2

(ii) Draw a voltage-time graph for the signal at **X** on the axes of Fig. 4.2. Label it **X**.

[3]

(iii) Calculate a suitable value R for the resistor.

$R = \dots\dots\dots$ k Ω [2]

(b) Explain why the system of Fig. 4.1 only operates correctly for signals whose amplitude and frequency are less than 7.5V and 10kHz respectively.

.....

.....

.....

.....

..... [2]

(c) Complete the circuit of Fig. 4.3 to show how a filter with a gain of 2.5 can be used as a PWM demodulator for signals in the range 0 to 2 kHz.

Show all component values and justify them with calculations.

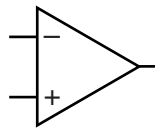

Fig. 4.3

[5]

[Total: 15]

5 On their way from the transmitter to the receiver, radio waves pick up interference. This reduces the quality of the information extracted by the receiver.

(a) What is interference?

.....
.....
..... [2]

(b) Explain the effect of increasing the distance between transmitter and receiver on the quality of information extracted by the receiver.

.....
.....
.....
.....
.....
.....
..... [4]

(c) Suggest **two** other ways that modulated carriers can be sent over large distances which are less affected by interference than radio waves.

.....
.....
..... [2]

[Total: 8]

6 Fig. 6.1 is an incomplete block diagram for a simple AM radio receiver.

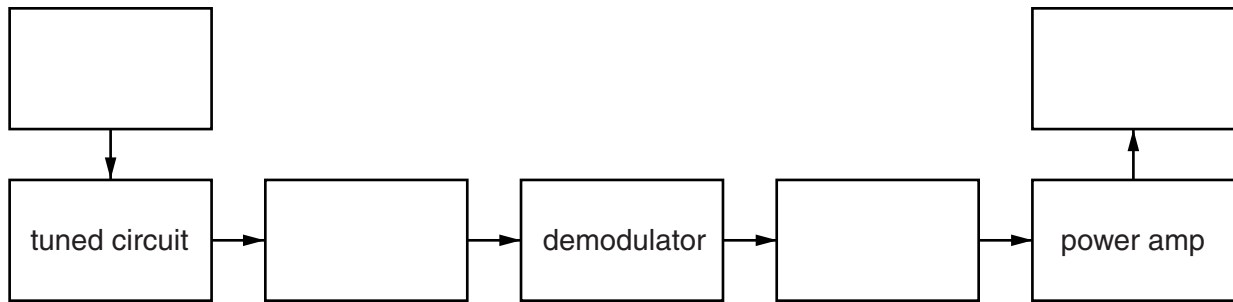

Fig. 6.1

(a) Complete the block diagram of Fig. 6.1. [4]

(b) (i) Complete the tuned circuit of Fig. 6.2, labelling the input and output.
 Give component values appropriate for a carrier frequency of 470 kHz.
 Justify them with calculations.

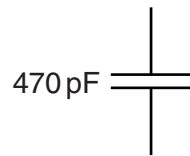

Fig. 6.2

[4]

(ii) Explain how the tuned circuit performs its function in the radio receiver.

.....

.....

.....

.....

.....

.....

.....

.....

.....

..... [5]

[Total: 13]

7 Fig. 7.1 shows an incomplete circuit for a 2-bit analogue-to-digital converter (ADC).

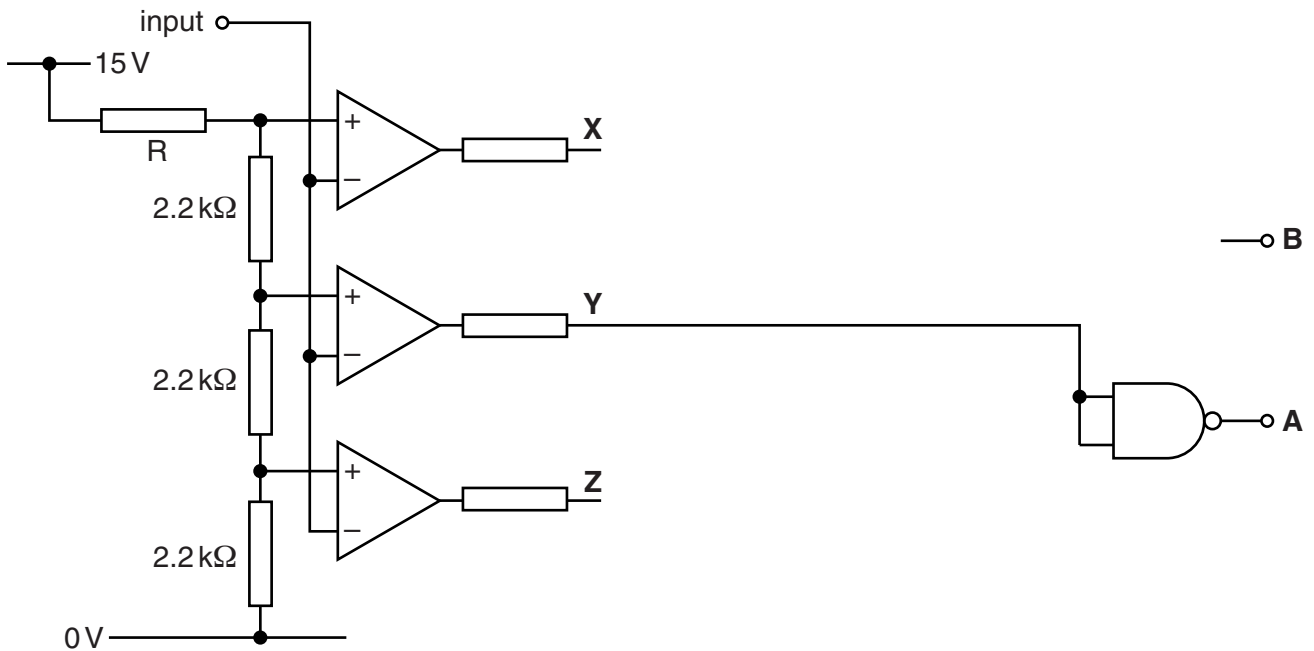

Fig. 7.1

(a) The converter is required to have a resolution of 0.5V.

Calculate a suitable value for the resistor **R** of Fig. 7.1.

R = kΩ [3]

(b) The missing part of the circuit of Fig. 7.1 is required to obey this incomplete truth table.

Input range / V	X	Y	Z	B	A
1.50 to 1.99				1	1
1.00 to 1.49				0	1
0.50 to 0.99				1	0
0.00 to 0.49				0	0

(i) Complete the table with the words **high** and **low**. [2]

(ii) Write down a Boolean expression for **B** in terms of **X**, **Y** and **Z**.

..... [1]

(iii) On Fig. 7.1, draw a NAND gate circuit to generate **B**. [3]

(c) Fig. 7.2 is an incomplete digital-to-analogue converter.

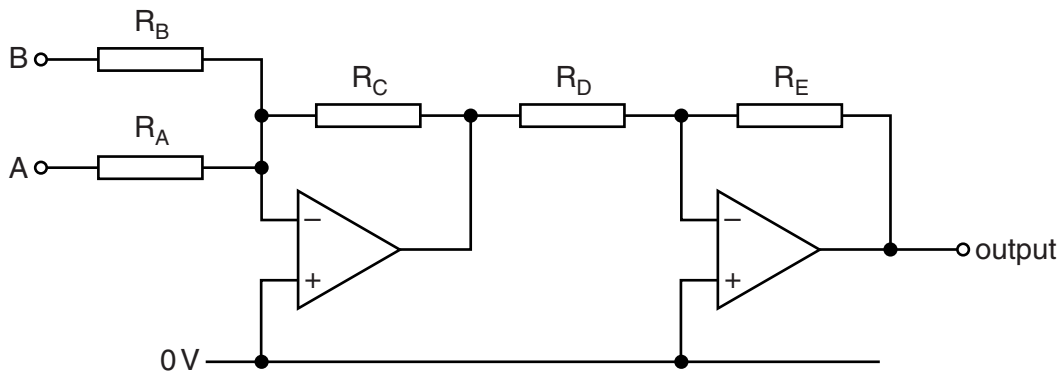

Fig. 7.2

Select component values for it to have a resolution of 0.5V.

Justify your values with calculations.

$R_A = \dots\dots\dots \text{ k}\Omega$

$R_B = \dots\dots\dots \text{ k}\Omega$

$R_C = \dots\dots\dots \text{ k}\Omega$

$R_D = \dots\dots\dots \text{ k}\Omega$

$R_E = \dots\dots\dots \text{ k}\Omega$

[3]

[Total: 12]

16

- 8 Fig. 8.1 is an incomplete block diagram of a digital transmission system which sends four different analogue signals from one place to another across a link.

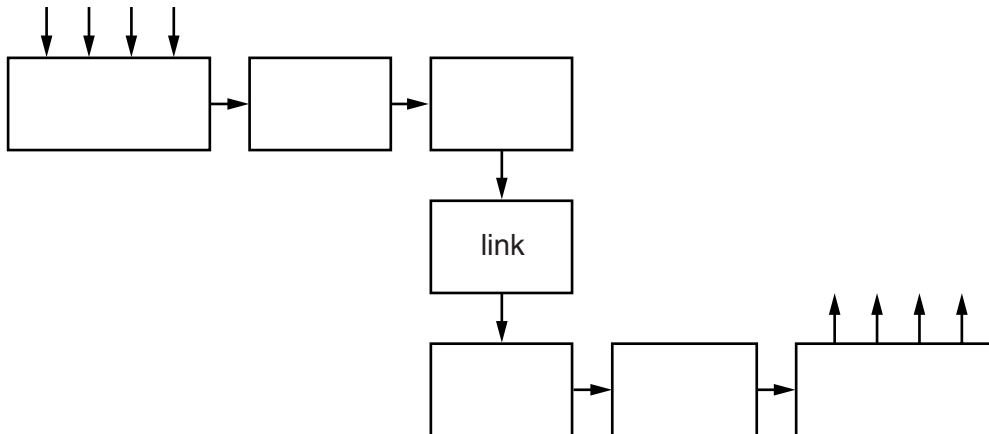

Fig. 8.1

- (a) Complete the block diagram. Use symbols from this table of names.

Name of block	Symbol
multiplexer	MUX
demultiplexer	DMUX
Schmitt trigger	ST
bandpass filter	BF
serial-to-parallel converter	SPC
parallel-to-serial converter	PSC
analogue-to-digital converter	ADC
digital-to-analogue converter	DAC

[6]

(b) The link carries 12-bit words, each of which starts with 0 and ends with 1.

(i) Explain the function of the bits at the start and the end of each word.

.....
.....
.....
..... [3]

(ii) Each of the four analogue signals being transmitted has a frequency in the range 150 Hz to 15 kHz.

Calculate the minimum bandwidth required to send all of the information across the link.

bandwidth = kHz [3]

(iii) Each of the four analogue signals being transmitted has a maximum amplitude of 1.2 V.

Calculate the resolution of the analogue-to-digital converter.

resolution = mV [3]

[Total: 15]

9 Fig. 9.1 shows a four-input multiplexer for analogue signals placed at the inputs S_0 to S_3 .

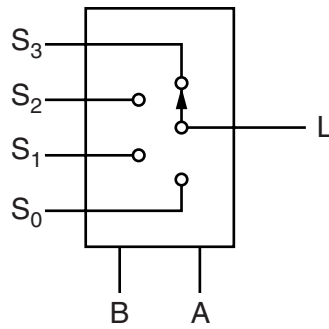

Fig. 9.1

(a) The multiplexer is part of a system which uses time division multiplexing (TDM) to send four different analogue signals down a single link.

Describe the transfer characteristic of the multiplexer.

.....
.....
.....
..... [3]

(b) Explain what is meant by the term TDM.

.....
.....
.....
..... [3]

[Total: 6]

Quality of written communication [3]

END OF QUESTION PAPER

PLEASE DO NOT WRITE ON THIS PAGE

PLEASE DO NOT WRITE ON THIS PAGE



Copyright Information

OCR is committed to seeking permission to reproduce all third-party content that it uses in its assessment materials. OCR has attempted to identify and contact all copyright holders whose work is used in this paper. To avoid the issue of disclosure of answer-related information to candidates, all copyright acknowledgements are reproduced in the OCR Copyright Acknowledgements Booklet. This is produced for each series of examinations and is freely available to download from our public website (www.ocr.org.uk) after the live examination series. If OCR has unwittingly failed to correctly acknowledge or clear any third-party content in this assessment material, OCR will be happy to correct its mistake at the earliest possible opportunity.

For queries or further information please contact the Copyright Team, First Floor, 9 Hills Road, Cambridge CB2 1GE.

OCR is part of the Cambridge Assessment Group; Cambridge Assessment is the brand name of University of Cambridge Local Examinations Syndicate (UCLES), which is itself a department of the University of Cambridge.