

OCR

Oxford Cambridge and RSA

Tuesday 19 May 2015 – Morning**LEVEL 1/2 CAMBRIDGE NATIONAL AWARD/CERTIFICATE IN
PRINCIPLES IN ENGINEERING AND ENGINEERING BUSINESS****R101/01** Engineering principles

Candidates answer on the Question Paper.

OCR supplied materials:

None

Other materials required:

- A calculator may be used

Duration: 1 hour

Candidate forename		Candidate surname	
-----------------------	--	----------------------	--

Centre number						Candidate number				
---------------	--	--	--	--	--	------------------	--	--	--	--

INSTRUCTIONS TO CANDIDATES

- Use black ink. HB pencil may be used for graphs and diagrams only.
- Complete the boxes above with your name, centre number and candidate number.
- Answer **all** the questions.
- Write your answer to each question in the space provided.
- Do **not** write in the bar codes.

INFORMATION FOR CANDIDATES

- The total number of marks for this paper is **60**.
- The number of marks for each question is given in brackets [] at the end of the question or part question.
- Dimensions are in millimetres unless stated otherwise.
- Your quality of written communication will be assessed in questions marked with an asterisk (*).
- This document consists of **12** pages. Any blank pages are indicated.

Answer **all** the questions.

1 (a) Fig. 1 shows a mechanical system to lift a load using two pulleys.

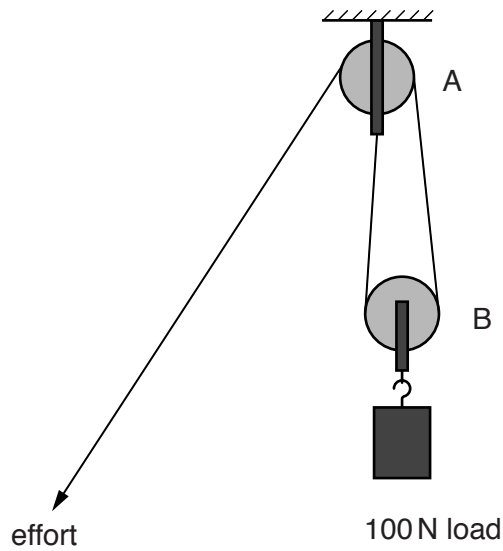

Fig. 1

(i) Describe the effect of using the pulley system in Fig. 1.

.....
.....
.....
..... [2]

(ii) Explain what is meant by the term 'mechanical efficiency'.

.....
.....
.....
..... [2]

(iii) State the basic unit of power.

..... [1]

3

- (b) (i) All moving objects have kinetic energy.
Calculate the kinetic energy of a 1000 kilogram load travelling at 5 metres per second.

Use the formula $W_{KE} = \frac{1}{2}mv^2$

.....

 [3]

- (ii) Complete the table below. The first row has been done for you.

Form of energy	Definition	Example
Mechanical	Energy associated with motion and position of an object	Flywheel
Potential		
Heat		

[4]

- (iii) An alternator driven by an engine is used to charge the battery on a fork lift truck. Complete the statements below to describe the energy conversions that take place in order for the headlights and horn to work.

Mechanical energy from the engine is used to drive the alternator, charging the battery providing current. The energy produced by the battery creates energy in the form of current which powers the horn, producing energy and powers the headlights, producing energy.

[4]

2 (a) Fig. 2 shows a gear assembly.

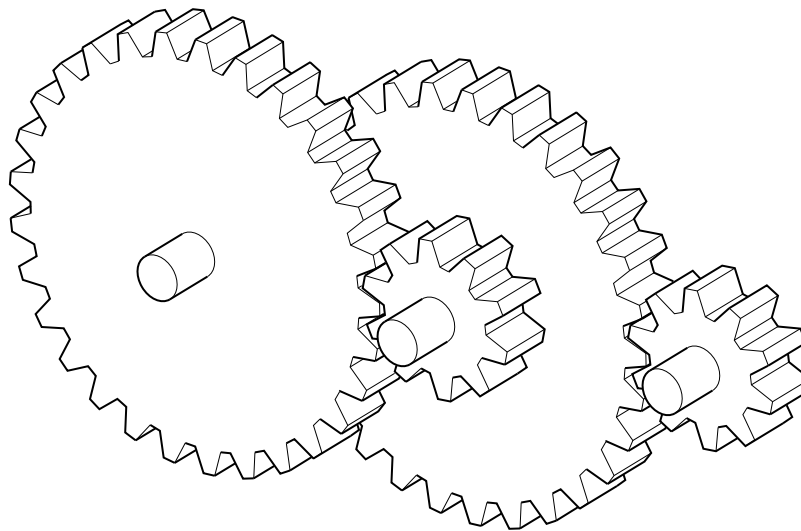

Fig. 2

(i) State the type of gear assembly shown in Fig. 2.

..... [1]

(ii) Describe **one** advantage this type of gear arrangement has over a simple spur gear train.

.....
.....
.....
..... [2]

(iii) Give **one** application of the gear arrangement shown in Fig. 2.

..... [1]

(b) Fig. 3 shows a pulley system.

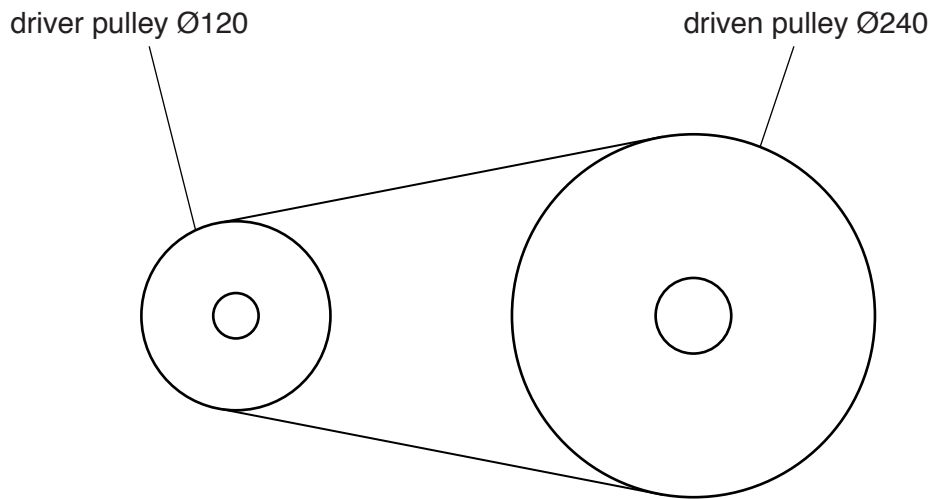

Fig. 3

(i) State the formula used for velocity ratio.

..... [1]

(ii) Calculate the velocity ratio of the pulley arrangement shown in Fig. 3.

.....
.....
..... [2]

(iii) State the speed of rotation of the driven pulley when the driver pulley is turning at 200 revolutions per minute.

..... [1]

3 (a) Describe how a generator produces an electric current.

.....
.....
.....
.....
.....
..... [3]

(b) Explain what is meant by the term 'potential difference'.

.....
.....
.....
..... [2]

(c) Show what is meant by the term 'Alternating Current' using a sketch graph.



[3]

4 (a) Fig. 4 shows a circuit using three ammeters.

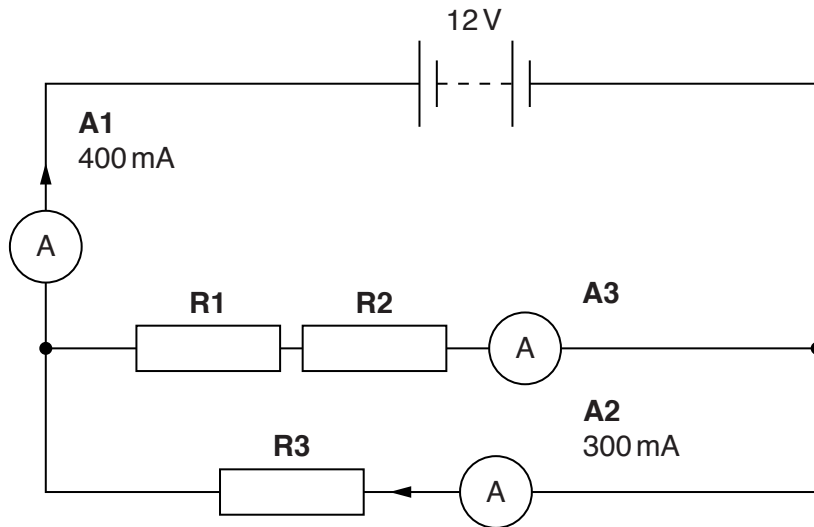

Fig. 4

(i) State the reading that would be shown on ammeter **A3**.

..... [1]

(ii) Draw a voltmeter on the circuit in Fig. 4 to measure the potential difference across **R2**. [2]

(iii) Calculate the current that would be shown on ammeter **A2** if the resistor **R3** is replaced with a 2W lamp.

Use the formula $P = VI$

.....

 [2]

5 Fig. 5 shows a simplified circuit for a manually operated pneumatic parking barrier.

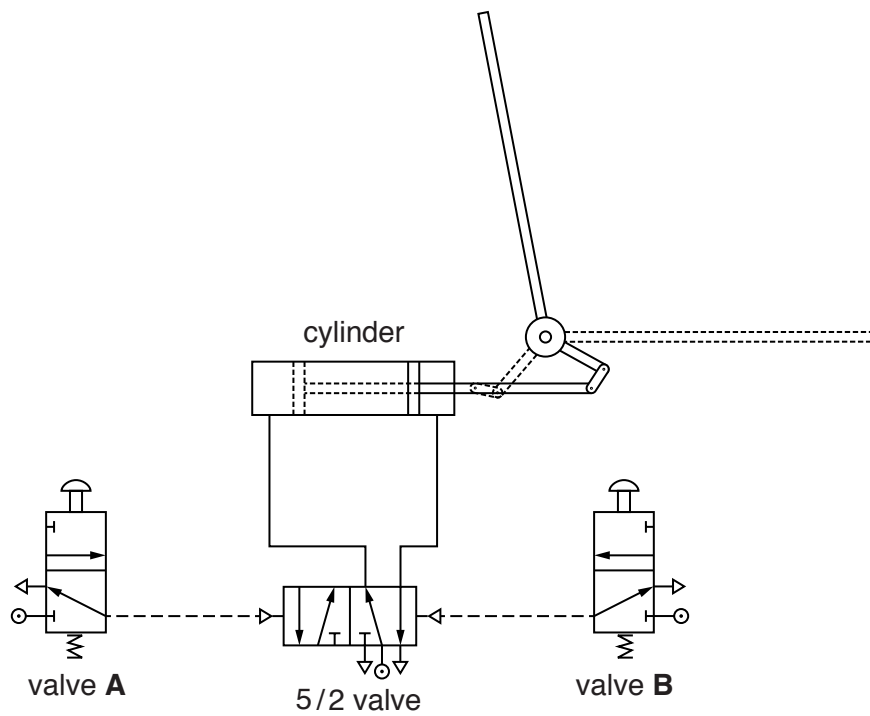

Fig. 5

(a) Describe what would be required to produce, store and deliver the compressed air needed to operate the barrier.

.....

.....

.....

.....

.....

.....

.....

..... [3]

(b) (i) State what type of actuator is used in Fig. 5.

..... [1]

(ii) State how valves A and B are operated.

..... [1]

(iii) Describe the operation of the parking barrier circuit shown in Fig. 5.

.....

.....

.....

.....

.....

.....

.....

.....

.....

..... [5]

6 (a) Describe the differences in the use of the air in pneumatic systems and the fluid in hydraulic systems.

.....
.....
.....
.....
.....
..... [3]

(b) A hydraulic ram is used to move a bucket on a mechanical digger.

Describe how fluid is used to control the operation of the ram.

.....
.....
.....
.....
.....
.....
.....
..... [4]

(c)* Discuss the advantages of using pneumatics rather than hydraulics in the manufacture of food products.

.....
.....
.....
.....
.....
.....
.....
.....
.....
.....
.....
.....
.....
.....
.....
.....
.....
.....
.....
.....
.....
.....
.....
.....
.....
.....
.....
.....
.....
.....
.....
.....
.....
.....
.....
.....
.....
.....
.....
.....
.....
.....
.....
.....
.....
.....

[6]

END OF QUESTION PAPER

PLEASE DO NOT WRITE ON THIS PAGE



Copyright Information

OCR is committed to seeking permission to reproduce all third-party content that it uses in its assessment materials. OCR has attempted to identify and contact all copyright holders whose work is used in this paper. To avoid the issue of disclosure of answer-related information to candidates, all copyright acknowledgements are reproduced in the OCR Copyright Acknowledgements Booklet. This is produced for each series of examinations and is freely available to download from our public website (www.ocr.org.uk) after the live examination series.

If OCR has unwittingly failed to correctly acknowledge or clear any third-party content in this assessment material, OCR will be happy to correct its mistake at the earliest possible opportunity.

For queries or further information please contact the Copyright Team, First Floor, 9 Hills Road, Cambridge CB2 1GE.

OCR is part of the Cambridge Assessment Group; Cambridge Assessment is the brand name of University of Cambridge Local Examinations Syndicate (UCLES), which is itself a department of the University of Cambridge.