

A LEVEL

Examiners' report

DESIGN AND TECHNOLOGY: PRODUCT DESIGN

H406

For first teaching in 2017

H406/01 Summer 2019 series

Version 1

Contents

Introduction	3
Paper 1 series overview	4
Question 1 (a)	5
Question 1 (b)	6
Question 1 (c)	7
Question 1 (d)	8
Question 1 (e)	8
Question 1 (f)	11
Question 2 (a)	12
Question 2 (b)	13
Question 2 (c) (i)	13
Question 2 (c) (ii)	14
Question 2 (d)	14
Question 2 (e)	15
Question 3 (a)	16
Question 3 (b)	17
Question 4 (a) (i)	18
Question 4 (a) (ii)	20
Question 4 (a) (iii)	20
Question 4 (a) (iv)	22
Question 4 (b)	23
Question 4 (c)	23
Copyright information	24



Would you prefer a Word version?

Did you know that you can save this pdf as a Word file using Acrobat Professional?

Simply click on **File > Save As Other ...** and select **Microsoft Word**

(If you have opened this PDF in your browser you will need to save it first. Simply right click anywhere on the page and select **Save as ...** to save the PDF. Then open the PDF in Acrobat Professional.)

If you do not have access to Acrobat Professional there are a number of **free** applications available that will also convert PDF to Word (search for *pdf to word converter*).



We value your feedback

We'd like to know your view on the resources we produce. By clicking on the icon above you will help us to ensure that our resources work for you.

Introduction

Our examiners' reports are produced to offer constructive feedback on candidates' performance in the examinations. They provide useful guidance for future candidates. The reports will include a general commentary on candidates' performance, identify technical aspects examined in the questions and highlight good performance and where performance could be improved. The reports will also explain aspects which caused difficulty and why the difficulties arose, whether through a lack of knowledge, poor examination technique, or any other identifiable and explainable reason.

Where overall performance on a question/question part was considered good, with no particular areas to highlight, these questions have not been included in the report. A full copy of the question paper can be downloaded from OCR.

Paper 1 series overview

This component is the first of two examined components and makes up 26.7% of the total A Level qualification.

This paper is set out through four sets of questions that predominantly cover technical principles within Product Design.

Questions require candidates to:

- analyse existing products
- demonstrate applied mathematical skills
- demonstrate their technical knowledge of materials, product functionality, manufacturing processes and techniques
- demonstrate their understanding of wider social, moral and environmental issues that impact on the design and manufacturing industries.

To do well in this component candidates need to analyse modern consumer products that are designed to meet consumer needs, their design and manufacture, and show understanding of product development and industrial and commercial practices. candidates are tested on a range of materials and components used in the manufacture of commonly available products, as outlined in the specification.

Candidates need to show clear understanding of topics through extended written responses and support discussions with evaluation and use of examples. In Mathematical skills questions candidates need to show workings, if an incorrect answer is given but the method is correct, candidates can gain access to some marks.

Many of the questions within the paper are based on a particular consumer product, candidates are expected to analyse the product and refer to it in context to support their answers.

Question 1 (a)

1 Fig. 1 shows three images of a selfie stick. A selfie stick is a hand held product used to take photographs or video by holding a smartphone, beyond the normal range of the arm.

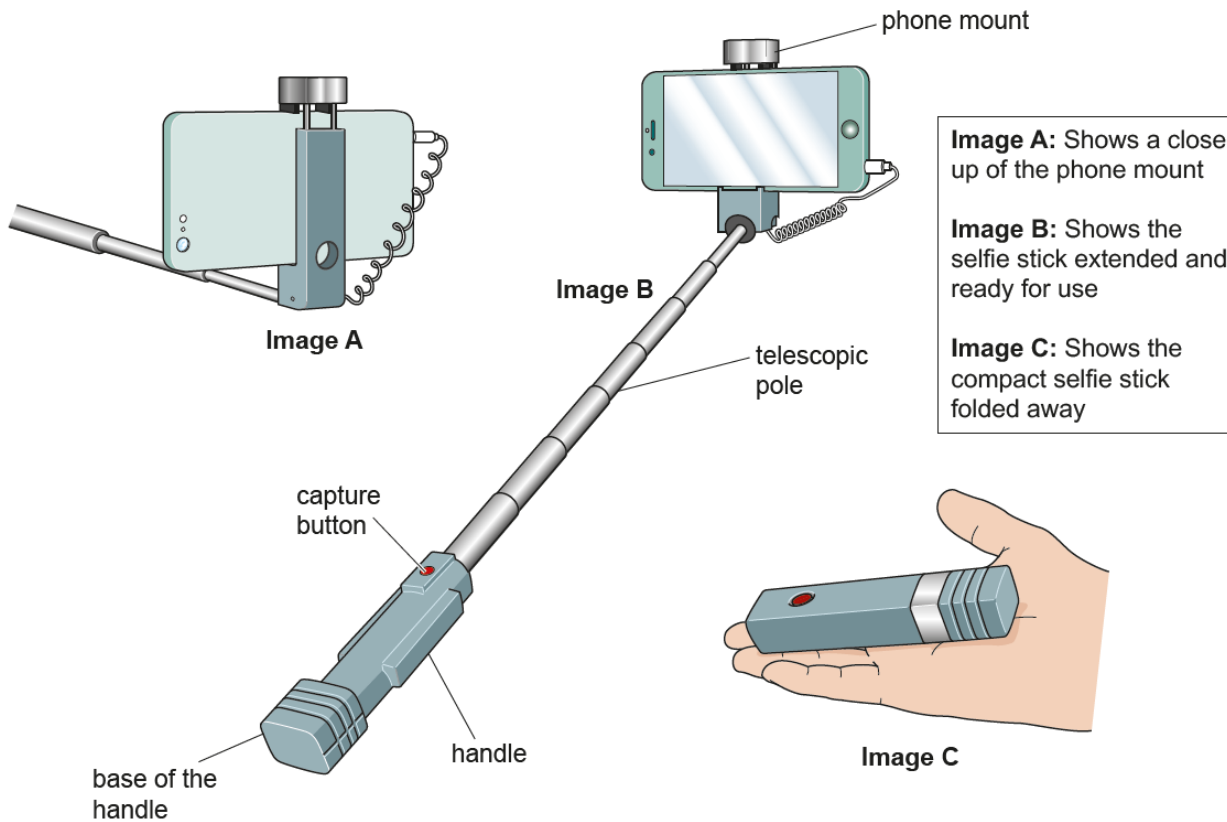

Fig. 1

(a) Analyse Fig. 1 to identify **two** design features of the selfie stick that ensure it functions as intended. Justify **each** of your responses.

1

.....

.....

.....

.....

.....

.....

.....

.....

.....

[4]

This question required candidates to analyse a selfie stick and identify two design features that help its functionality.

Most candidates identified two features and justified their responses fully accessing all available marks.

Responses just giving parts that were labelled without further explanation of how this part aids the product to function gained no marks.

Exemplar 1

- 1 The pole extends (telescopic) allowing the user to adjust the distance of the phone from their face - this is required as otherwise the user won't be able to take photos from a range greater than their hand.
- 2 The selfie stick closes into a compact shape that is easy to hold and transport - this feature is needed to ensure the product is portable and easily accessible / stored by the user.

Exemplar 1 identifies two features, the ability to extend beyond the arm, and be able to adjust the distance and the ability to close and be compact, both points are justified in relation to use so the response gained the full marks available.

Question 1 (b)

- (b) Name **one** metal that is suitable for the telescopic pole of the selfie stick and explain why this would be used.

.....

.....

.....

..... [2]

The majority of candidates named a suitable metal. The most commonly named were aluminium or stainless steel.

Some candidates went on to describe the properties of the material but to gain the full marks reference to the selfie stick was needed.

Question 1 (c)

- (c) The maximum length of the selfie stick is 585mm from the base of the handle to the phone mount. The handle is 116mm long and the rest of the extension comes from the telescopic pole.

The telescopic pole is made up of 7 sections.

Each section is cut to the same length.

3mm of each section is covered by the larger section next to it including the section attached to the handle.

Calculate the length of one section of the telescopic pole in mm. Show your working.

Length of one section mm

[2]

This was a mathematical question testing simple calculations and many candidates gained full marks.

A number of candidates didn't add the 3mm, gaining only one of the available marks.

Candidates who show no working and present a wrong final answer are awarded zero, it is advisable that all candidates are encouraged to show their workings. Exemplar 2 clearly shows workings.

Exemplar 2

length of pole = $585 - 116 = 469 \text{ mm}$

~~469~~ $469 / 7 = 67 \text{ mm}$

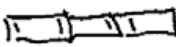
\therefore  = 67

$\therefore 67 + 3 = 70$

Length of one section ⁷⁰..... mm

Question 1 (d)

(d) Explain **three** advantages to the designer of the selfie stick of using modelling during the iterative design process.

1

.....

.....

.....

.....

2

.....

.....

.....

.....

3

.....

.....

.....

[6]

This question was answered well with most candidates gaining at least three marks. The advantages of modelling as part of the iterative design process needed to be explained to access the full marks available.

Question 1 (e)

(e) Design optimisation is an important part of the iterative design process.

Discuss how the design and manufacture of the selfie stick could be optimised to keep costs as low as possible.

.....

.....

.....

.....

.....

.....

.....

.....

[6]

There were some good responses to this question, referring to use of standardised parts, reduction in material quantity, size, wall thickness, reducing the number of materials to reduce manufacturing stages. Some responses also referred to the use of software such as FEA (finite element analysis) or using structural methods such as algorithms to remove materials without compromising strength etc.

There was some misunderstanding of optimisation, so some candidates just talked about making the design easier to manufacture, rather than optimising it to make the best choices from design alternatives.

	AfL	<p>Design optimisation is a new term for A Level specifications, it is expected in the NEA that candidates present “modification and consideration of clearly defined design optimisation presented” of their idea, design optimisation should be taught to support this.</p> <p>Although candidates may not have access to FEA CAD software, learning about how this is used can help them understand the concept of optimisation. Autodesk have several free videos to help explain the concept one of which is https://www.autodesk.com/solutions/generative-design</p>
---	------------	---

Exemplar 3

The manufacture of the selfie stick could be optimised through the use of CAD or Computer aided engineering. This is because the software allows you to simulate the forces that would be applied to the selfie stick. As a result the designers could use this software to check how scaling back on ~~material~~ the amount of materials used affects the durability and strength of the product ~~with~~ thus allowing them to come up with a design that uses the least required material without actually producing a prototype.

The selfie stick could also be optimised to ~~use~~ include less parts in its structure. As a result the manufacturing process would likely require less specialised equipment and would once again use less material.

The selfie stick could also be designed to use materials of less quality for its construction. This would mean ^[6] the costs of buying the materials would drop.

The selfie stick could be optimised to include standardised components. This would drop down on manufacturing costs as it means that those components don't have to be produced by the manufacturer themselves.

Exemplar 3 gained full marks, mentioning use of CAD to test the structure with forces and adapt the design, as well as reference to less material, less parts and the use of standardised components.

Question 1 (f)

- (f) Past and present technologies and design thinking have influenced the development of products in many different ways.

Describe **three** ways that past and present technologies and design thinking have influenced products such as the selfie stick.

1

.....

.....

.....

.....

2

.....

.....

.....

.....

3

.....

.....

.....

[6]

This question required candidates to consider how past and present technologies and design thinking have influenced the development of products. Some candidates referred only to the selfie stick while others drew on examples of other products.

Responses covered new technologies such as Bluetooth, AI, GPS and VR influencing product development.

Design thinking was covered by aspects like the influence of systems thinking, usability and sustainability.. Some candidates referred to past design movements and designers such as Dieter Rams and Bauhaus and the influence of form following function.

Question 2 (a)

2 Fig. 2.1 shows two views of a remote control for an electronic device.



Fig. 2.1

- (a) The top surface of the battery hatch, shown in Fig. 2.1, is a rectangle measuring 30 mm wide and 60 mm long correct to the nearest mm. Calculate the upper bound of the area of this rectangle in mm^2 . Show your working.

Upper bound mm^2

[2]

This was a mathematical question where candidates calculated the upper bound of an area.

A significant number of candidates were unable to recognise the upper bounds and this question therefore tended to be simply right or wrong.

Question 2 (b)

- (b) The remote control batteries have a life span of approximately 75 hours. The remote control is used, on average, approximately 3 minutes every day. Estimate the number of years before the user will have to replace the batteries. Show your working.

Approximately years

[2]

This was a well answered maths question with most gaining full marks. Candidates again should be encouraged to show workings out.

Question 2 (c) (i)

- (c) During quality control testing the red power and yellow photo buttons sometimes failed.

The probability that the red power button fails is $\frac{1}{120}$

The probability that the yellow photo button fails is $\frac{1}{750}$

- (i) Complete the probability tree diagram below.

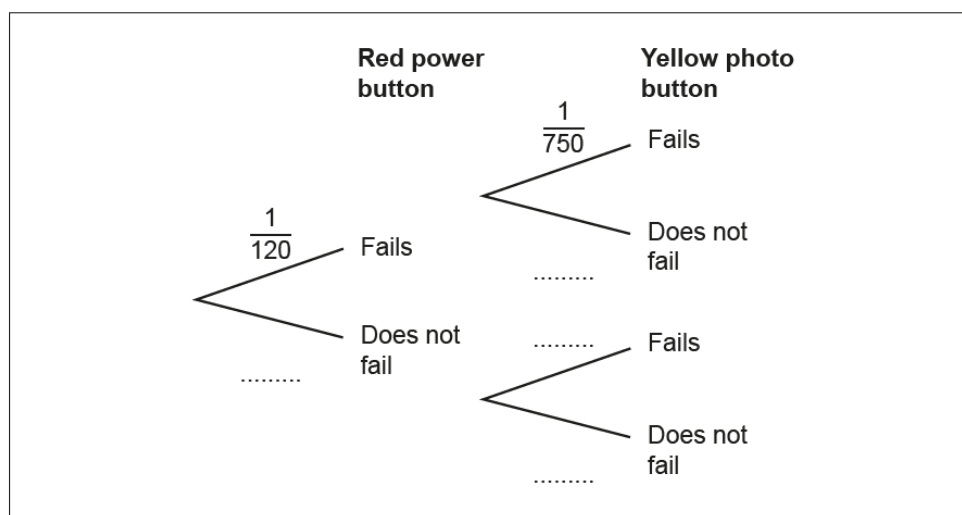

[2]

This question was a well answered maths question with most gaining full marks.

Candidates were required to complete a probability tree diagram and generally understood how to do this.

Question 2 (c) (ii)

(ii) Calculate the probability that both buttons fail. Show your working.

Probability

[2]

This question required candidates to calculate the probability and was not so well answered with a significant number of candidates adding the two together instead of multiplying. Probability is M7 within the specification. This question required candidates to derive and apply the formula $p(A \text{ and } B) = p(A \text{ given } B)p(B)$.

Question 2 (d)

(d) Describe **two** ways in which ergonomic factors would be considered when designing the buttons on the remote control.

1

.....

.....

.....

.....

2

.....

.....

.....

[4]

This question was well answered.

Some candidates referred to ergonomics of the remote without any reference to the buttons. Credit was given for these responses but reference to the layout, shape, colour and size of the buttons or use of a non-slip material were needed to access the full range of marks.

Question 2 (e)

Fig. 2.2 shows a CAD diagram of the central buttons in the lower part of the remote control. Arc X is part of the outer circumference of a circular array of four identical buttons.

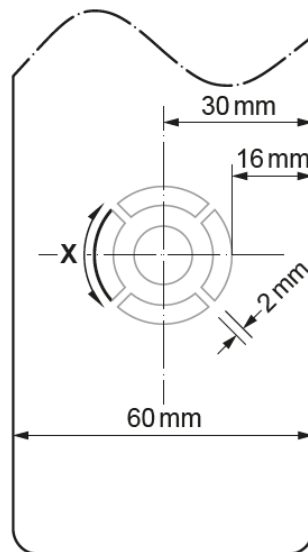

Fig. 2.2
(not to scale)

- (e) Using the diagram in Fig. 2.2, calculate the length of arc X in mm to 2 decimal places. Show your working.

The formula used to calculate the arc length of a circle is

$$\frac{\theta}{360^\circ} \times 2\pi r$$

Length of arc X mm

[4]

This was a maths question requiring a number of steps to work out the length of an arc.

A significant number of candidates scored full marks, but most gained some marks for knowing how to find the radius and angle of 90 degrees.

As this is a 4 mark question, candidates who didn't carefully show their workings would have lost access to marks.

Question 3 (a)

- 3 The understanding and use of lifecycle assessment (LCA) is important in the design and manufacture of products.

(a) Describe what is meant by the term LCA.

.....

.....

.....

.....

.....

.....

..... [4]

The majority of candidates were able to explain the term and explain it as a tool to assess the environmental impacts to include energy over all stages of a products life from the extraction of raw materials, through manufacture, transportation, use and disposal.

Some candidates were able to draw on knowledge of cradle to cradle design.

A significant number of candidates mixed up Life Cycle Analysis and a products lifecycle, writing about a products life from a marketing perspective covering launch, demand, saturation and decline.

Exemplar 6

Looking at the life of the product from
 cradle to grave and its environmental effect
 This is from the extraction of raw material and
 how this is processed to how the product is man-
 ufactured and transported and used by the
 consumer. Then how it is disassembled and
 disposed of and where the parts will end up
 after use. Carbon footprint can be calculated. [4]

Exemplar 6 presented accesses all marks available and shows a good understanding of LCA across the various stages.

Question 4 (a) (i)

- 4 **Fig. 4.1** shows a hover board. A hover board is a personal transporter which is self-balancing and allows the user to travel short distances by tilting their body in the direction of travel.

Fig. 4.2 shows the outer shell of the hover board.

Fig. 4.3 shows the four component parts of the outer shell of the hover board.



Fig. 4.1

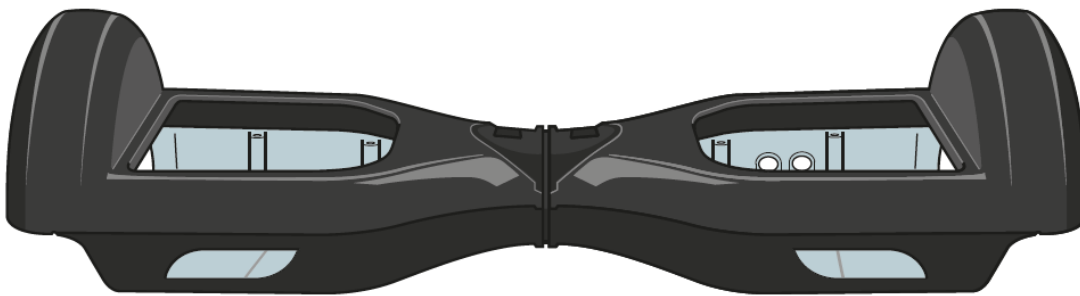

Fig. 4.2

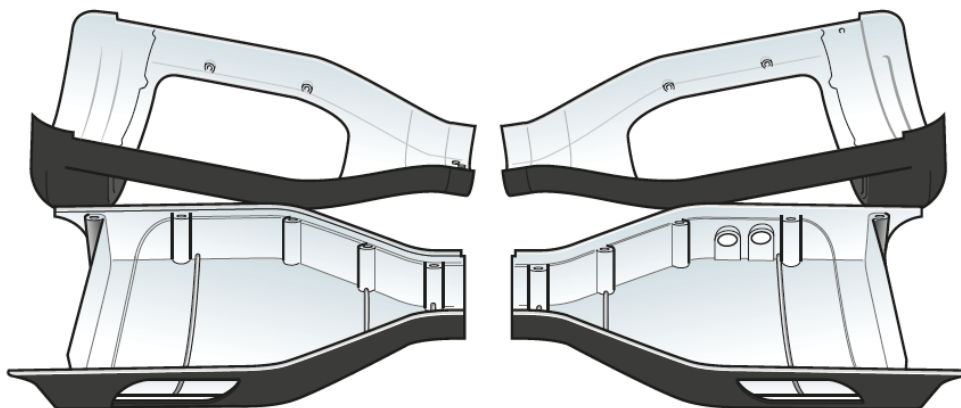

Fig. 4.3

- (a) The outer shell of the hover board shown in Fig. 4.2 is manufactured as a batch of 10 000.
- (i) Name **one** suitable thermopolymer for use in the manufacture of the component parts of the outer shell of the hover board shown in Fig. 4.3 and explain why it would be used.

.....

.....

.....

..... [2]

Most candidates were able to suggest a suitable polymer the most common answers being ABS or PP (polypropylene)

The majority were then able to identify a reason for its use usually linked to a property or characteristic of the polymer.

Exemplar 7 presented relates the properties of ABS to the hover board's use.

Exemplar 7

.....

..... ABS is tough and durable so would not ^{break} ~~break~~ if it hits something. It ~~is also~~ also comes in many colours so is aesthetically pleasing.

..... [2]

Question 4 (a) (ii)

- (ii) Identify a suitable manufacturing process for the component parts of the outer shell of the hover board shown in **Fig. 4.3**.

..... [1]

Most candidates were able to identify injection moulding as the process based on the complexity of moulding and required batch number of 10,000.

Question 4 (a) (iii)

- (iii) Use annotated sketches and/or notes to show how the process you have identified in **part (a)(ii)** would be used to manufacture the component parts of the outer shell of the hover board as a batch of 10 000.

Identify any relevant specialist tooling and quality control checks.

[8]

The majority of students were able to describe the injection moulding process.

To access the full marks in a Level 3 response, reference to the specific mouldings needed to make the hover board outer shell and quality control checks were needed.

Marks were awarded in Level 1 for reference to moulding and heating of polymer in the case of the wrong process being identified in 4c(ii).

A response can be seen below – there is some consideration of the mould and QC and the candidate is able to access the Level 3 marks.

Candidates should be encouraged to extend responses beyond a text book response and relate to the specific product.

Exemplar 8

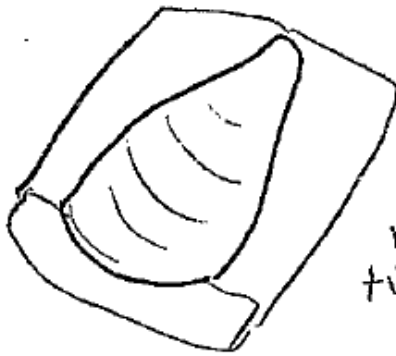

two moulds are made for the two different shell parts.

Moulds can be reused many times so is appropriate for that large batch number.

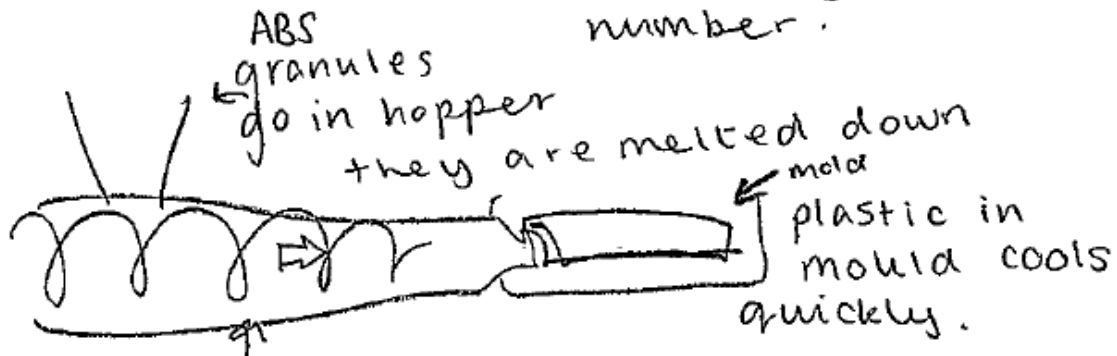

Archimedes screw pushes molten plastic in to the mould

Ejector pins pushes the parts out of the mould on a conveyor where the manufacturing continues.

Sprue is removed from the parts which may leave a sprue mark

Sprue can be snapped off or cut off when ejected.

Webbing in the mould adds strength to the part

Thread for screws is part of the mould.

Visual checks can be made after moulding.

1 in every 1000 destructively tested to check strength of part is correct standard.

Check mold every 1000 batches to ensure it has not been damaged with use.



AFL

When teaching processes or joining methods, relate these to specific products and how that products particular shape, form and detail, but also how the quantity of production lends itself to a process. This approach will also help the selection of the correct process/processes.

Question 4 (a) (iv)

- (iv) Describe **two** ways that the principles of designing for manufacture (DFM) have been incorporated in the design of the outer shell of the hover board.

1

.....

.....

.....

2

.....

.....

.....

[4]

This question required candidates to draw on knowledge of DFM (design for manufacture) and apply it to the shape of the hover board shell, identifying reasons such as integral fixings to join the two parts together minimising assembly or the shell parts being symmetrical.

Comments needed to relate to manufacture and assembly and reduction in the number of processes and parts. The answer below achieved all available marks as reasons were well described.

Exemplar 10

- 1 ... Threads and encasing for screws are combined in the shell so the number of parts needed is reduced. This reduces manufacturing steps required.
- 2 ... Symmetrical part for both sides so only 2 moulds needed for the 4 outer shell parts.

Candidates providing examples but not considering the implications were unable to access the top mark bands. Some detailed responses were seen from higher ability candidates, Exemplar 12 below considers the implications of designers and manufacturers meeting standards and supports this with examples of standards and legislations and how they are applied to products.

Exemplar 12

Designers must buy patents and intellectual property rights to ensure the legislative success of their products. Designers have a responsibility to respect other designs but applying for a patent is expensive and time-consuming. For example, Trunki produce a child's suitcase that resembles a ladybird however another company completely replicated this design at a lower cost decreasing Trunki's profit, as their patent did not cover all of the necessary legal requirements. Designers and manufacturers also have to meet standards set by the 'British Standards Institute' and other international institutions to ensure satisfaction amongst customers. However these for example products can receive a British standards "Kitemark" if they meet certain requirements, however this requires rigorous destructive testing that elongates the time it takes to get a product to market. This may be disadvantageous as a company could miss the ideal selling window. In addition, such as TVs and phones, additionally all electrical products and products eg eg toys for children must showcase the CE mark "conformite européenne" to show that it's safe for use. The standards requirements alongside legislative requirements puts pressure on designers and manufacturers to perform external tests and apply for legal help, which and both of these things are time-consuming and expensive. [8]

Copyright information

Q2 Fig 2.1 - Suradech Papairat Shutterstock.com

Supporting you

For further details of this qualification please visit the subject webpage.

Review of results

If any of your students' results are not as expected, you may wish to consider one of our review of results services. For full information about the options available visit the [OCR website](#). If university places are at stake you may wish to consider priority service 2 reviews of marking which have an earlier deadline to ensure your reviews are processed in time for university applications.

activeresults

Review students' exam performance with our free online results analysis tool. Available for GCSE, A Level and Cambridge Nationals.

It allows you to:

- review and run analysis reports on exam performance
- analyse results at question and/or topic level*
- compare your centre with OCR national averages
- identify trends across the centre
- facilitate effective planning and delivery of courses
- identify areas of the curriculum where students excel or struggle
- help pinpoint strengths and weaknesses of students and teaching departments.

*To find out which reports are available for a specific subject, please visit ocr.org.uk/administration/support-and-tools/active-results/

Find out more at ocr.org.uk/activeresults

CPD Training

Attend one of our popular CPD courses to hear exam feedback directly from a senior assessor or drop in to an online Q&A session.

Please find details for all our courses on the relevant subject page on our website.

www.ocr.org.uk

OCR Resources: *the small print*

OCR's resources are provided to support the delivery of OCR qualifications, but in no way constitute an endorsed teaching method that is required by OCR. Whilst every effort is made to ensure the accuracy of the content, OCR cannot be held responsible for any errors or omissions within these resources. We update our resources on a regular basis, so please check the OCR website to ensure you have the most up to date version.

This resource may be freely copied and distributed, as long as the OCR logo and this small print remain intact and OCR is acknowledged as the originator of this work.

Our documents are updated over time. Whilst every effort is made to check all documents, there may be contradictions between published support and the specification, therefore please use the information on the latest specification at all times. Where changes are made to specifications these will be indicated within the document, there will be a new version number indicated, and a summary of the changes. If you do notice a discrepancy between the specification and a resource please contact us at: resources.feedback@ocr.org.uk.

Whether you already offer OCR qualifications, are new to OCR, or are considering switching from your current provider/awarding organisation, you can request more information by completing the Expression of Interest form which can be found here: www.ocr.org.uk/expression-of-interest

Please get in touch if you want to discuss the accessibility of resources we offer to support delivery of our qualifications: resources.feedback@ocr.org.uk

Looking for a resource?

There is now a quick and easy search tool to help find **free** resources for your qualification:

www.ocr.org.uk/i-want-to/find-resources/

www.ocr.org.uk

OCR Customer Support Centre

General qualifications

Telephone 01223 553998

Facsimile 01223 552627

Email general.qualifications@ocr.org.uk

OCR is part of Cambridge Assessment, a department of the University of Cambridge. *For staff training purposes and as part of our quality assurance programme your call may be recorded or monitored.*

© **OCR 2019** Oxford Cambridge and RSA Examinations is a Company Limited by Guarantee. Registered in England. Registered office The Triangle Building, Shaftesbury Road, Cambridge, CB2 8EA. Registered company number 3484466. OCR is an exempt charity.



Cambridge
Assessment

