

Write your name here

Surname

Other names

**Pearson Edexcel
International GCSE**

Centre Number

--	--	--	--	--	--

Candidate Number

--	--	--	--	--

Mathematics A

Paper 2FR

**Foundation Tier**Wednesday 15 January 2014 – Morning
Time: 2 hours

Paper Reference

4MA0/2FR**You must have:**

Ruler graduated in centimetres and millimetres, protractor, compasses, pen, HB pencil, eraser, calculator. Tracing paper may be used.

Total Marks

Instructions

- Use **black** ink or ball-point pen.
- **Fill in the boxes** at the top of this page with your name, centre number and candidate number.
- Answer **all** questions.
- Without sufficient working, correct answers may be awarded no marks.
- Answer the questions in the spaces provided
– *there may be more space than you need.*
- **Calculators may be used.**
- You must **NOT** write anything on the formulae page.
Anything you write on the formulae page will gain NO credit.

Information

- The total mark for this paper is 100.
- The marks for **each** question are shown in brackets
– *use this as a guide as to how much time to spend on each question.*

Advice

- Read each question carefully before you start to answer it.
- Check your answers if you have time at the end.

Turn over ►

P42951A

©2014 Pearson Education Ltd.

6/6/1/1/



P 4 2 9 5 1 A 0 1 2 4

PEARSON**PAPACAMBRIDGE**

International GCSE MATHEMATICS

FORMULAE SHEET – FOUNDATION TIER

Pythagoras' Theorem
 $a^2 + b^2 = c^2$

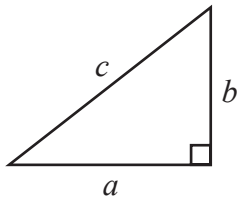

Area of a trapezium = $\frac{1}{2}(a + b)h$

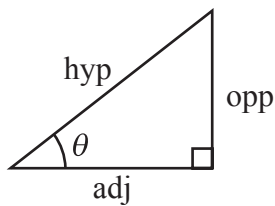
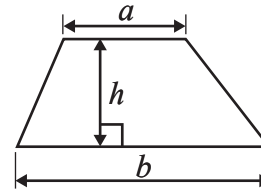

adj = hyp \times cos θ
 opp = hyp \times sin θ
 opp = adj \times tan θ

Volume of prism = area of cross section \times length

or $\sin \theta = \frac{\text{opp}}{\text{hyp}}$

$\cos \theta = \frac{\text{adj}}{\text{hyp}}$

$\tan \theta = \frac{\text{opp}}{\text{adj}}$

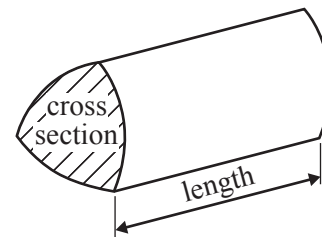

Circumference of circle = $2\pi r$

Area of circle = πr^2

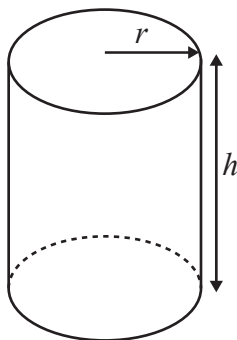

Volume of cylinder = $\pi r^2 h$

Curved surface area
 of cylinder = $2\pi r h$

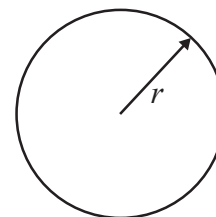

Answer ALL TWENTY ONE questions.

Write your answers in the spaces provided.

You must write down all stages in your working.

1

3	7	18	25	37	60	70
---	---	----	----	----	----	----

From the numbers in the box, write down

(a) an odd number

.....
(1)

(b) an even number

.....
(1)

(c) the square number

.....
(1)

(d) the factor of 35

.....
(1)

(e) the multiple of 12

.....
(1)

(f) two numbers which make this calculation correct.

$$\square + \square = 25$$

(1)

(Total for Question 1 is 6 marks)

Do NOT write in this space.



- 2 The diagram shows a quadrilateral on a square grid.

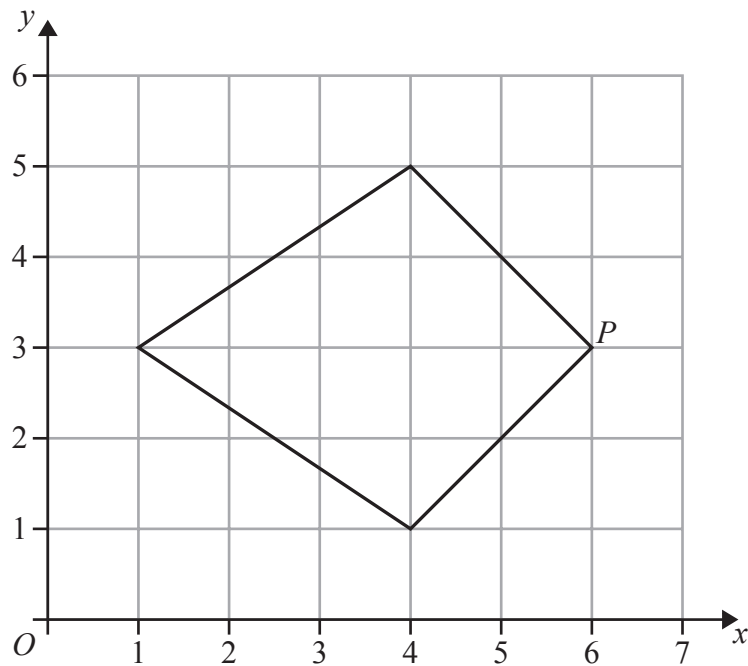

- (a) What is the mathematical name for this quadrilateral?

.....
(1)

- (b) On the quadrilateral, draw its line of symmetry.

(1)

- (c) Write down the coordinates of the point P .

(.....,)
(1)

The size of the angle at P is 90°

- (d) Write down the mathematical name for an angle of 90°

.....
(1)

(Total for Question 2 is 4 marks)

Do NOT write in this space.



- 3 The clock face shows the time in the afternoon when Rocco arrived at the train station.

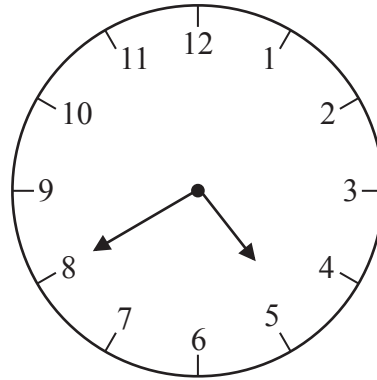

- (a) Write down this time using the 24-hour clock.

.....
(1)

Rocco's train left the station at 17 12

- (b) How many minutes is 17 12 after the time he arrived at the station?

..... minutes
(1)

Rocco's train journey took 1 hour 56 minutes.

- (c) At what time did his journey end?

Give your answer using the 24-hour clock.

.....
(2)

(Total for Question 3 is 4 marks)

Do NOT write in this space.



4 Here is a sequence of patterns made from small triangular tiles.

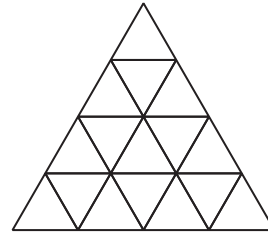
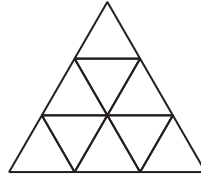
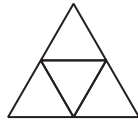

Pattern number 1

Pattern number 2

Pattern number 3

Pattern number 4

The table shows the number of tiles used to make each pattern.

Pattern number	1	2	3	4
Number of tiles	1	4	9	16

(a) How many tiles are used to make

(i) Pattern number 5

.....

(ii) Pattern number 10

.....

(2)

A pattern in the sequence is made from 144 tiles.

(b) Find the Pattern number for this pattern.

.....

(1)



(c) On the diagram below, shade $\frac{2}{3}$ of Pattern number 3.

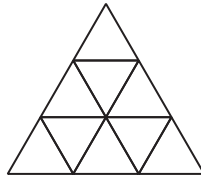

Pattern number 3

(1)

Some tiles in Pattern number 4 are shaded.

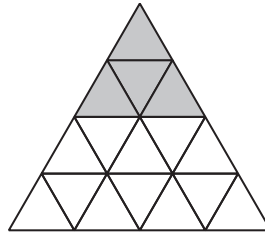

Pattern number 4

(d) What fraction of Pattern number 4 is shaded?

Give your fraction in its simplest form.

.....
(2)

(Total for Question 4 is 6 marks)

Do NOT write in this space.



5

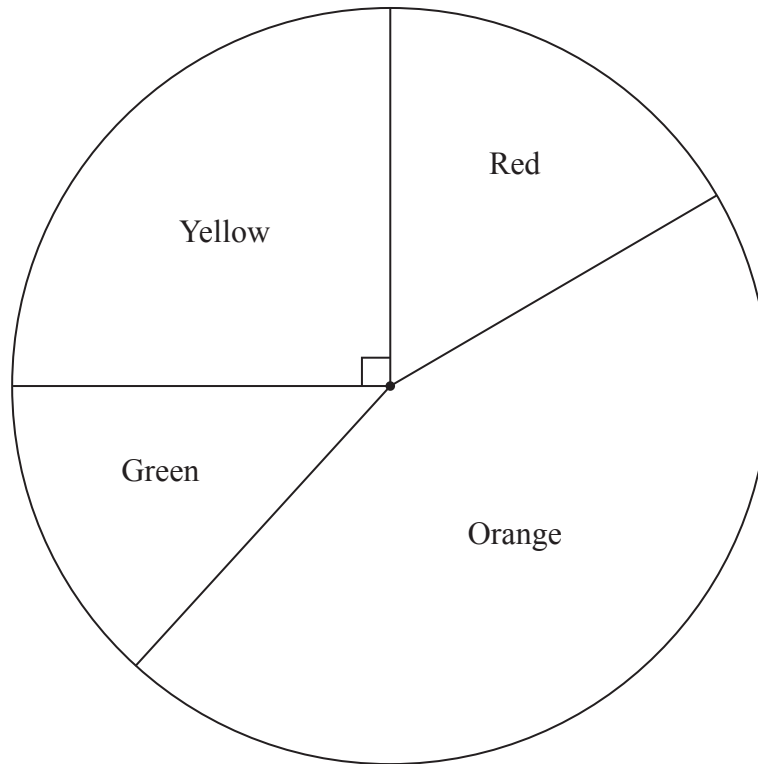

A jar contains 60 sweets.

The sweets are red or orange or green or yellow.

The number of sweets of each colour in the jar was used to draw the pie chart.

The pie chart is accurately drawn.

(a) Which colour sweet is there most of in the jar?

.....
(1)

(b) Measure the size of the angle on the pie chart for green sweets.

.....
(1)

The angle on the pie chart for yellow sweets is 90°

(c) How many of the 60 sweets in the jar are yellow?

.....
(2)



10 of the 60 sweets in the jar are red.
Billy takes at random a sweet from the jar.

(d) What is the probability that he takes a red sweet?

.....
(1)

(Total for Question 5 is 5 marks)

6 Here are five decimal numbers.

0.16 0.06 0.007 0.41 0.032

(a) Write 0.41 as a fraction.

.....
(1)

(b) Write 0.16 as a percentage.

..... %
(1)

(c) Write down the smallest of the five numbers.

.....
(1)

(Total for Question 6 is 3 marks)

Do NOT write in this space.



- 7 Some students take part in a quiz.
They all start with a score of zero.
When a student gives a correct answer, 1 point is added to the student's score.
When a student gives a wrong answer, 1 point is subtracted from the student's score.

Kasa has -4 points.

Mansi has 7 points.

- (a) How many more points has Mansi than Kasa?

.....
(1)

Malik has -3 points.

He then gives the correct answer to 14 questions and the wrong answer to 5 questions.

- (b) How many points does Malik now have?

.....
(1)

Trena has 12 points.

She gave the correct answer to 21 questions.

- (c) How many wrong answers did she give?

.....
(1)

(Total for Question 7 is 3 marks)

Do NOT write in this space.



- 8 Matthias buys a bag of Power Pup food for his dog, Rex.
The food in the bag weighs 16 kilograms.
Matthias feeds Rex 250 grams of Power Pup each day.

(a) Find the number of days for which Matthias can feed Rex from one bag of Power Pup.

.....
(3)

There are 24 grams of protein in 100 grams of Power Pup.

(b) How many grams of protein are there in 250 grams of Power Pup?

..... grams
(3)

There are 12 grams of fibre and 40 grams of fat in a daily portion of Power Pup.

(c) Write down the ratio of the weight of fibre to the weight of fat.
Give your ratio in its simplest form.

.....
(2)

(Total for Question 8 is 8 marks)



9 (a) Solve

(i) $9 + x = 27$

$$x = \dots\dots\dots$$

(ii) $6y = 18$

$$y = \dots\dots\dots$$

(2)

$$M = 2p - 4q$$

(b) Work out the value of M when $p = 10$ and $q = 2$

$$M = \dots\dots\dots$$

(2)

$$N = 5c - 4d$$

(c) Work out the value of c when $N = 18$ and $d = 3$

$$c = \dots\dots\dots$$

(3)

(Total for Question 9 is 7 marks)



10 Here are Mika's scores in nine French tests.

6 7 6 9 8 6 4 10 9

(a) Find the range of her scores.

.....
(2)

(b) Find her median score.

.....
(2)

Here are Ryan's scores in nine French tests.

4 6 4 7 8 a 6 7 7

The mean of Ryan's nine scores is 6

(c) Work out the value of a .

$a =$
(3)

(Total for Question 10 is 7 marks)

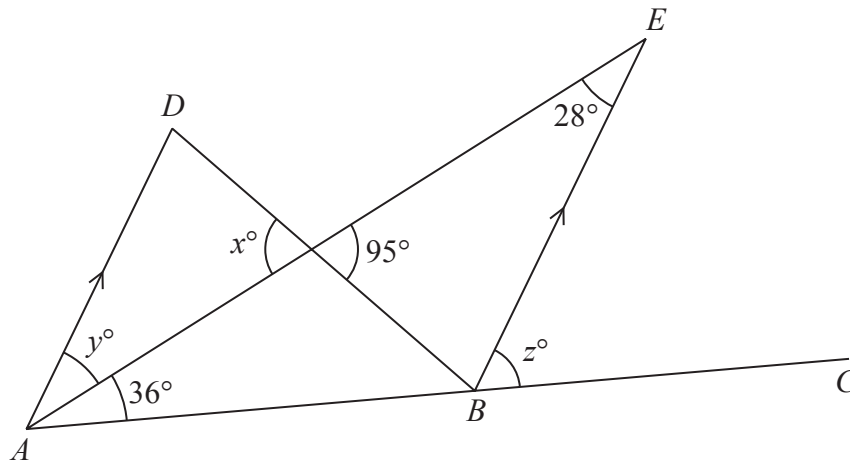

11

Diagram **NOT**
accurately drawn

ADB and AEB are triangles.
 ABC is a straight line.
 AD is parallel to BE .

(a) (i) Find the value of x .

$x = \dots\dots\dots$

(ii) Give a reason for your answer.

(2)

(b) Find the value of y .

$y = \dots\dots\dots$
(1)

(c) Find the value of z .

$z = \dots\dots\dots$
(2)

(Total for Question 11 is 5 marks)



12 Tanya goes to school by bus.

The probability that her bus arrives on time is 0.8

(a) Work out the probability that her bus does **not** arrive on time.

.....
(1)

Tanya goes to school by bus on 200 days in a year.

Each day, the probability that her bus arrives on time is 0.8

(b) Work out an estimate for the number of these 200 days that her bus arrives on time.

.....
(2)

(Total for Question 12 is 3 marks)

13 On a map, 4 centimetres represents a real distance of 1 kilometre.

On the map, the distance between two points is 14 cm.

Work out the real distance between these two points.

Give your answer in kilometres.

..... km

(Total for Question 13 is 2 marks)



- 14 Mansi left her home at 09 00 to walk to the shops. She stopped at the newspaper shop and then carried on to the fish shop. Here is the distance-time graph for Mansi's journey from her home to the fish shop.

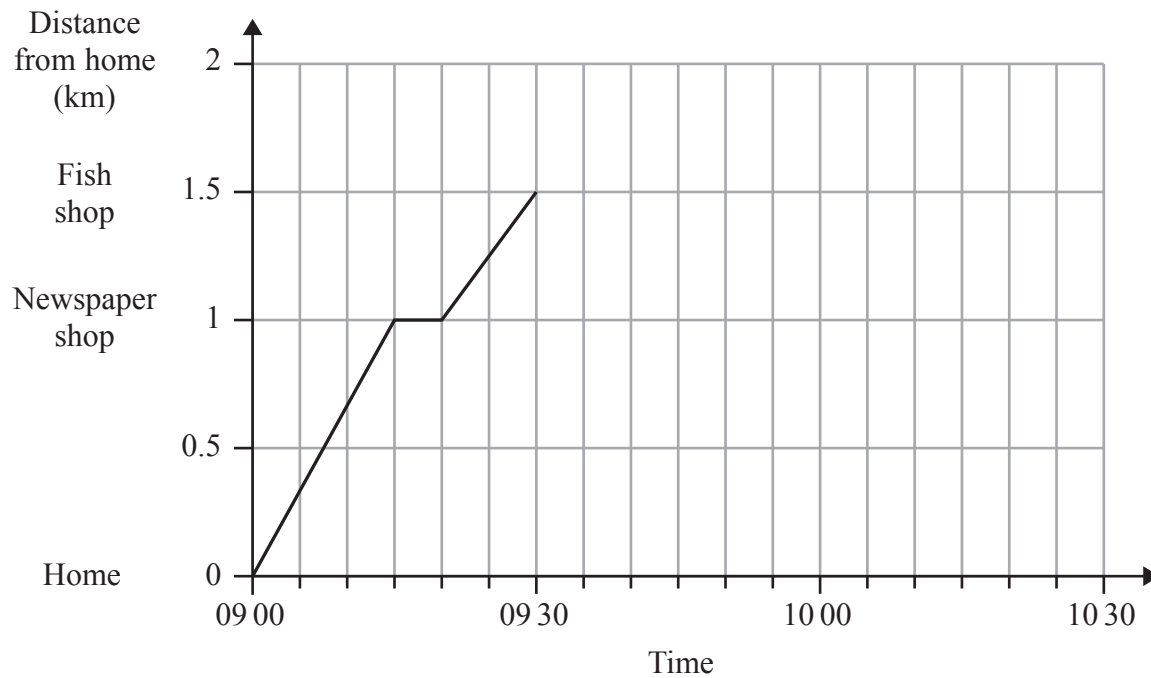

- (a) How many minutes did it take Mansi to walk from the newspaper shop to the fish shop?

..... minutes
(1)

- (b) Work out the average speed, in kilometres per hour, for Mansi's journey from her home to the newspaper shop.

..... km/h
(2)

Mansi stopped for 10 minutes in the fish shop. She then walked home at a constant speed of 3 km/h.

- (c) Show this information on the graph.

(2)

(Total for Question 14 is 5 marks)



15 The diagram shows a solid prism.

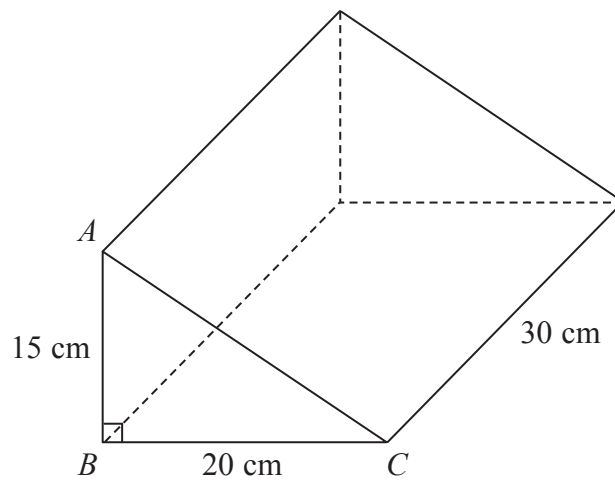

Diagram **NOT**
accurately drawn

(a) (i) How many vertices has the prism?

.....

(ii) How many edges has the prism?

.....

(2)

$AB = 15$ cm, $BC = 20$ cm and angle $ABC = 90^\circ$

(b) Work out the area of triangle ABC .

..... cm^2

(2)

The length of the prism is 30 cm.

(c) Work out the volume of the prism.

..... cm^3

(2)

(Total for Question 15 is 6 marks)



16

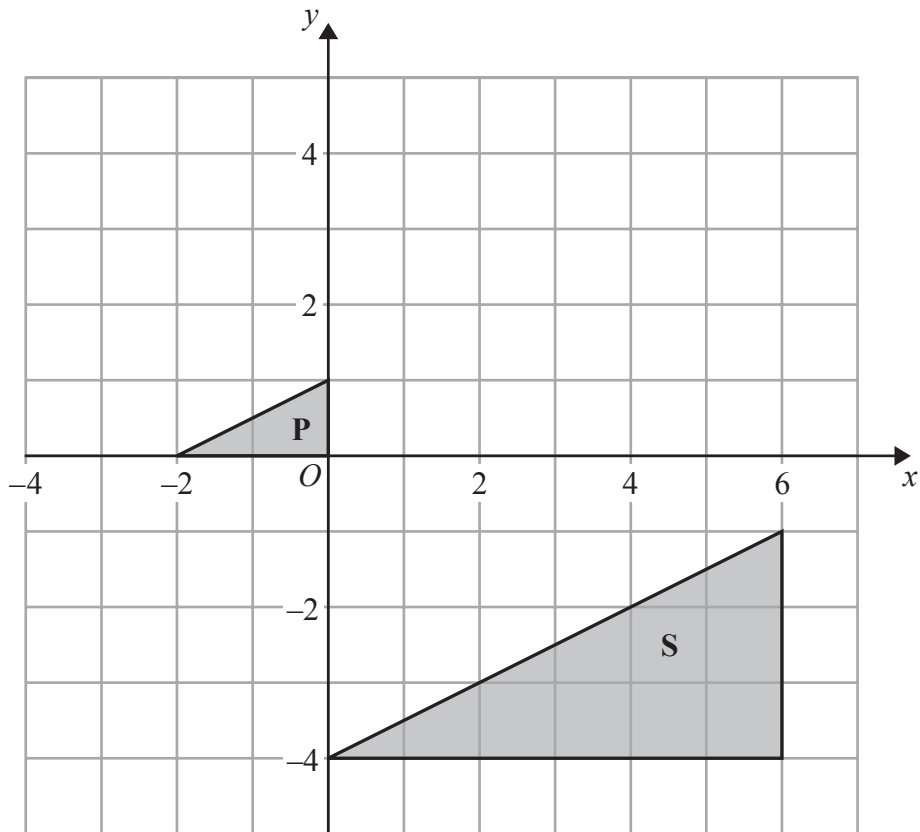

(a) On the grid, translate triangle **P** 2 squares to the right and 1 square down.

Label the new triangle **Q**.

(1)

(b) On the grid, reflect triangle **P** in the line $y = 2$

Label the new triangle **R**.

(2)

(c) Describe fully the single transformation that maps triangle **P** onto triangle **S**.

(3)

(Total for Question 16 is 6 marks)

Do NOT write in this space.

17 (a) Find the value of the cube of 4

.....
(1)

(b) Write $3 \times 3 \times 3 \times 3 \times 3$ as a single power of 3

.....
(1)

(c) Write $\frac{7^5 \times 7^9}{7^6}$ as a single power of 7

.....
(2)

(Total for Question 17 is 4 marks)

18 (a) Show that $\frac{4}{5} + \frac{2}{3} = 1\frac{7}{15}$

(2)

(b) Show that $2\frac{1}{4} \div 3\frac{1}{2} = \frac{9}{14}$

(3)

(Total for Question 18 is 5 marks)



19 Loma grows tomatoes in her garden.

The table shows information about the weights, in grams, of some of her tomatoes.

Weight of tomato (w grams)	Number of tomatoes
$0 < w \leq 10$	2
$10 < w \leq 20$	8
$20 < w \leq 30$	16
$30 < w \leq 40$	10
$40 < w \leq 50$	4

Work out an estimate for the total weight of these tomatoes.

..... grams

(Total for Question 19 is 3 marks)

20 Use ruler and compasses to construct the bisector of angle ABC .

You must show all of your construction lines.

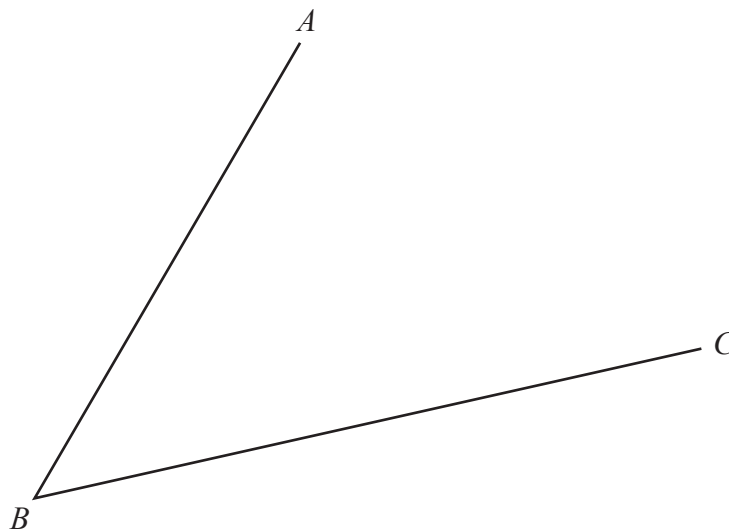

(Total for Question 20 is 2 marks)



21 (a) Complete the table of values for $2x + y = 4$

x	-1	2	4
y			

(2)

(b) On the grid, draw the graph of $2x + y = 4$ for values of x from -1 to 4

(2)

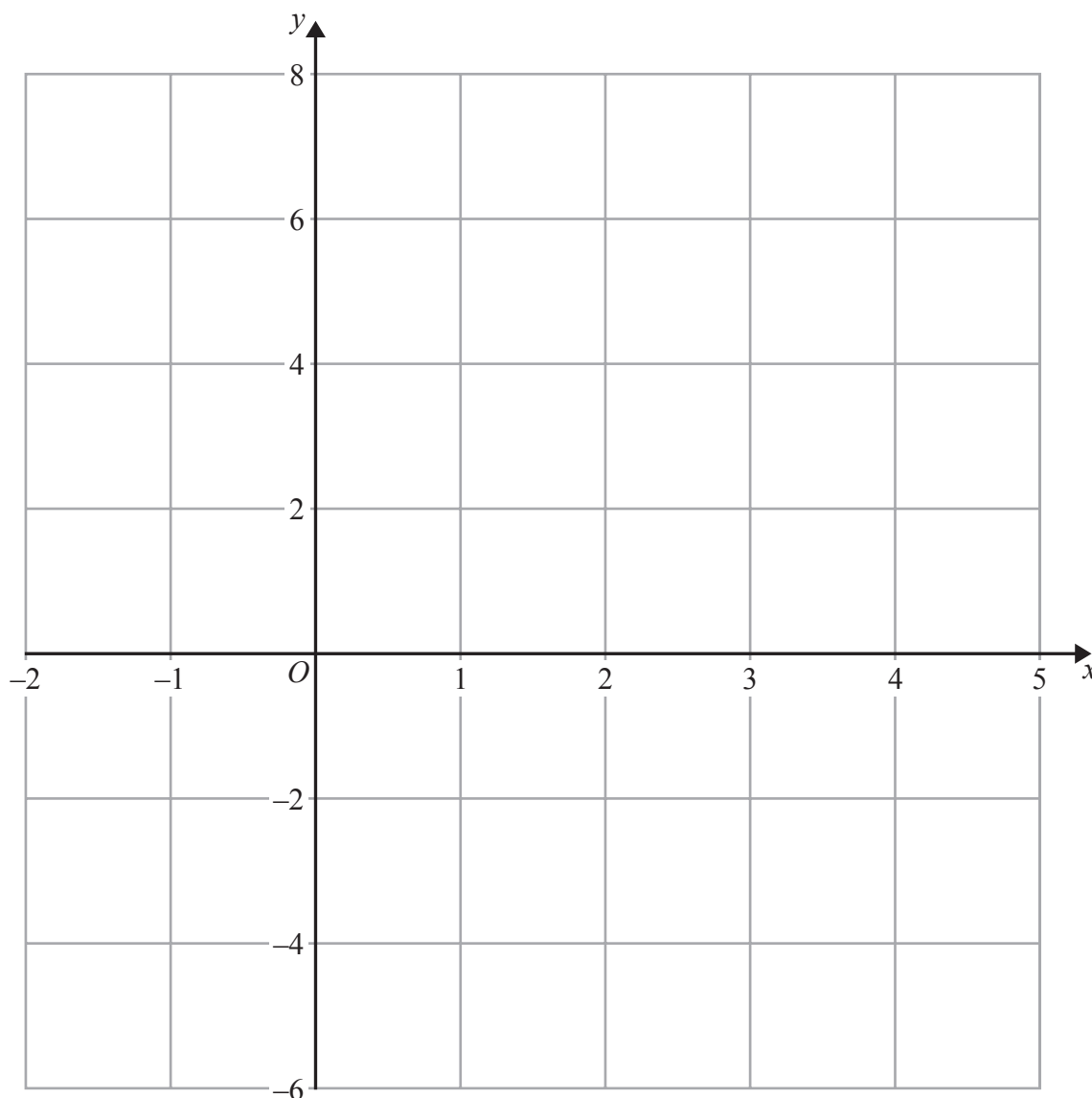

(c) Show, by shading on the grid, the region which satisfies **all three** of the inequalities

$$x \geq -1, \quad y \geq 2 \quad \text{and} \quad 2x + y \leq 4$$

Label the region **R**.

(2)

(Total for Question 21 is 6 marks)

TOTAL FOR PAPER IS 100 MARKS



BLANK PAGE

Do NOT write on this page.



BLANK PAGE

Do NOT write on this page.



BLANK PAGE

Do NOT write on this page.

