

Write your name here

Surname

Other names

Pearson Edexcel Certificate
Pearson Edexcel
International GCSE

Centre Number

--	--	--	--	--

Candidate Number

--	--	--	--

Mathematics A

Paper 1F



Foundation Tier

Thursday 26 May 2016 – Morning
Time: 2 hours

Paper Reference

4MA0/1F
KMA0/1F

You must have:

Ruler graduated in centimetres and millimetres, protractor, compasses, pen, HB pencil, eraser, calculator. Tracing paper may be used.

Total Marks

Instructions

- Use **black** ink or ball-point pen.
- **Fill in the boxes** at the top of this page with your name, centre number and candidate number.
- Answer **all** questions.
- Without sufficient working, correct answers may be awarded no marks.
- Answer the questions in the spaces provided
– *there may be more space than you need.*
- **Calculators may be used.**
- You must **NOT** write anything on the formulae page.
Anything you write on the formulae page will gain NO credit.

Information

- The total mark for this paper is 100.
- The marks for **each** question are shown in brackets
– *use this as a guide as to how much time to spend on each question.*

Advice

- Read each question carefully before you start to answer it.
- Check your answers if you have time at the end.

Turn over ►

P45862A

©2016 Pearson Education Ltd.

1/1/1/1/

PEARSON
PAPACAMBRIDGE

International GCSE MATHEMATICS

FORMULAE SHEET – FOUNDATION TIER

Pythagoras' Theorem
 $a^2 + b^2 = c^2$

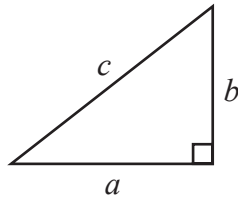

Area of a trapezium = $\frac{1}{2}(a + b)h$

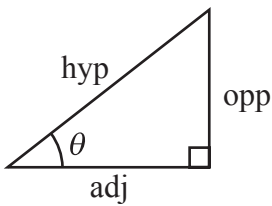
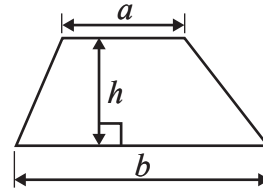

adj = hyp \times cos θ
 opp = hyp \times sin θ
 opp = adj \times tan θ

Volume of prism = area of cross section \times length

or $\sin \theta = \frac{\text{opp}}{\text{hyp}}$

$\cos \theta = \frac{\text{adj}}{\text{hyp}}$

$\tan \theta = \frac{\text{opp}}{\text{adj}}$

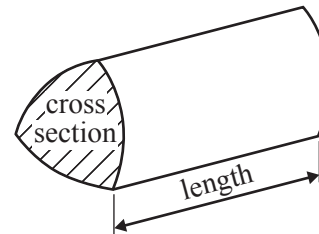

Circumference of circle = $2\pi r$

Area of circle = πr^2

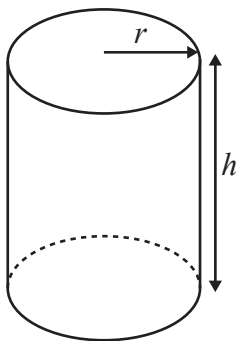

Volume of cylinder = $\pi r^2 h$

Curved surface area
 of cylinder = $2\pi r h$

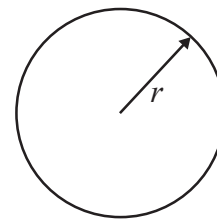

DO NOT WRITE IN THIS AREA

DO NOT WRITE IN THIS AREA

DO NOT WRITE IN THIS AREA



Answer ALL NINETEEN questions.

Write your answers in the spaces provided.

You must write down all the stages in your working.

1 There are 3708 people at a football match.

(a) Write the number 3708 in words.

.....
(1)

(b) Write the number 3708 correct to the nearest thousand.

.....
(1)

2934 of the 3708 people are adults.
The rest of the people are children.

(c) How many children are at the football match?

.....
(1)

24 buses took people to the football match.
4 of these buses came from London.

(d) What fraction of the buses came from London?
Give your fraction in its simplest form.

.....
(2)

There are 48 seats on one bus.

$\frac{1}{8}$ of the seats on this bus are empty.

(e) How many seats are **not** empty?

.....
(2)

(Total for Question 1 is 7 marks)

DO NOT WRITE IN THIS AREA

DO NOT WRITE IN THIS AREA

DO NOT WRITE IN THIS AREA







P

PAPACAMBRIDGE



4

- 2 The pictogram shows information about the number of emails Michael sent each day from Monday to Friday.

Monday	
Tuesday	
Wednesday	
Thursday	
Friday	
Saturday	

 represents 4 emails

- (a) How many emails did Michael send on Monday?

.....
(1)

The number of emails Michael received on Thursday was 10 more than the number of emails he sent on Thursday.

- (b) How many emails did Michael receive on Thursday?

.....
(2)

Michael sent 10 emails on Saturday.

- (c) Show this information on the pictogram.

(1)

(Total for Question 2 is 4 marks)

DO NOT WRITE IN THIS AREA

DO NOT WRITE IN THIS AREA

DO NOT WRITE IN THIS AREA



- 3 The diagram shows two quadrilaterals and a triangle on a square grid.

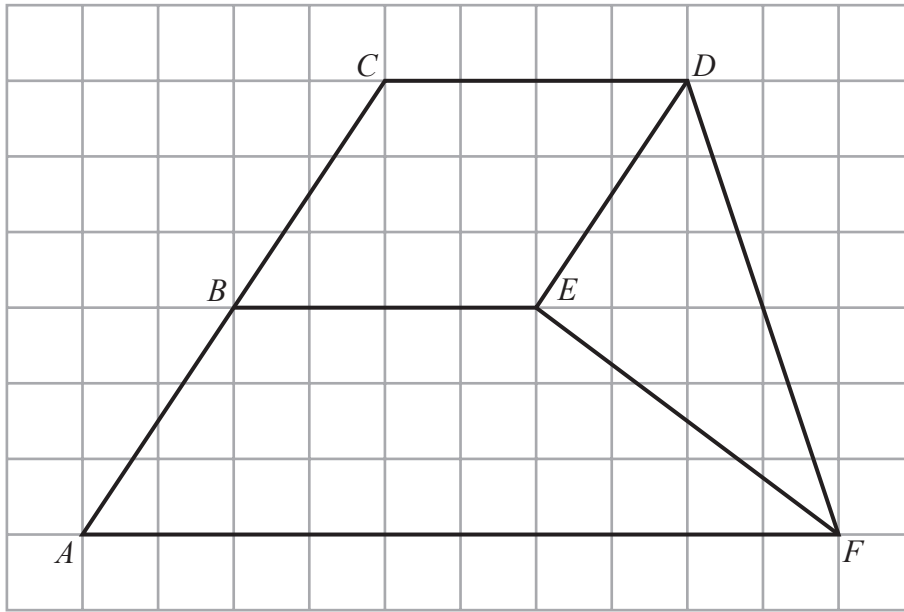

- (a) Measure the length of DF .
State the units of your answer.

.....
(2)

- (b) On the diagram, mark with arrows (\gg) a pair of parallel lines.

(1)

- (c) Write down the mathematical name of quadrilateral $ABEF$.

.....
(1)

- (d) On the diagram, mark an obtuse angle with the letter O .

(1)

(Total for Question 3 is 5 marks)



4 Write down all the factors of 40

.....
(Total for Question 4 is 2 marks)

5 (a) Change 8 metres into centimetres.

..... centimetres
(1)

(b) Change 9600 grams into kilograms.

..... kilograms
(1)

Jamil has 5 litres of water in a container.
He pours 750 millilitres of water into each of 6 bottles.

(c) How much water is left in the container?
Give your answer in millilitres.

..... millilitres
(3)

(Total for Question 5 is 5 marks)

DO NOT WRITE IN THIS AREA

DO NOT WRITE IN THIS AREA

DO NOT WRITE IN THIS AREA



6 (a) Here is a probability scale.

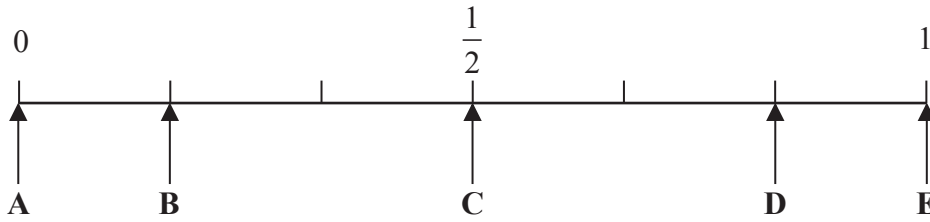

A fair 6-sided dice is thrown.

Write down the letter of the arrow that points to the probability that the dice lands on

(i) the number 5

.....

(ii) a number greater than 10

.....

(iii) an even number.

.....

(3)

Alice says that the probability it will rain tomorrow is 1.2
She **cannot** be right.

(b) Explain why.

.....
(1)

Brett has a bag of counters and a box of counters.

1 red counter, 1 white counter, 1 blue counter and 1 yellow counter are in the bag.
1 green counter and 1 purple counter are in the box.

Brett takes at random a counter from the bag.
He then takes at random a counter from the box.

(c) (i) List all the possible combinations of coloured counters he could get.

.....
.....
.....

(ii) Write down the probability that Brett takes a red counter and a green counter.

.....

(3)

(Total for Question 6 is 7 marks)

DO NOT WRITE IN THIS AREA

DO NOT WRITE IN THIS AREA

DO NOT WRITE IN THIS AREA



- 7 (a) Shade 70% of this shape.

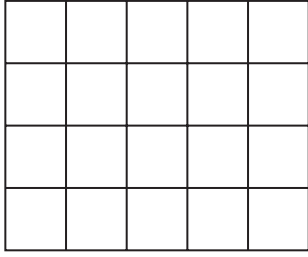

(1)

- (b) Write 23% as a fraction.

.....
(1)

- (c) Write 6% as a decimal.

.....
(1)

14% of the workers in a factory work part time.

- (d) What percentage of the workers in the factory do **not** work part time?

..... %
(1)

- (e) Work out 14% of 350

.....
(2)

(Total for Question 7 is 6 marks)

DO NOT WRITE IN THIS AREA

DO NOT WRITE IN THIS AREA

DO NOT WRITE IN THIS AREA



8 (a) Solve $4e = 20$

$$e = \dots\dots\dots (1)$$

(b) Solve $15 - f = 9$

$$f = \dots\dots\dots (1)$$

(c) Simplify $5m + 4p - 2m + 7p$

$$\dots\dots\dots (2)$$

There are 4 pens in each small box of pens.
There are 10 pens in each large box of pens.

Harry buys x small boxes of pens and y large boxes of pens.

(d) Write down an expression, in terms of x and y , for the total number of pens Harry buys.

$$\dots\dots\dots (2)$$

$a = -5$

$c = -2$

(e) Work out the value of $2a^2 + 6c$

$$\dots\dots\dots (2)$$

(Total for Question 8 is 8 marks)

DO NOT WRITE IN THIS AREA

DO NOT WRITE IN THIS AREA

DO NOT WRITE IN THIS AREA



9 Here are six quadrilaterals.

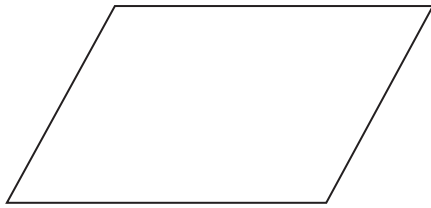

A

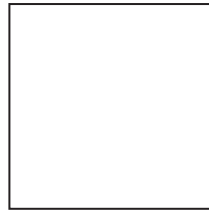

B

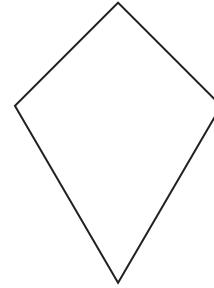

C

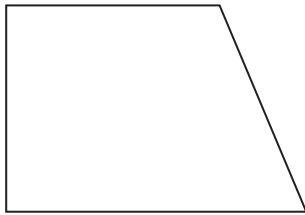

D

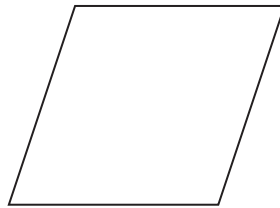

E



F

(a) Write down the mathematical name for quadrilateral C.

.....
(1)

Two of the quadrilaterals have **no** lines of symmetry.

(b) Write down the letters of these two quadrilaterals.

..... and
(2)

Two of the quadrilaterals have 2 lines of symmetry **and** rotational symmetry of order 2

(c) Write down the letters of these two quadrilaterals.

..... and
(2)

DO NOT WRITE IN THIS AREA

DO NOT WRITE IN THIS AREA

DO NOT WRITE IN THIS AREA



DO NOT WRITE IN THIS AREA

DO NOT WRITE IN THIS AREA

DO NOT WRITE IN THIS AREA

(d) On the grid, reflect the shaded shape in the mirror line.

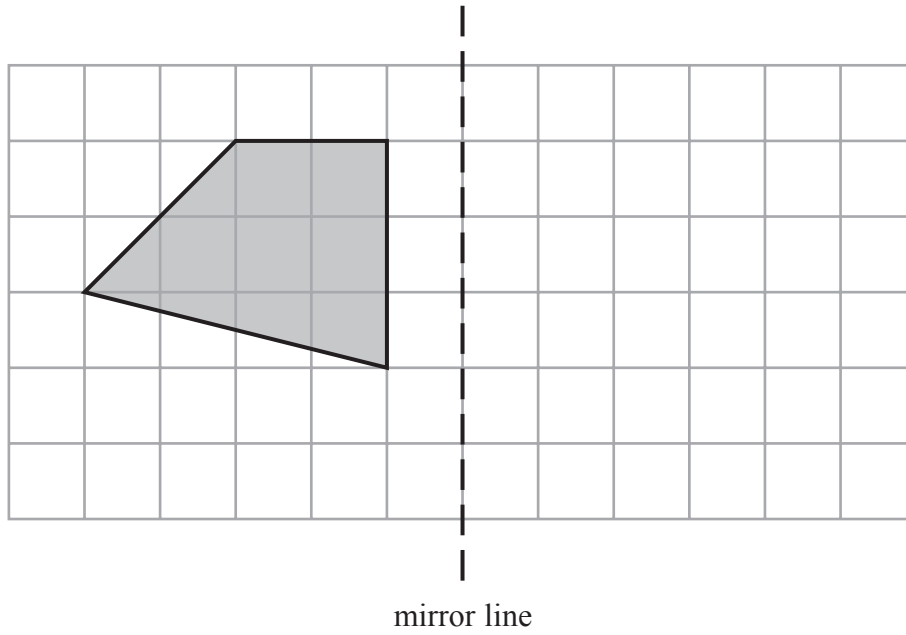

(1)

Here is a different quadrilateral.

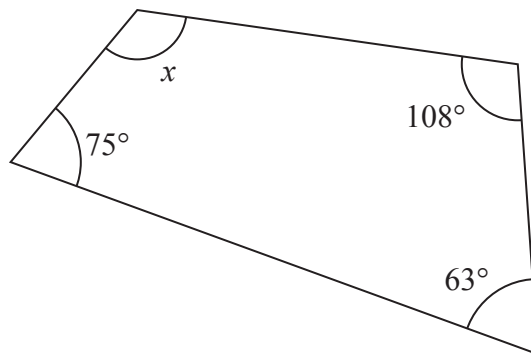

Diagram **NOT** accurately drawn

(e) Work out the size of the angle marked x .

(2)

(Total for Question 9 is 8 marks)



- 10 Kevin left his home at 1000 to cycle to a lake. On the way, he stopped at a friend's house and then continued his journey to the lake. Here is the distance-time graph for his journey to the lake.

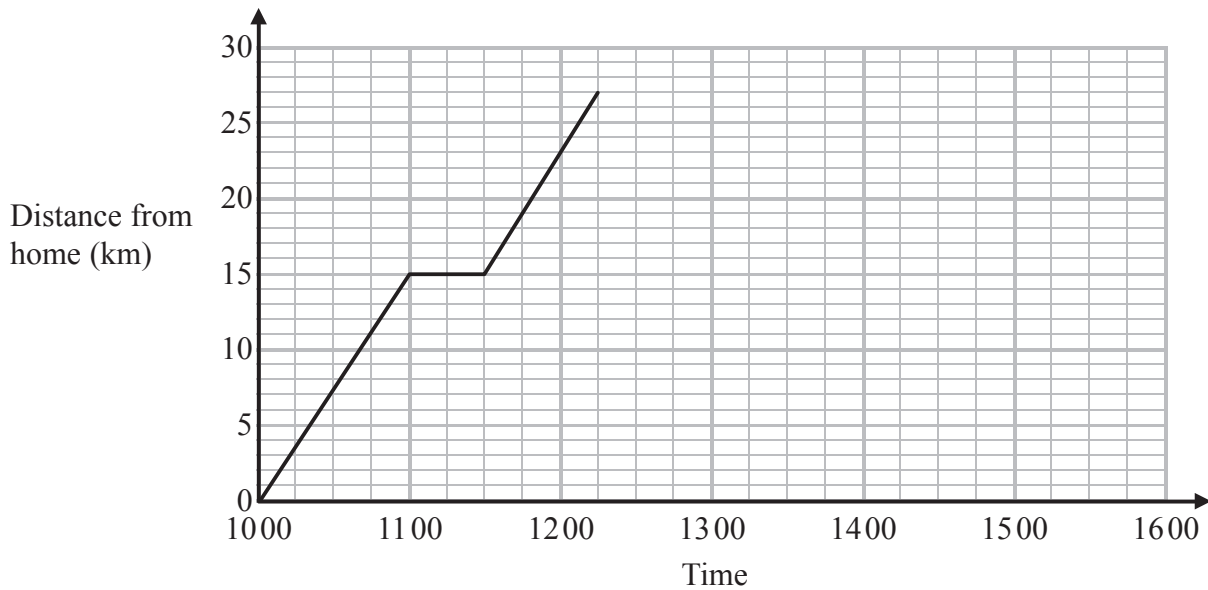

- (a) For how many minutes did Kevin stop at his friend's house?

..... minutes
(1)

- (b) How far is the lake from Kevin's home?

..... km
(1)

Kevin stayed at the lake until 13 15

He then cycled, without stopping, at a constant speed from the lake back to his home.

It took Kevin $1\frac{1}{4}$ hours to cycle home.

- (c) (i) Show all this information on the graph.

- (ii) Work out Kevin's speed as he cycled from the lake back to his home.

..... km/h
(4)

(Total for Question 10 is 6 marks)

DO NOT WRITE IN THIS AREA

DO NOT WRITE IN THIS AREA

DO NOT WRITE IN THIS AREA



- 11 The table shows information about the number of visits each of 40 adults made to the gym last week.

Number of visits to the gym	Frequency
0	4
1	3
2	12
3	5
4	8
5	5
6	2
7	1

- (a) Write down the mode of the number of visits to the gym.

.....
(1)

- (b) Find the median of the number of visits to the gym.

.....
(2)

- (c) Work out the mean of the number of visits to the gym.

.....
(3)

One of these adults is chosen at random.

- (d) Write down the probability that this adult made more than 5 visits to the gym last week.

.....
(2)

(Total for Question 11 is 8 marks)

DO NOT WRITE IN THIS AREA

DO NOT WRITE IN THIS AREA

DO NOT WRITE IN THIS AREA



P 4

PAPACAMBRIDGE



2 4

12 $A = \{2, 4, 6, 8, 10, 12, 14\}$
 $B = \{1, 3, 5, 7, 9, 11, 13\}$
 $C = \{3, 6, 9, 12\}$

(a) Complete the following sentence.

All the numbers in set C are of 3 (1)

(b) List the members of the set

(i) $A \cap C$

.....

(ii) $A \cup C$

.....

(2)

(c) Explain why $A \cap B = \emptyset$

.....

(1)

(Total for Question 12 is 4 marks)

DO NOT WRITE IN THIS AREA

DO NOT WRITE IN THIS AREA

DO NOT WRITE IN THIS AREA



13 Here are the ingredients needed to make 12 muffins.

Ingredients to make 12 muffins
300 g flour
150 g sugar
250 ml milk
100 g butter
2 eggs

Sarah makes 60 muffins.

(a) Work out how much sugar she uses.

..... 00
(2)

James makes some muffins.
He uses 625 ml of milk.

(b) How many muffins did he make?

.....
(2)

(Total for Question 13 is 4 marks)

DO NOT WRITE IN THIS AREA

DO NOT WRITE IN THIS AREA

DO NOT WRITE IN THIS AREA



P 4

PAPACAMBRIDGE



2 4

14 On the grid, draw the graph of $y = 3x - 5$ for values of x from -2 to 3

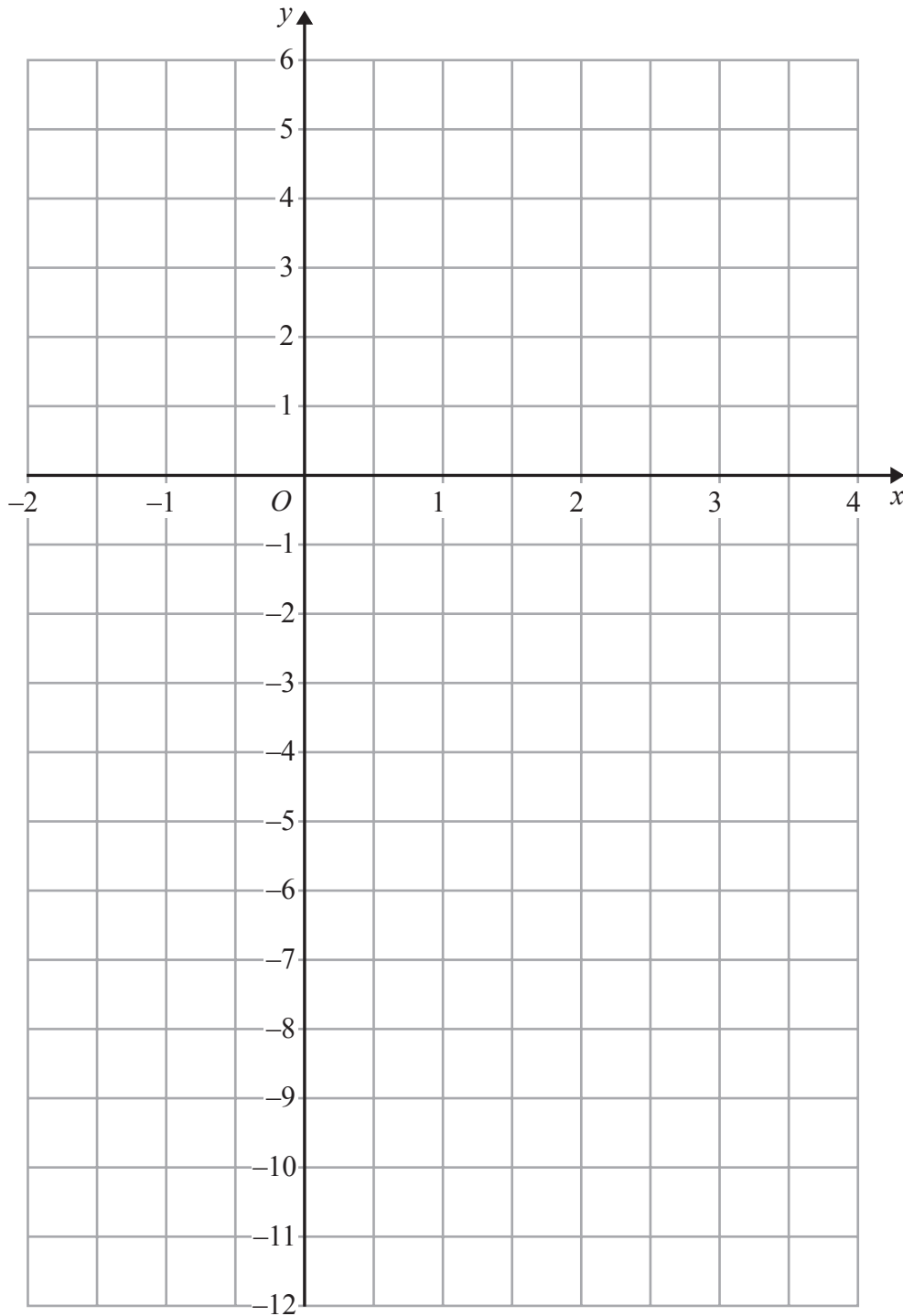

(Total for Question 14 is 4 marks)

DO NOT WRITE IN THIS AREA

DO NOT WRITE IN THIS AREA

DO NOT WRITE IN THIS AREA



15 (a) Show that $\frac{3}{10} + \frac{2}{15} = \frac{13}{30}$

(2)

(b) Show that $2\frac{5}{8} \div 1\frac{1}{6} = 2\frac{1}{4}$

(3)

(Total for Question 15 is 5 marks)

DO NOT WRITE IN THIS AREA

DO NOT WRITE IN THIS AREA

DO NOT WRITE IN THIS AREA



16 (a) Factorise $3y^2 + 2y$

.....
(1)

(b) Expand and simplify $(x - 9)(x + 2)$

.....
(2)

(c) (i) Solve $6k + 5 < 20$

(ii) n is an integer and $6n + 5 < 20$

Write down the largest possible value of n

.....
(3)

(Total for Question 16 is 6 marks)

DO NOT WRITE IN THIS AREA

DO NOT WRITE IN THIS AREA

DO NOT WRITE IN THIS AREA



17

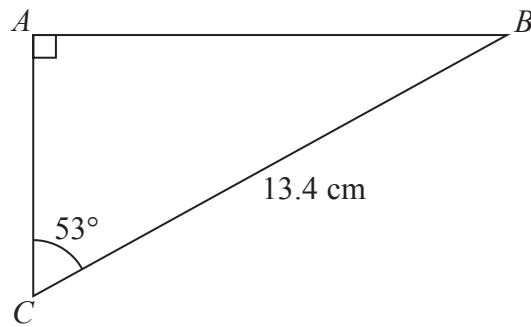

Diagram **NOT**
accurately drawn

Work out the length of AB .
Give your answer correct to 1 decimal place.

..... cm

(Total for Question 17 is 3 marks)

DO NOT WRITE IN THIS AREA

DO NOT WRITE IN THIS AREA

DO NOT WRITE IN THIS AREA



P 4

PAPACAMBRIDGE



2 4

18 Bhavin, Max and Imran share 6000 rupees in the ratios 2 : 3 : 7

Imran then gives $\frac{3}{5}$ of his share of the money to Bhavin.

What percentage of the 6000 rupees does Bhavin now have?

Give your answer correct to the nearest whole number.

DO NOT WRITE IN THIS AREA

DO NOT WRITE IN THIS AREA

DO NOT WRITE IN THIS AREA

..... %

(Total for Question 18 is 5 marks)



19 The diagram shows a circle inside a rectangle.

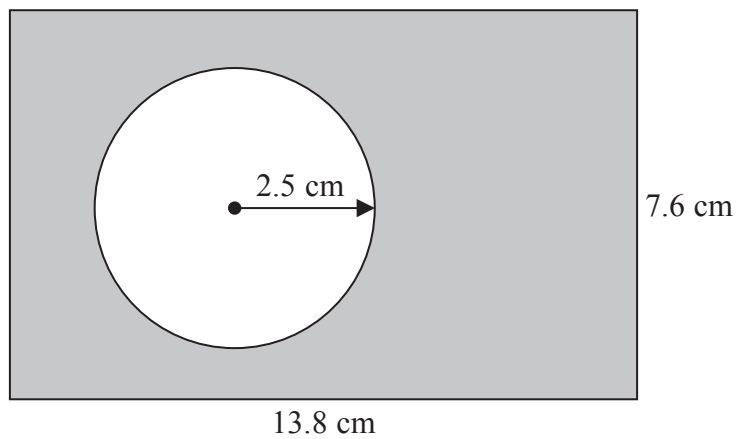

Diagram **NOT**
accurately drawn

Work out the area of the shaded region.
Give your answer correct to 3 significant figures.

..... cm²

(Total for Question 19 is 3 marks)

TOTAL FOR PAPER IS 100 MARKS



DO NOT WRITE IN THIS AREA

DO NOT WRITE IN THIS AREA

DO NOT WRITE IN THIS AREA

BLANK PAGE



DO NOT WRITE IN THIS AREA

DO NOT WRITE IN THIS AREA

DO NOT WRITE IN THIS AREA

BLANK PAGE



DO NOT WRITE IN THIS AREA

DO NOT WRITE IN THIS AREA

DO NOT WRITE IN THIS AREA

BLANK PAGE

