

Write your name here

Surname

Other names

Pearson Edexcel Certificate
Pearson Edexcel
International GCSE

Centre Number

--	--	--	--	--	--

Candidate Number

--	--	--	--	--

Mathematics A

Paper 4H

**Higher Tier**

Wednesday 15 January 2014 – Morning
Time: 2 hours

Paper Reference
4MA0/4H
KMA0/4H

You must have:

Ruler graduated in centimetres and millimetres, protractor, compasses, pen, HB pencil, eraser, calculator. Tracing paper may be used.

Total Marks

Instructions

- Use **black** ink or ball-point pen.
- **Fill in the boxes** at the top of this page with your name, centre number and candidate number.
- Answer **all** questions.
- Without sufficient working, correct answers may be awarded no marks.
- Answer the questions in the spaces provided
– *there may be more space than you need.*
- **Calculators may be used.**
- You must **NOT** write anything on the formulae page.
Anything you write on the formulae page will gain NO credit.

Information

- The total mark for this paper is 100.
- The marks for **each** question are shown in brackets
– *use this as a guide as to how much time to spend on each question.*

Advice

- Read each question carefully before you start to answer it.
- Check your answers if you have time at the end.

Turn over ►

P42941A

©2014 Pearson Education Ltd.

5/6/6/1/

**PEARSON**

**International GCSE MATHEMATICS
FORMULAE SHEET – HIGHER TIER**

Pythagoras' Theorem

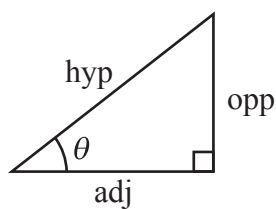
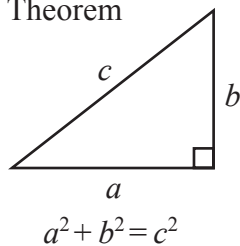

$$\begin{aligned} \text{adj} &= \text{hyp} \times \cos \theta \\ \text{opp} &= \text{hyp} \times \sin \theta \\ \text{opp} &= \text{adj} \times \tan \theta \end{aligned}$$

$$\text{or } \sin \theta = \frac{\text{opp}}{\text{hyp}}$$

$$\cos \theta = \frac{\text{adj}}{\text{hyp}}$$

$$\tan \theta = \frac{\text{opp}}{\text{adj}}$$

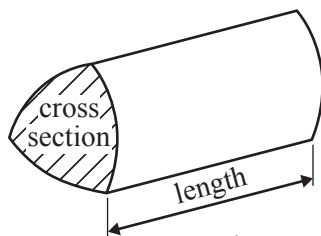

Volume of prism = area of cross section \times length

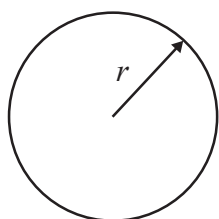

Circumference of circle = $2\pi r$

Area of circle = πr^2

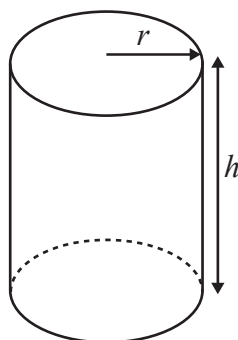

Volume of cylinder = $\pi r^2 h$

Curved surface area of cylinder = $2\pi r h$

Volume of cone = $\frac{1}{3}\pi r^2 h$

Curved surface area of cone = $\pi r l$

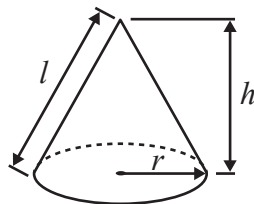

Volume of sphere = $\frac{4}{3}\pi r^3$

Surface area of sphere = $4\pi r^2$

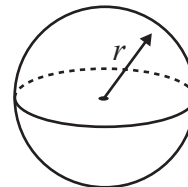

In any triangle ABC

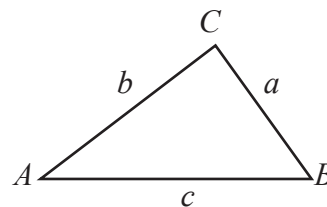

Sine rule: $\frac{a}{\sin A} = \frac{b}{\sin B} = \frac{c}{\sin C}$

Cosine rule: $a^2 = b^2 + c^2 - 2bc \cos A$

Area of triangle = $\frac{1}{2} ab \sin C$

Area of a trapezium = $\frac{1}{2}(a + b)h$

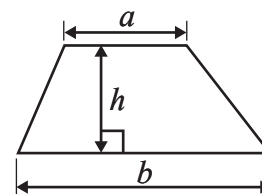

The Quadratic Equation
The solutions of $ax^2 + bx + c = 0$,
where $a \neq 0$, are given by

$$x = \frac{-b \pm \sqrt{b^2 - 4ac}}{2a}$$



Answer ALL TWENTY THREE questions.

Write your answers in the spaces provided.

You must write down all the stages in your working.

1 A school has 840 pupils and 40 teachers.

- (a) Find the ratio of the number of pupils to the number of teachers.
Give your ratio in the form $n : 1$

..... : 1
(2)

In Year 11 at the school, the ratio of the number of pupils who study Chemistry to the number of pupils who study Physics is 3 : 2

- (b) 105 pupils in Year 11 study Chemistry.
Work out the number of pupils in Year 11 who study Physics.

.....
(2)

For the 105 pupils who study Chemistry, the ratio of the number of boys to the number of girls is 4 : 3

- (c) Work out the number of girls in Year 11 who study Chemistry.

.....
(2)

(Total for Question 1 is 6 marks)

Do NOT write in this space.



2

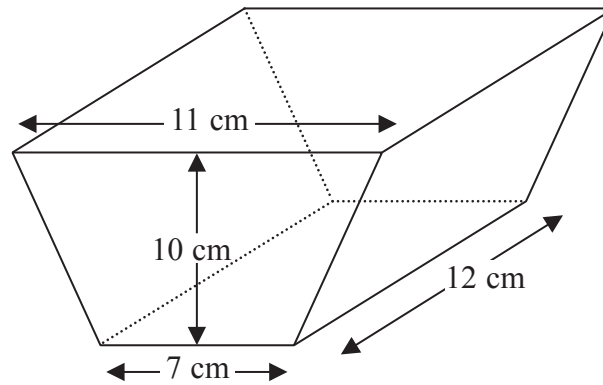

Diagram **NOT**
accurately drawn

The diagram shows a solid prism.
 The cross section of the prism is a trapezium.
 The lengths of the parallel sides of the trapezium are 11 cm and 7 cm.
 The perpendicular distance between the parallel sides of the trapezium is 10 cm.
 The length of the prism is 12 cm.

(a) Work out the area of the trapezium.

..... cm²
(2)

(b) Work out the volume of the prism.

..... cm³
(2)

(Total for Question 2 is 4 marks)

Do NOT write in this space.



- 3 Solve $6(3y + 5) = 39$
Show clear algebraic working.

$y = \dots\dots\dots$

(Total for Question 3 is 3 marks)

- 4 The table gives information about the numbers of goals scored by a football team in 30 matches.

Number of goals scored	Frequency
0	2
1	10
2	7
3	6
4	3
5	2

Find the mean number of goals scored.

(Total for Question 4 is 3 marks)

Do NOT write in this space.



5 The diagram shows a shape **P**, and a shape **Q**.

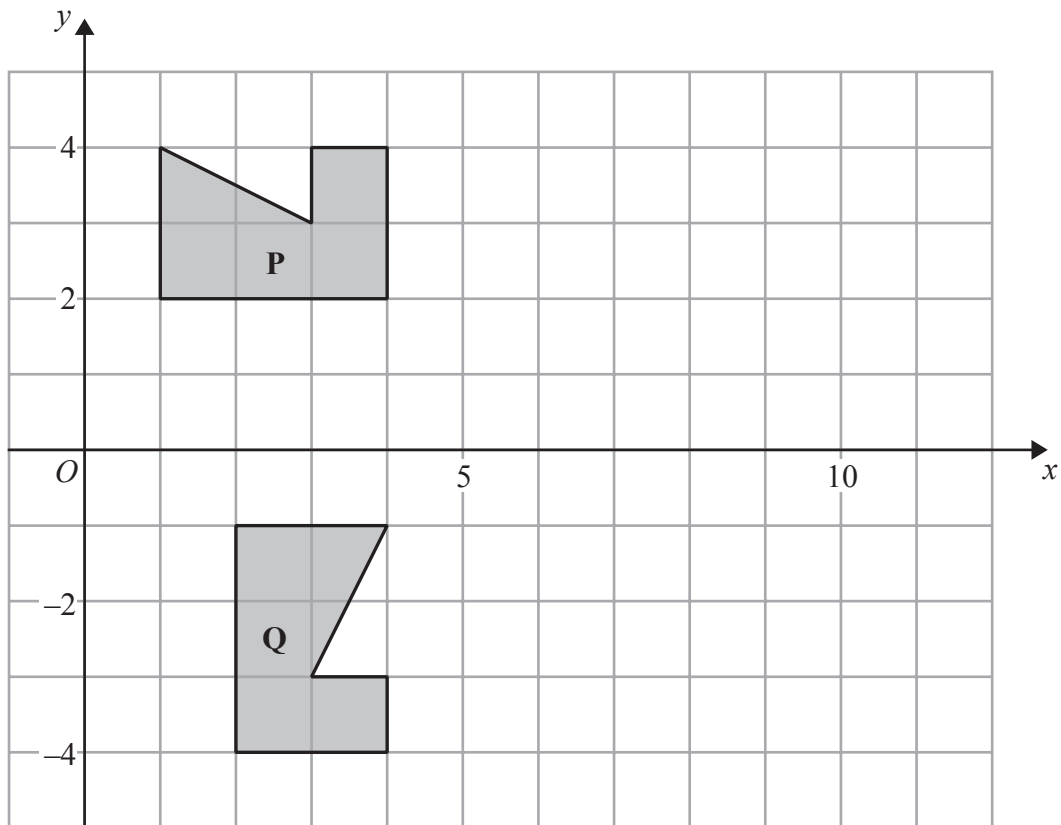

Describe fully the single transformation which maps shape **P** onto shape **Q**.

.....

.....

(Total for Question 5 is 3 marks)

Do NOT write in this space.



6 (a) Simplify $k \times k \times k \times k \times k$

.....
(1)

(b) Expand $2(7t - 3)$

.....
(1)

(c) Expand and simplify fully

(i) $4(2y + 6) - 3(2y - 7)$

(ii) $(x - 6)(x - 4)$

.....
(4)

(d) Simplify fully $\frac{v^4 \times v^7}{v^5}$

.....
(2)

(Total for Question 6 is 8 marks)

Do NOT write in this space.



- 7 A square hole is cut from a circular piece of card.

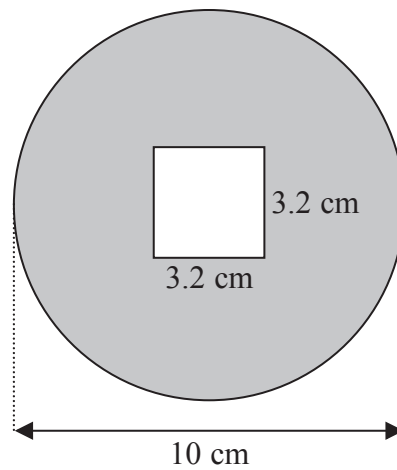

Diagram **NOT**
accurately drawn

The square has sides of length 3.2 cm.
The diameter of the circular piece of card is 10 cm.

Work out the area of the shaded region.
Give your answer correct to 3 significant figures.

..... cm²

(Total for Question 7 is 4 marks)

- 8 Express 825 as a product of its prime factors.

.....

(Total for Question 8 is 3 marks)



- 9 $\mathcal{E} = \{\text{positive whole numbers less than } 13\}$
 $A = \{\text{even numbers}\}$
 $B = \{\text{multiples of } 3\}$
 $C = \{\text{prime numbers}\}$

(a) List the members of the set

(i) $A \cap B$

.....

(ii) $B \cup C$

.....

(2)

(b) Is it true that $14 \in A$?

Tick (\checkmark) the appropriate box.

Yes

No

Explain your answer.

.....

(1)

(Total for Question 9 is 3 marks)

- 10 The mean of four numbers is 2.6
 One of the four numbers is 5

Find the mean of the other three numbers.

.....

(Total for Question 10 is 3 marks)

Do NOT write in this space.



11 The table shows the land areas, in km^2 , of four countries.

Country	Land area (km^2)
Ethiopia	1.13×10^6
Algeria	2.38×10^6
Nigeria	9.24×10^5
Kenya	5.83×10^5

(a) Which country has the largest land area?

.....
(1)

(b) Calculate the total land area, in km^2 , of all four countries.
Give your answer in standard form.

..... km^2
(2)

Population density is calculated by the formula

$$\text{Population density} = \text{Population} \div \text{Land area}$$

(c) In one year, the population of Ethiopia was 7.91×10^7
Calculate the population density of Ethiopia for that year.

..... people / km^2
(2)

(Total for Question 11 is 5 marks)

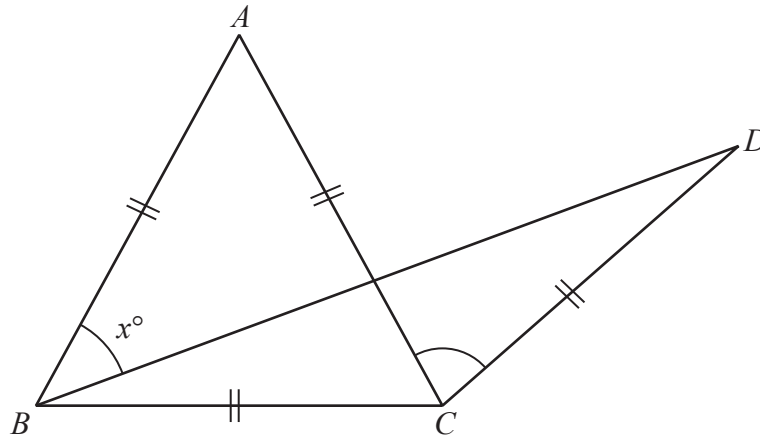

12

Diagram NOT
accurately drawn

The diagram shows an equilateral triangle ABC and an isosceles triangle BCD .

$AB = AC = BC = CD$.

Angle $ABD = x^\circ$

Express the size of angle ACD in terms of x° , giving your answer as simply as possible.

Give a reason for each step in your working.

(Total for Question 12 is 4 marks)

13 Factorise fully $4(x - 5)^2 + 3(x - 5)$

(Total for Question 13 is 2 marks)



15 A farmer has 120 metres of fencing.

He is going to make a rectangular enclosure $PQRS$ with the fencing.

He is also going to divide the enclosure into two equal parts by fencing along MN .

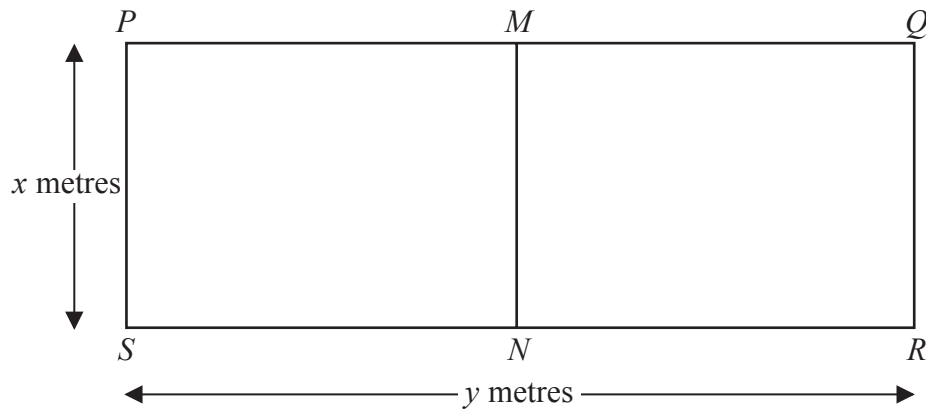

The width of the enclosure is x metres.

The length of the enclosure is y metres.

(a) (i) Show that $y = 60 - 1.5x$

The area of the enclosure $PQRS$ is A m²

(ii) Show that $A = 60x - 1.5x^2$

(3)

(b) Find $\frac{dA}{dx}$

(2)

(c) Find the maximum value of A .

$A = \dots\dots\dots$

(3)

(Total for Question 15 is 8 marks)



16 The histogram shows information about the times, t minutes, customers spent in a post office.

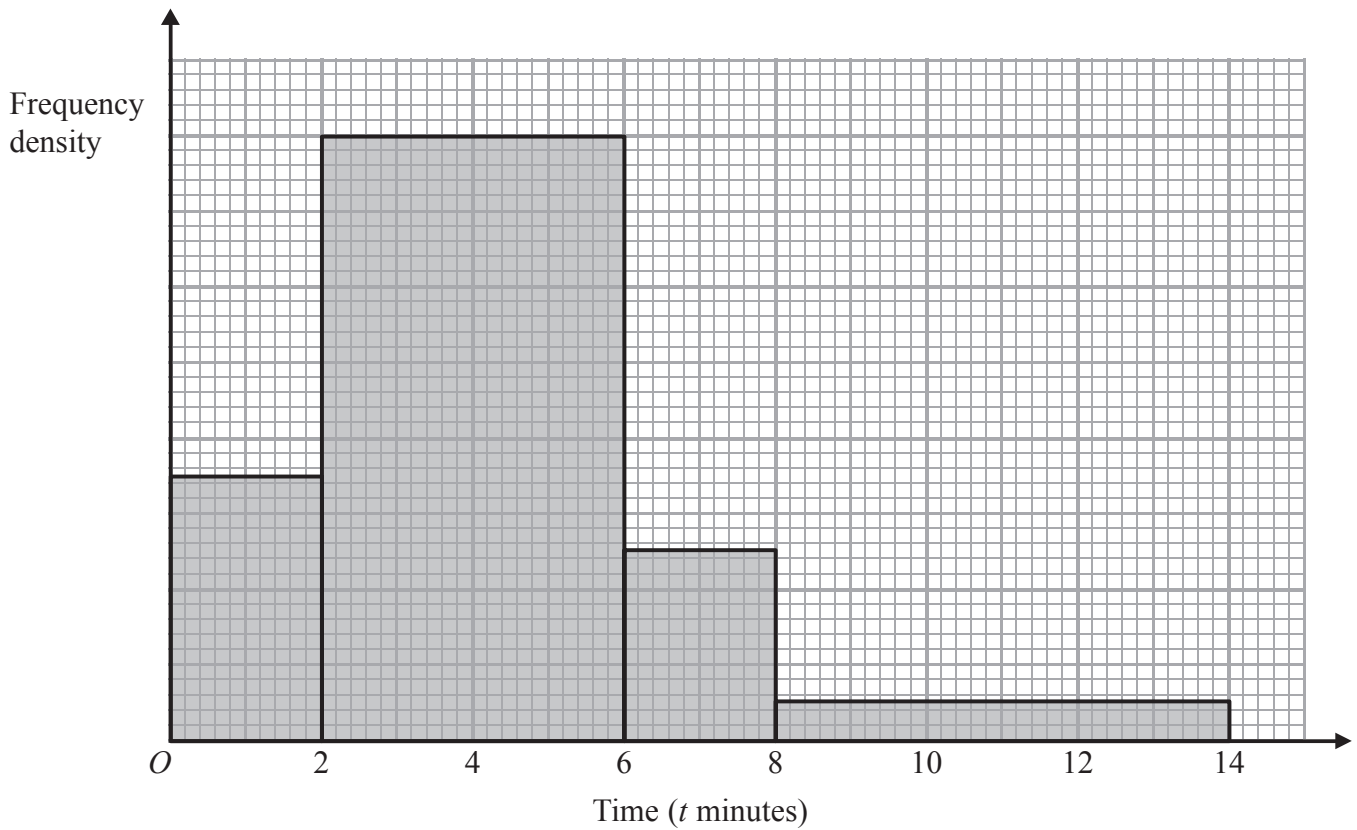

28 customers spent 2 minutes or less in the post office.

Calculate an estimate for the number of customers who spent between 5 and 14 minutes in the post office.

(Total for Question 16 is 3 marks)

Do NOT write in this space.



- 17 A circular clock face, centre O , has a minute hand OA and an hour hand OB .
 $OA = 10$ cm.
 $OB = 7$ cm.

Calculate the length of AB when the hands show 5 o'clock.
 Give your answer correct to 3 significant figures.

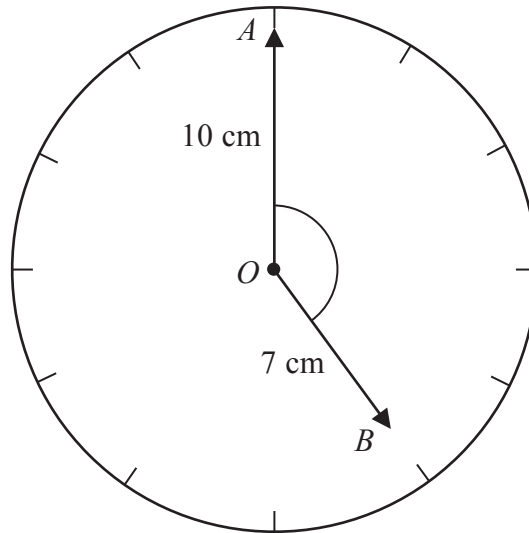

Diagram **NOT**
 accurately drawn

..... cm

(Total for Question 17 is 4 marks)



- 18 A rectangular lawn has a length of $3x$ metres and a width of $2x$ metres.
The lawn has a path of width 1 metre on three of its sides.

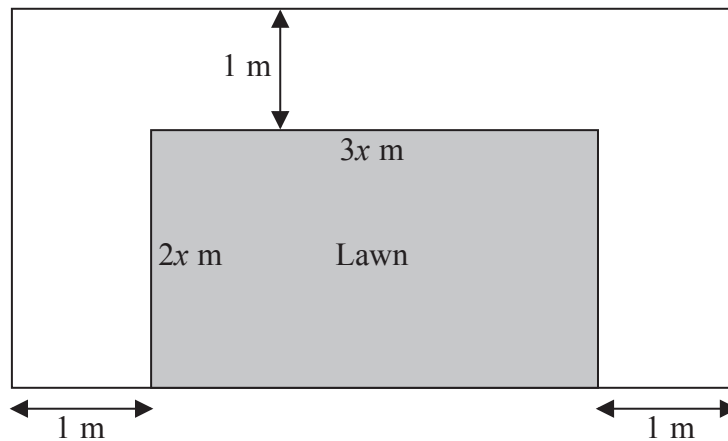

Diagram **NOT**
accurately drawn

The total area of the lawn and the path is 100 m^2

- (a) Show that $6x^2 + 7x - 98 = 0$

(2)

- (b) Calculate the area of the lawn.
Show clear algebraic working.

..... m^2

(5)

(Total for Question 18 is 7 marks)



19

Diagram **NOT**
accurately drawn

The diagram shows part of a regular polygon.
The interior angle and the exterior angle at a vertex are marked.
The size of the interior angle is 7 times the size of the exterior angle.

Work out the number of sides of the polygon.

.....
(Total for Question 19 is 3 marks)

20 Show that the recurring decimal $0.0\dot{1}\dot{5} = \frac{1}{66}$

.....
(Total for Question 20 is 2 marks)

21 There are 1300 sheets of paper, correct to the nearest 100 sheets, in a pile.
Each sheet is of equal thickness.
The height of the pile is 160 mm, correct to the nearest 10 mm.
Calculate the upper bound, in millimetres, for the thickness of one sheet of paper.

..... mm

.....
(Total for Question 21 is 3 marks)



22 Solve the simultaneous equations

$$2x - y = 7$$

$$x^2 + y^2 = 34$$

Show clear algebraic working.

.....
(Total for Question 22 is 7 marks)



- 23 A pyramid has a horizontal square base $ABCD$ with sides of length 230 metres.
 M is the midpoint of AC .
 The vertex, T , is vertically above M .
 The slant edges of the pyramid are of length 218 metres.



Calculate the height, MT , of the pyramid.
 Give your answer correct to 3 significant figures.

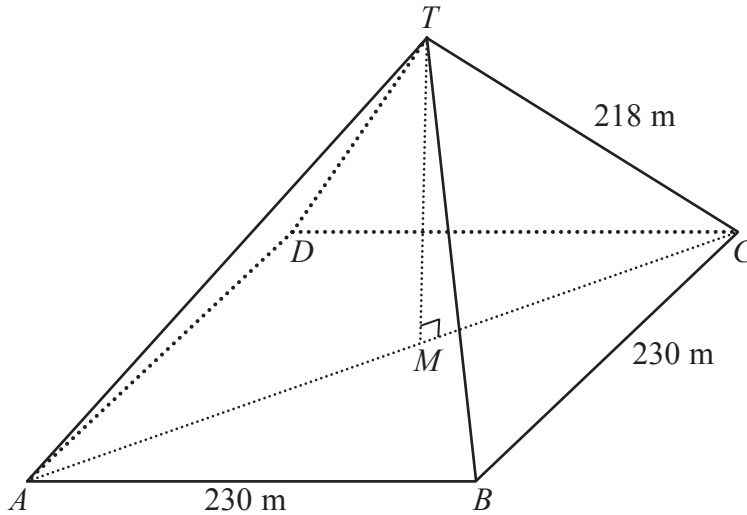

Diagram NOT
 accurately drawn

..... m

(Total for Question 23 is 5 marks)

TOTAL FOR PAPER IS 100 MARKS



BLANK PAGE

Do NOT write on this page.

