

Write your name here

Surname

Other names

Centre Number

Candidate Number

**Pearson Edexcel International
Primary Curriculum**

Science

Year 6 Achievement Test

Wednesday 3 June 2015 – Morning
Time: 1 hour

Paper Reference

JSC01/01

You do not need any other materials.

Total Marks

Instructions

- Use **black** ink or ball-point pen.
- **Fill in the boxes** at the top of this page with your name, centre number and candidate number.
- Answer **all** questions.
- Answer the questions in the spaces provided
– *there may be more space than you need.*

Information

- The total mark for this paper is 60.
- The marks for **each** question are shown in brackets
– *use this as a guide as to how much time to spend on each question.*
- Candidates may use a calculator.

Advice

- Read each question carefully before you start to answer it.
- Try to answer every question.
- Check your answers if you have time at the end.

Turn over ►

P44960A

©2015 Pearson Education Ltd.

1/1/1/1/1/1/1/

PEARSON



SECTION A

Answer ALL questions.

For questions 1 – 8 put a cross in one box ☒ to indicate your answer.

If you change your mind, put a line through the box ☒ and then put a cross in another box ☒.
Each question is worth one mark.

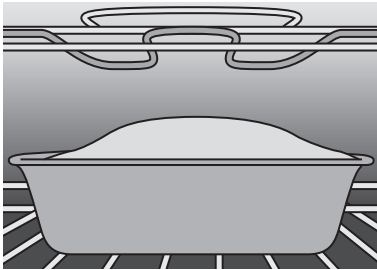
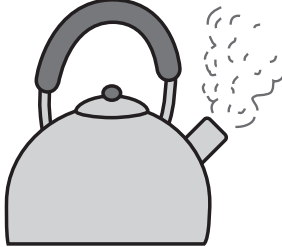
1 Which of these is a reversible change?

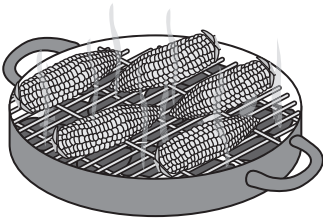
| | |
|---|---|
| <input type="checkbox"/> A baking bread |  |
| <input type="checkbox"/> B boiling water |  |
| <input type="checkbox"/> C frying chips |  |
| <input type="checkbox"/> D grilling sweetcorn |  |

(Total for Question 1 = 1 mark)



2 Which of these substances dissolves in water?

- A flour
- B salt
- C sand
- D stones





(Total for Question 2 = 1 mark)

3 Water vapour changing to liquid water is described as

- A condensing.
- B evaporating.
- C freezing.
- D melting.

(Total for Question 3 = 1 mark)

4 Which of these birds has a beak that would be best for scooping fish out of water?

| | |
|----------------------------|---|
| <input type="checkbox"/> A |  |
| <input type="checkbox"/> B |  |
| <input type="checkbox"/> C |  |
| <input type="checkbox"/> D |  |

(Total for Question 4 = 1 mark)



5 Which of these is **not** a source of light?

- A a candle
- B a lamp
- C a planet
- D the Sun

(Total for Question 5 = 1 mark)

6 Sieving can be used to separate a mixture of

- A sand and flour.
- B sand and sugar.
- C stones and sand.
- D salt and water.

(Total for Question 6 = 1 mark)

7 What sort of soil suits earthworms best?

| | Soil particles | Air gaps |
|----------------------------|--------------------------|-----------------|
| <input type="checkbox"/> A | dry and tightly packed | very few |
| <input type="checkbox"/> B | moist and tightly packed | very few |
| <input type="checkbox"/> C | dry and loosely packed | lots |
| <input type="checkbox"/> D | moist and loosely packed | lots |

(Total for Question 7 = 1 mark)



8 What is the name of the force shown by the arrow in this picture?

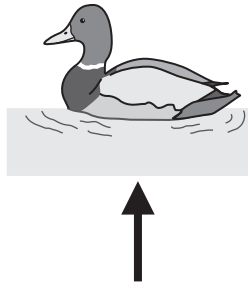

- A friction
- B gravity
- C upthrust
- D weight

(Total for Question 8 = 1 mark)

9 The animal skulls below have different types of teeth.

Draw a line from each box to match each skull with the food the animal eats.

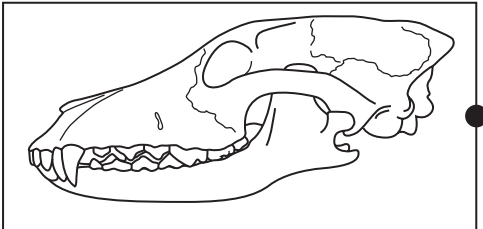

plants and meat

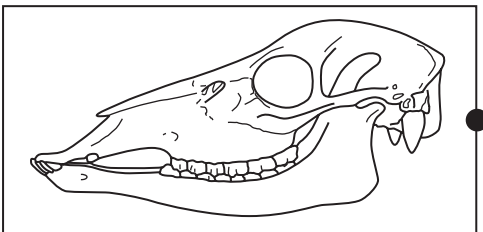

meat

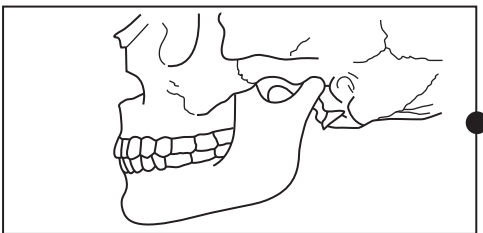

plants

(Total for Question 9 = 2 marks)



10 A gardener is burning dead leaves by the side of a road.



Give **two** hazards of burning leaves by the side of a road.

(2)

1

.....

2

.....

(Total for Question 10 = 2 marks)



11 (a) What is the unit of force?

(1)

(b) What is the reading on this forcemeter?

(1)

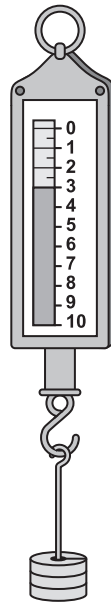

(Total for Question 11 = 2 marks)



For questions 12 – 20 put a cross in one box to indicate your answer.
If you change your mind, put a line through the box and then put a cross in another box .
Each question is worth one mark.

Use this diagram of a plant to answer questions 12 and 13.

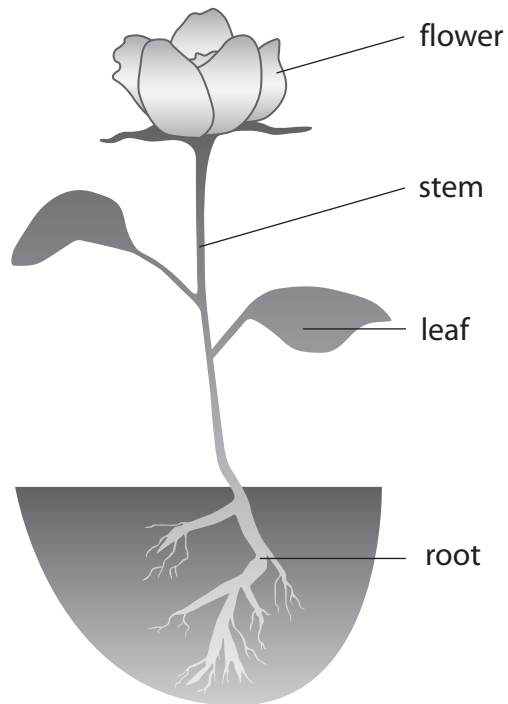

12 Which part of the plant makes most of the food for the plant?

- A** flower
- B** leaf
- C** root
- D** stem

(Total for Question 12 = 1 mark)

13 Which part of the plant takes in water?

- A** flower
- B** leaf
- C** root
- D** stem

(Total for Question 13 = 1 mark)



14 Filtration can be used to separate a mixture of

- A salt and water.
- B sand and salt.
- C sand and water.
- D sugar and salt.

(Total for Question 14 = 1 mark)

15 The arrows on the diagram show changes of state.

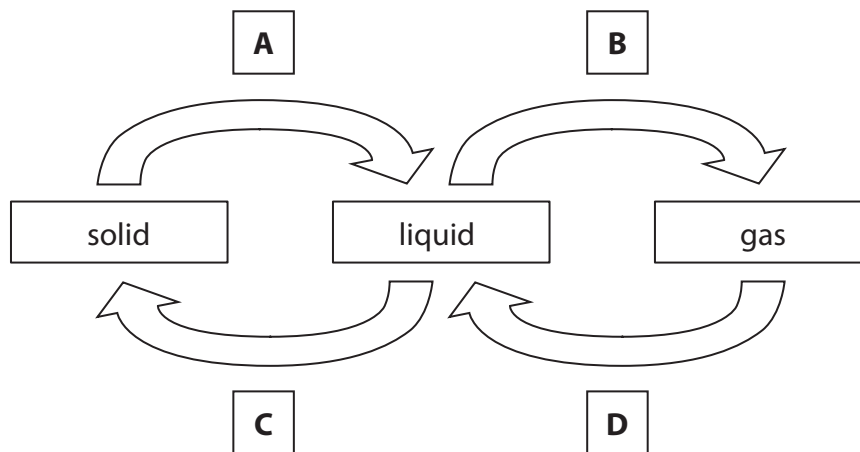

Which letter shows melting?

- A
- B
- C
- D

(Total for Question 15 = 1 mark)



16 Which row in the table correctly describes what happens when clay is heated in an oven to make pots?

| | Reversible change | Irreversible change | New materials made |
|----------------------------|-------------------|---------------------|--------------------|
| <input type="checkbox"/> A | ✓ | ✗ | ✓ |
| <input type="checkbox"/> B | ✗ | ✓ | ✗ |
| <input type="checkbox"/> C | ✓ | ✗ | ✗ |
| <input type="checkbox"/> D | ✗ | ✓ | ✓ |

(Total for Question 16 = 1 mark)

17 The pictures below show a food chain.



In this food chain, the caterpillar is a

- A carnivore.
- B consumer.
- C predator.
- D producer.

(Total for Question 17 = 1 mark)

18 Which one of the following does **not** involve micro-organisms?

- A Bread going mouldy.
- B Breakdown of dead leaves.
- C Making salad dressing.
- D Making yoghurt.

(Total for Question 18 = 1 mark)



19 What happens to the shadow when the book is moved towards the torch?

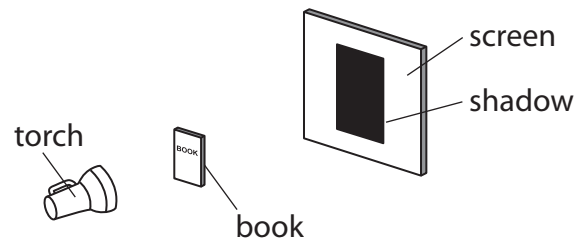

The shadow

- A gets larger.
- B gets smaller.
- C does not change size.
- D gets darker.

(Total for Question 19 = 1 mark)

20 This electric cable is made from copper and plastic.

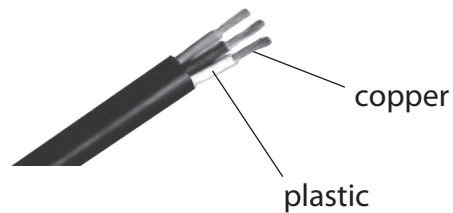

Which row in the table correctly shows the properties of copper and plastic that make them suitable for making this cable?

| | Copper | Plastic |
|----------------------------|-----------|-----------|
| <input type="checkbox"/> A | conductor | conductor |
| <input type="checkbox"/> B | conductor | insulator |
| <input type="checkbox"/> C | insulator | conductor |
| <input type="checkbox"/> D | insulator | insulator |

(Total for Question 20 = 1 mark)



21 This diagram shows a simple food web.

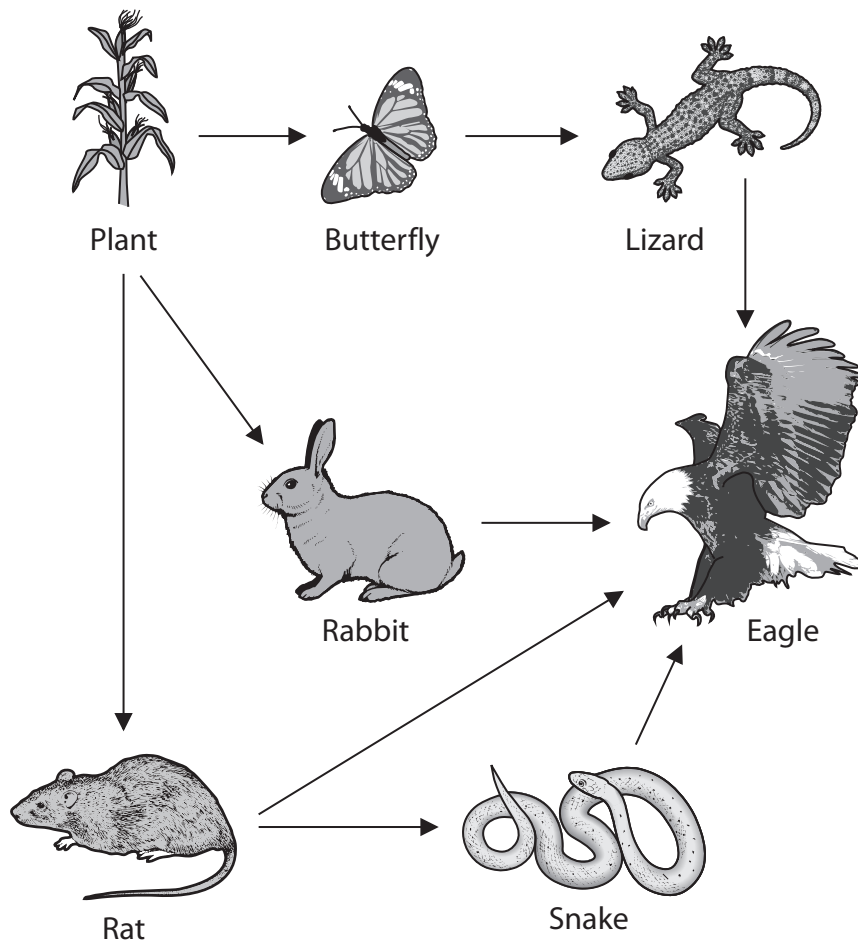

Choose words from the box to complete the sentences about this food web.

| | | |
|-----------|----------|------|
| herbivore | predator | prey |
|-----------|----------|------|

The lizard is the of the eagle. The eagle is a

(Total for Question 21 = 1 mark)

22 Some objects are described as opaque. What does the term **opaque** mean?

.....

.....

(Total for Question 22 = 1 mark)



23 (a) Give **two** ways in which this circuit could be changed to make the same bulb brighter. (2)

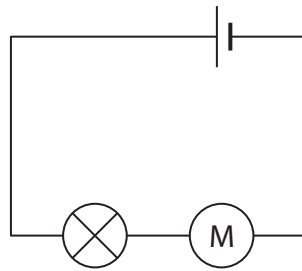

1

2

(b) In a circuit diagram, what does this symbol represent?

(1)



.....

(Total for Question 23 = 3 marks)



24 Helen has been asked to produce a key to identify these animals.



dragonfly



slug



centipede



snail

Give **two** features that Helen could use in her key to identify these animals.

1

2

(Total for Question 24 = 2 marks)



For questions 25 – 32 put a cross in one box to indicate your answer.
If you change your mind, put a line through the box and then put a cross in another box .
Each question is worth one mark.

25 In which one of these four circuits will the bulb light up?

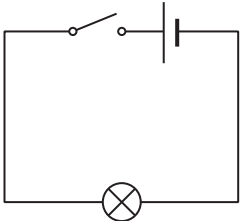
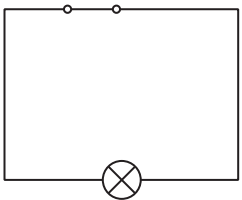
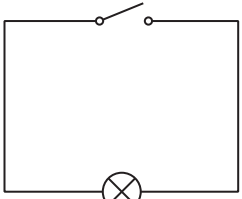
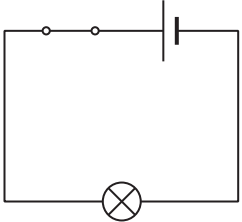
| | |
|--|---|
| <input checked="" type="checkbox"/> A |  |
| <input checked="" type="checkbox"/> B |  |
| <input checked="" type="checkbox"/> C |  |
| <input checked="" type="checkbox"/> D |  |

(Total for Question 25 = 1 mark)

26 Plants and animals have become suited to where they live. This is known as

- A** adaptation.
- B** germination.
- C** habitation.
- D** reproduction.

(Total for Question 26 = 1 mark)



27 This is a diagram of a moving object. The arrows show the forces acting on it.

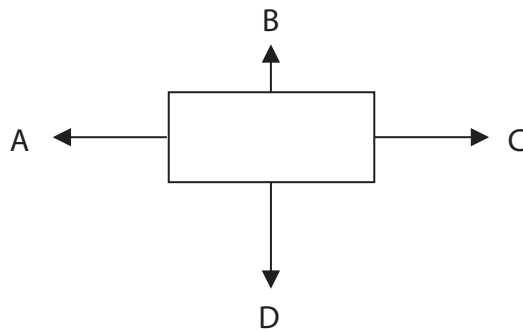

In which direction is the object moving?

- A
- B
- C
- D

(Total for Question 27 = 1 mark)

28 The substances in a mixture

- A are always the same colour.
- B are chemically joined together.
- C can be separated.
- D are always liquids.

(Total for Question 28 = 1 mark)

29 Which **one** of these statements about micro-organisms is true?

- A All micro-organisms cause disease.
- B A microscope is needed to see micro-organisms.
- C All micro-organisms are useful to humans.
- D Micro-organisms do not reproduce.

(Total for Question 29 = 1 mark)



30 The forces on this parachutist are balanced.

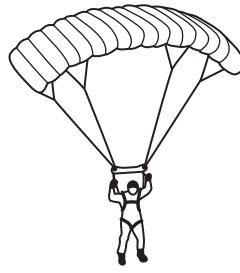

When the forces are balanced, the parachutist will

- A change direction.
- B slow down.
- C stay at the same speed.
- D go faster.

(Total for Question 30 = 1 mark)

31 This table shows how much of each solid W, X, Y and Z dissolves in 100 cm³ of water at the same temperature.

| Solid | Mass of solid that will dissolve in 100 cm ³ of water (g) |
|-------|--|
| W | 204 |
| X | 0 |
| Y | 145 |
| Z | 88 |

Which statement about Z is correct?

- A Z does not dissolve in water.
- B More of Z than Y dissolves in 100 cm³ of water.
- C Less of Z than W dissolves in 100 cm³ of water.
- D Z is less soluble than X.

(Total for Question 31 = 1 mark)



32 In which of these circuits can **both** bulbs be turned on and off **separately**?

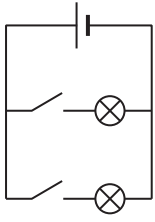

A

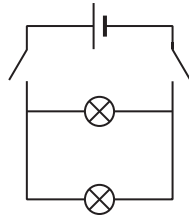

B

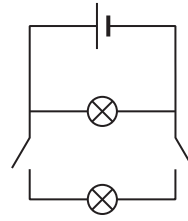

C

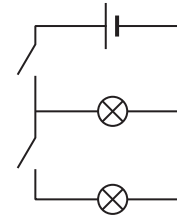

D

- A
- B
- C
- D

(Total for Question 32 = 1 mark)



33 When this candle burns, some changes take place.

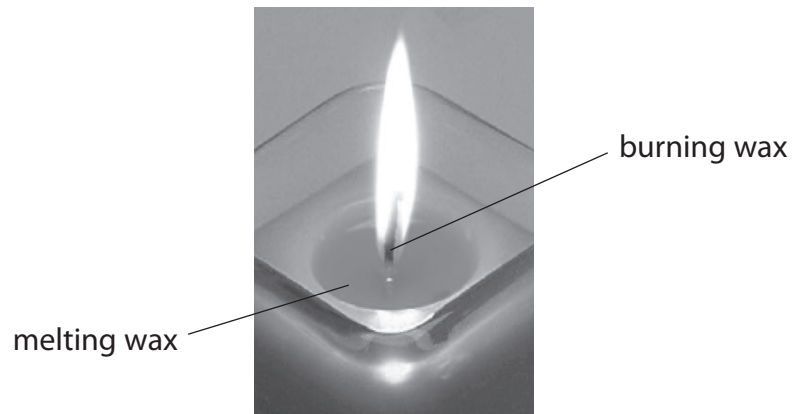

(a) What is the **reversible** change that takes place? (1)

(b) What is the **irreversible** change that takes place? (1)

(Total for Question 33 = 2 marks)



34 This is a key to identify flowering plants.

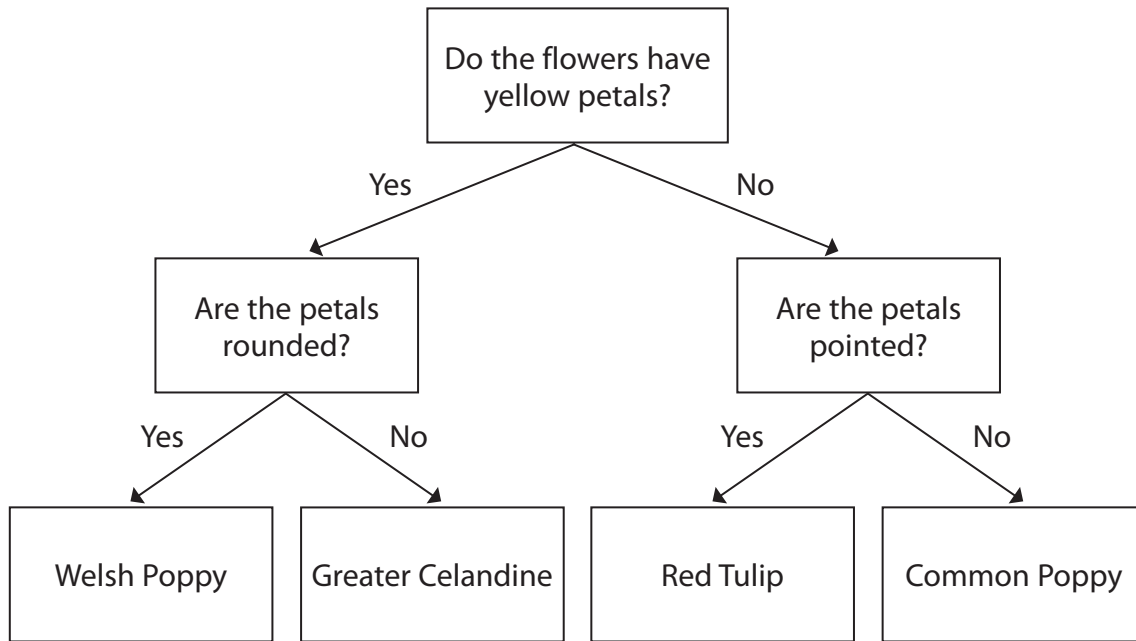

Use the key to describe the petals of a Welsh Poppy flower.

(Total for Question 34 = 2 marks)



35 Complete the diagram by putting an arrow on each ray of light to show the direction in which the light travels.

(1)

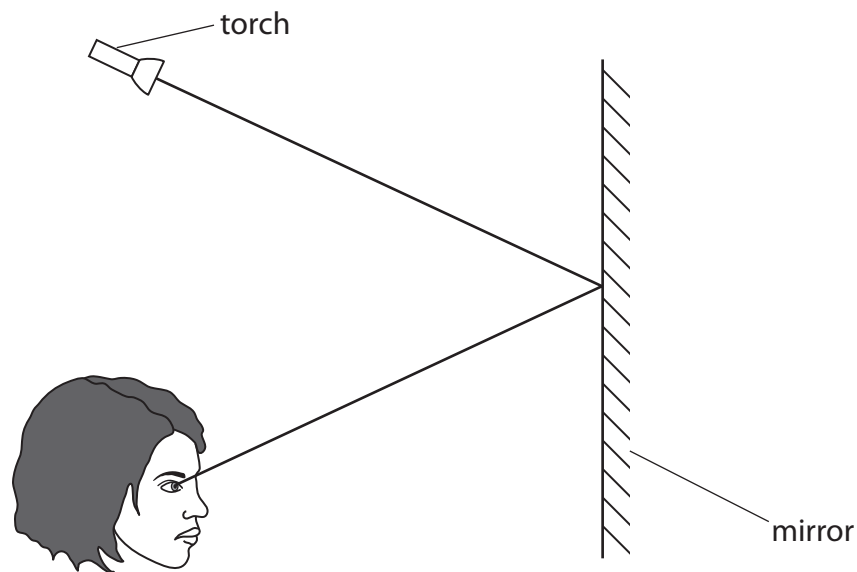

(Total for Question 35 = 1 mark)

36 (a) Salad dressing is a mixture of two liquids, vegetable oil and vinegar.

What name is given to this type of mixture?

(1)

(b) Put a circle around the box that correctly completes the sentence below.

(1)

Shaving foam is a mixture of

a gas and a liquid.

a liquid and a liquid.

a solid and a liquid.

(Total for Question 36 = 2 marks)

TOTAL FOR SECTION A = 45 MARKS



SECTION B

Answer ALL questions.

37 Molly thinks that it is harder for electricity to flow through a thin wire than a thick wire. She is planning to investigate this using a simple circuit.

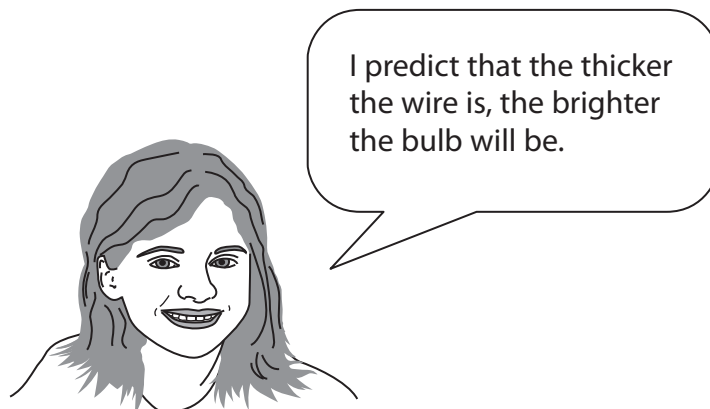

She tests four wires of different thicknesses using:

- 2 cells
- 1 bulb
- connecting wires
- switch

All the wires she tests are made of the same material.

(a) Molly draws a diagram of her circuit.

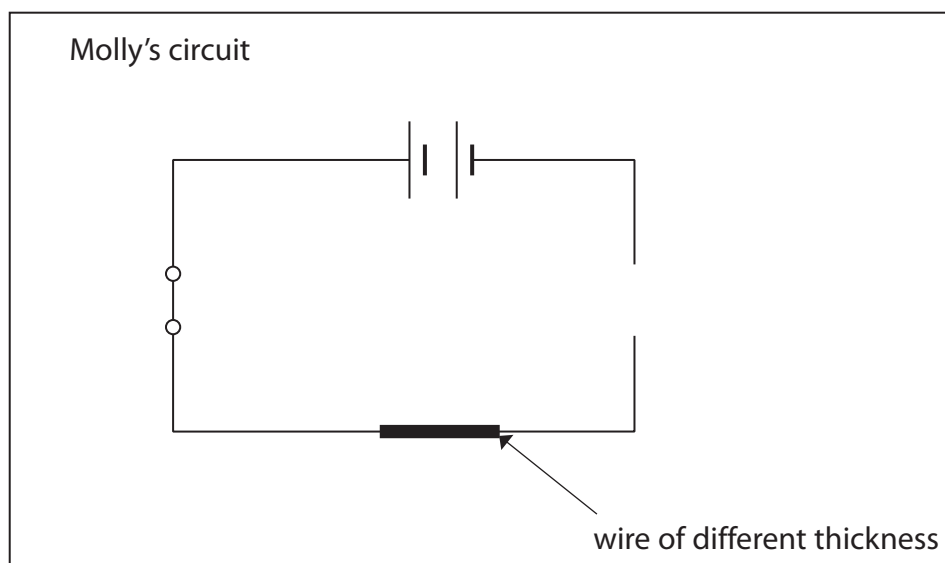

(i) Which piece of her equipment has Molly not drawn in her circuit? (1)

(ii) Why must the four wires of different thickness be the same length? (1)

(b) Molly tests each wire once. She draws this table of her results.

| Thickness of wire | Brightness of bulb |
|-------------------|--------------------|
| very thick | very bright |
| thick | quite bright |
| medium | quite bright |
| thin | not very bright |

Do these results fully agree with Molly's prediction? Explain your answer. (2)

(c) Give **two** ways that Molly could improve her investigation. (2)

1.....

2.....

(Total for Question 37 = 6 marks)



38 Ben has two colourless liquids in identical containers, shown in the picture below.

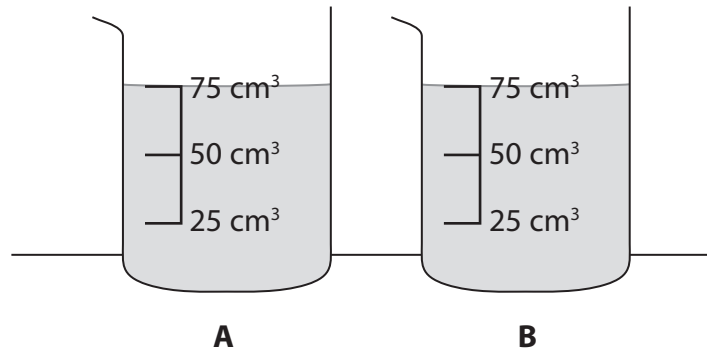

(a) Name the containers shown in the picture.

(1)

(b) What is the volume of the liquid in container A?

(1)

(c) One liquid is water, the other is sugar solution. Ben does not know which is which.

He must **not** taste them.

Describe what Ben could do to find out which liquid is the sugar solution.

(2)

(d) Ben makes some more sugar solutions to investigate how stirring affects dissolving.

Ben places 2 teaspoons of sugar into 100 cm³ of water and measures the time it takes for the sugar to dissolve.

He then repeats the investigation, but this time he stirs the mixture five times.

He does the investigation twice more, increasing the amount of stirring each time.



These are Ben's results.

15 stirs took
22 seconds to
dissolve

5 stirs took
42 seconds to
dissolve

It took
34 seconds
when I stirred it
10 times

With no stirring it
took 53 seconds
to dissolve

Draw a table to show Ben's results.

(3)



(e) Complete the bar chart of Ben's results by plotting the missing bar.

(1)

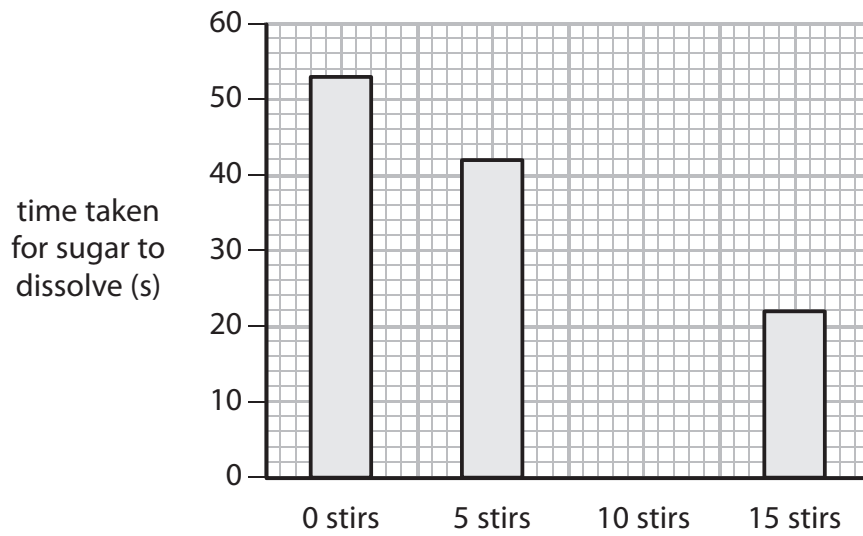

(f) Describe what Ben found out from his results.

(1)

.....

.....

(Total for Question 38 = 9 marks)

TOTAL FOR SECTION B = 15 MARKS
TOTAL FOR PAPER = 60 MARKS



BLANK PAGE



BLANK PAGE

