

Write your name here

Surname

Other names

**Pearson Edexcel
International GCSE**

Centre Number

--	--	--	--	--	--

Candidate Number

--	--	--	--	--

Mathematics A
Paper 3HR**Higher Tier**Friday 10 January 2014 – Morning
Time: 2 hoursPaper Reference
4MA0/3HR**You must have:**

Ruler graduated in centimetres and millimetres, protractor, compasses, pen, HB pencil, eraser, calculator. Tracing paper may be used.

Total Marks

Instructions

- Use **black** ink or ball-point pen.
- **Fill in the boxes** at the top of this page with your name, centre number and candidate number.
- Answer **all** questions.
- Without sufficient working, correct answers may be awarded no marks.
- Answer the questions in the spaces provided
– *there may be more space than you need.*
- **Calculators may be used.**
- You must **NOT** write anything on the formulae page.
Anything you write on the formulae page will gain NO credit.

Information

- The total mark for this paper is 100.
- The marks for **each** question are shown in brackets
– *use this as a guide as to how much time to spend on each question.*

Advice

- Read each question carefully before you start to answer it.
- Check your answers if you have time at the end.

Turn over ►

P43130A

©2014 Pearson Education Ltd.

6/6/1/1/

**PEARSON****PAPACAMBRIDGE**

**International GCSE MATHEMATICS
FORMULAE SHEET – HIGHER TIER**

Pythagoras' Theorem

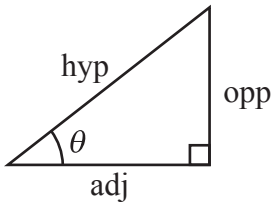
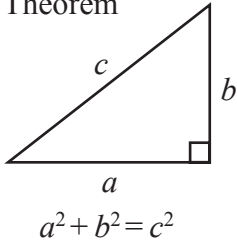

$$\begin{aligned} \text{adj} &= \text{hyp} \times \cos \theta \\ \text{opp} &= \text{hyp} \times \sin \theta \\ \text{opp} &= \text{adj} \times \tan \theta \end{aligned}$$

$$\text{or } \sin \theta = \frac{\text{opp}}{\text{hyp}}$$

$$\cos \theta = \frac{\text{adj}}{\text{hyp}}$$

$$\tan \theta = \frac{\text{opp}}{\text{adj}}$$

$$\text{Volume of cone} = \frac{1}{3} \pi r^2 h$$

$$\text{Curved surface area of cone} = \pi r l$$

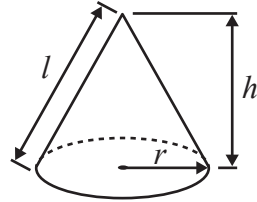

$$\text{Volume of sphere} = \frac{4}{3} \pi r^3$$

$$\text{Surface area of sphere} = 4\pi r^2$$

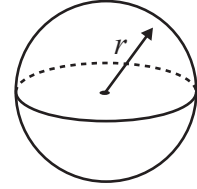

In any triangle ABC

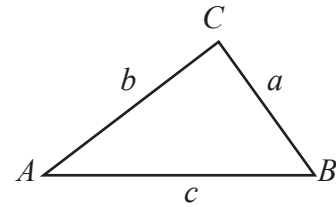

$$\text{Sine rule: } \frac{a}{\sin A} = \frac{b}{\sin B} = \frac{c}{\sin C}$$

$$\text{Cosine rule: } a^2 = b^2 + c^2 - 2bc \cos A$$

$$\text{Area of triangle} = \frac{1}{2} ab \sin C$$

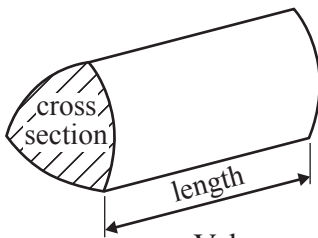

$$\text{Volume of prism} = \text{area of cross section} \times \text{length}$$

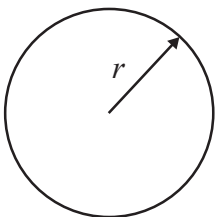

$$\text{Circumference of circle} = 2\pi r$$

$$\text{Area of circle} = \pi r^2$$

$$\text{Area of a trapezium} = \frac{1}{2}(a + b)h$$

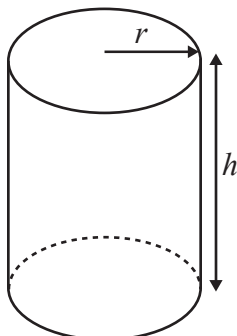
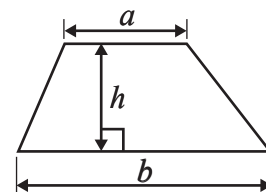

$$\text{Volume of cylinder} = \pi r^2 h$$

$$\text{Curved surface area of cylinder} = 2\pi r h$$

The Quadratic Equation

The solutions of $ax^2 + bx + c = 0$, where $a \neq 0$, are given by

$$x = \frac{-b \pm \sqrt{b^2 - 4ac}}{2a}$$



Answer ALL TWENTY TWO questions.

Write your answers in the spaces provided.

You must write down all stages in your working.

- 1** The table shows information about the number of goals scored in each of the 25 matches in a hockey tournament.

Number of goals	Number of matches
1	6
2	8
3	7
4	3
5	1

Work out the mean number of goals.

.....
(Total for Question 1 is 3 marks)

- 2** The ratio of Mark's age to Reeta's age is 3 : 5
Mark's age is 24 years.

(a) Work out Reeta's age.

..... years

(2)

The ratio of John's age to Zahra's age is 1 : 4
The sum of their ages is 45 years.

(b) Work out Zahra's age.

..... years

(2)

(Total for Question 2 is 4 marks)



3

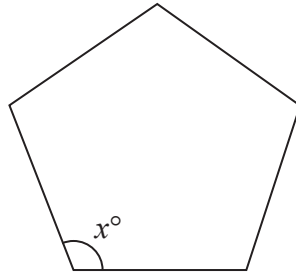

Diagram **NOT**
accurately drawn

The diagram shows a regular 5-sided polygon.

(a) Work out the value of x .

$$x = \dots\dots\dots$$

(2)

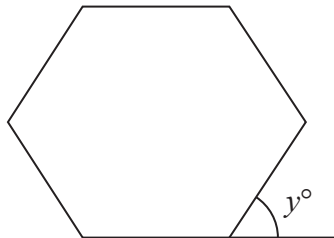

Diagram **NOT**
accurately drawn

The diagram shows a regular 6-sided polygon.

(b) Work out the value of y .

$$y = \dots\dots\dots$$

(2)

(Total for Question 3 is 4 marks)



4 (a) Factorise $t^2 + 6t$

.....
(2)

(b) Solve $7x - 5 = 5x - 4$
Show clear algebraic working.

$x =$
(3)

(c) Expand and simplify fully $4(2y + 3) + 2(y - 6)$

.....
(2)

(Total for Question 4 is 7 marks)

5 $\mathcal{E} = \{\text{even numbers}\}$

$A = \{\text{factors of 8}\}$

$B = \{\text{factors of 20}\}$

List the members of $A \cap B$

.....
(Total for Question 5 is 2 marks)

Do NOT write in this space.



- 6 (a) Dilip buys a painting for \$ 675
Later, he sells it and makes a percentage profit of 12%.

Work out the price for which Dilip sells the painting.

\$
(3)

- (b) Renuka sells her car.
She makes a loss of \$ 2162
Her percentage loss is 23%.

Work out the price for which Renuka sells her car.

\$
(3)

- (c) Lin bought a computer that had a value of \$ 1500
At the end of each year, the value of her computer had depreciated by 40% of its
value at the start of that year.

Calculate the value of her computer at the end of 3 years.

\$
(3)

(Total for Question 6 is 9 marks)

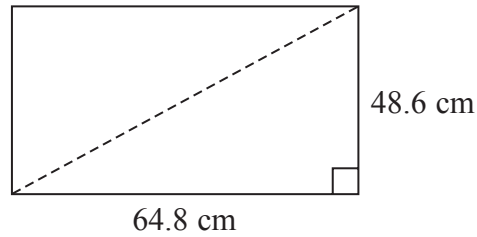

7

Diagram **NOT**
accurately drawn

A TV screen is rectangular.

The width of the rectangle is 64.8 cm and the height is 48.6 cm.

The length of a diagonal of the rectangle gives the 'size' of the TV screen.

(a) Calculate the 'size' of the TV screen.

..... cm

(3)

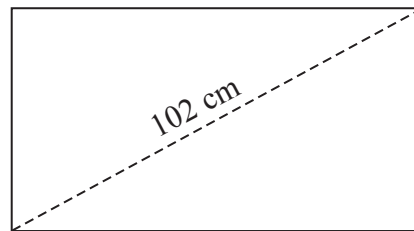
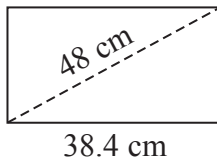
Diagram **NOT**
accurately drawn

The diagram shows two rectangular TV screens.

The rectangles are similar.

The 'size' of the smaller screen is 48 cm.

The width of the smaller screen is 38.4 cm.

The 'size' of the larger screen is 102 cm.

(b) Calculate the width of the larger TV screen.

..... cm

(2)

(Total for Question 7 is 5 marks)



- 8 Morse Code uses dots (●) and dashes (—) to represent each letter of the alphabet.
Here are 10 cards.
Each card has the Morse Code for a letter on it.

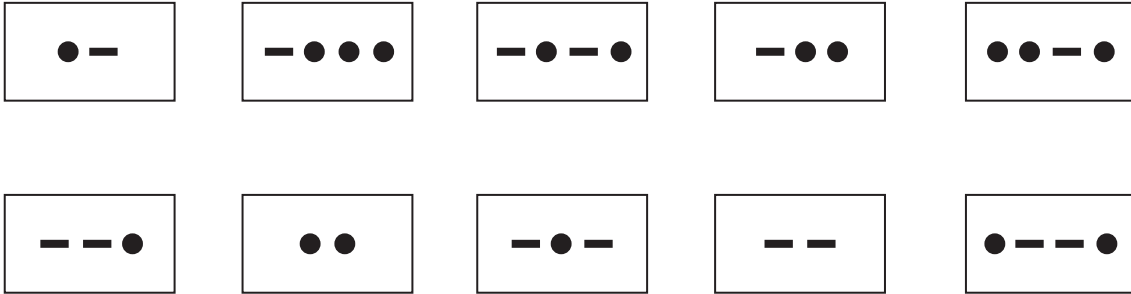

- (a) Kelly takes at random one of the cards.

Find the probability that she takes a card with 2 dots or a card with 3 dots.

.....
(2)

- (b) Hashim has the 10 cards.
He takes at random a card 200 times.
He replaces the card each time.

Work out an estimate for the number of times he will take a card with exactly 2 dots.

.....
(2)

- (c) Shani takes at random two of the 10 cards without replacement.

Calculate the probability that

- (i) there is exactly 1 dot on each card she takes,

.....

(ii) there is a total of 4 dots on the two cards she takes.

.....
(5)

(Total for Question 8 is 9 marks)

9 (a) Simplify $\frac{y^8}{y^3}$

.....
(1)

(b) Solve the inequality $4(x + 3) > 8$

.....
(2)

(Total for Question 9 is 3 marks)



- 10 The grouped frequency table gives information about the lengths of time 160 students exercised one day.

Time (t minutes)	Frequency
$0 < t \leq 40$	20
$40 < t \leq 80$	35
$80 < t \leq 120$	60
$120 < t \leq 160$	33
$160 < t \leq 200$	7
$200 < t \leq 240$	5

- (a) Complete the cumulative frequency table.

Time (t minutes)	Cumulative frequency
$0 < t \leq 40$	
$0 < t \leq 80$	
$0 < t \leq 120$	
$0 < t \leq 160$	
$0 < t \leq 200$	
$0 < t \leq 240$	

(1)

(b) On the grid, draw a cumulative frequency graph for your table.

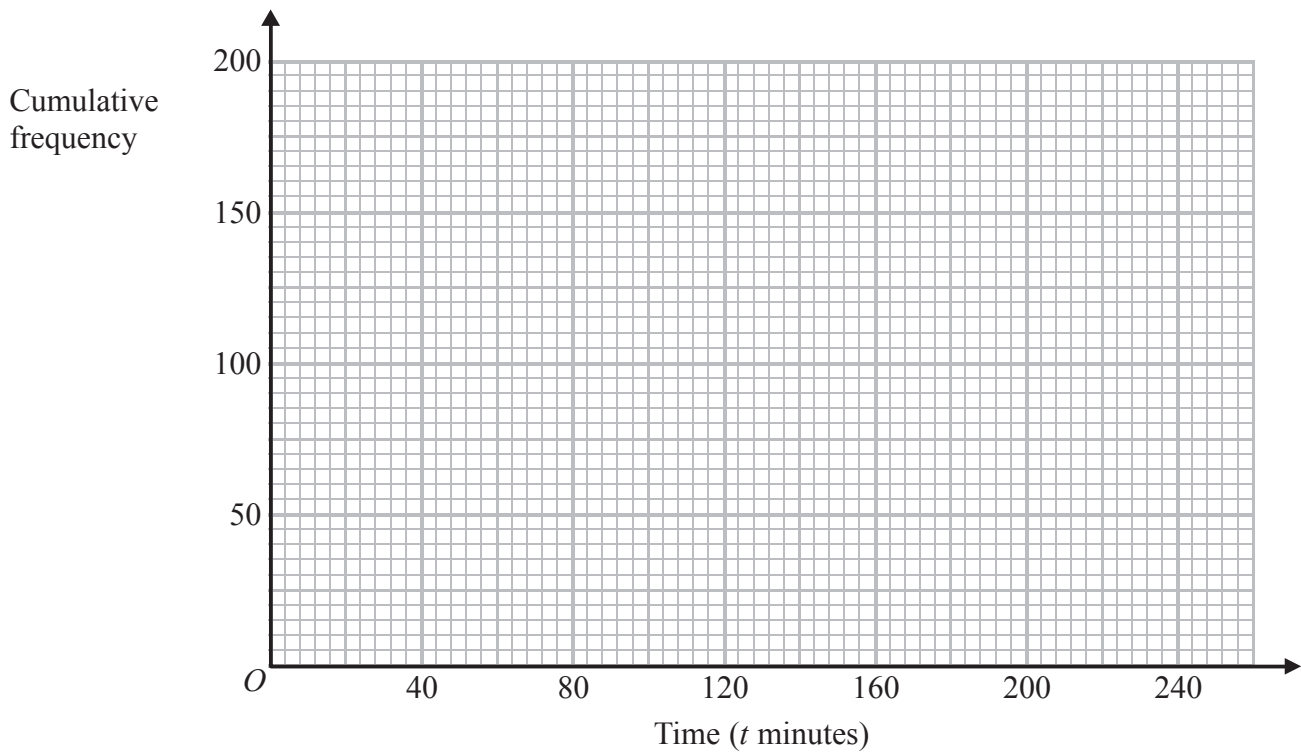

(2)

(c) Use your graph to find an estimate for the lower quartile of the lengths of time the 160 students exercised.

..... minutes

(2)

(Total for Question 10 is 5 marks)

11 Find the Lowest Common Multiple (LCM) of 20 and 24

.....
(Total for Question 11 is 2 marks)



12

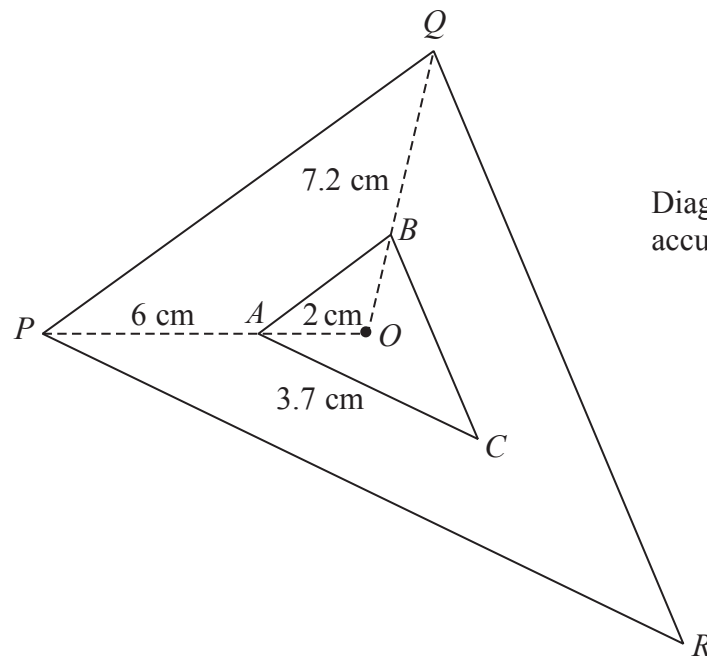

Diagram **NOT**
accurately drawn

Triangle PQR is an enlargement, centre O , of triangle ABC .

OAP and OBQ are straight lines.

$OA = 2$ cm.

$AP = 6$ cm.

$BQ = 7.2$ cm.

$AC = 3.7$ cm.

(a) Work out the length of OB .

..... cm
(2)

(b) Work out the length of PR .

..... cm
(3)

The area of triangle PQR is 72 cm^2

(c) Work out the area of triangle ABC .

..... cm^2
(2)

(Total for Question 12 is 7 marks)

13 (a) Solve the simultaneous equations $3x + 5y = 14$
 $4x + 3y = 4$

Show clear algebraic working.

$x = \dots\dots\dots$

$y = \dots\dots\dots$
(4)

(b) Write down the coordinates of the point of intersection of the two lines whose equations are $3x + 5y = 14$ and $4x + 3y = 4$

(.....,)
(1)

(Total for Question 13 is 5 marks)

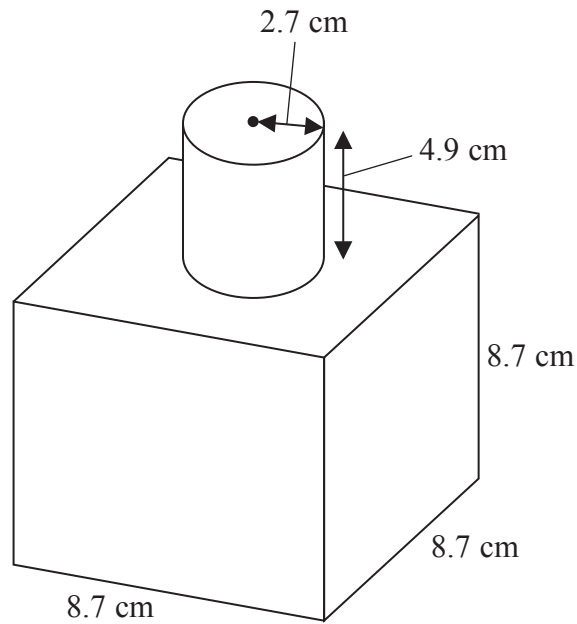

14

Diagram NOT
accurately drawn

The diagram shows a shape made from a solid cube and a solid cylinder.
The cube has sides of length 8.7 cm.
The cylinder has a radius of 2.7 cm and a height of 4.9 cm.

Calculate the total surface area of the solid shape.
Give your answer correct to 3 significant figures.

..... cm²

(Total for Question 14 is 3 marks)

15 A particle moves along a straight line.

The fixed point O lies on this line.

The displacement of the particle from O at time t seconds is s metres, where

$$s = t^3 - 6t + 3$$

(a) Find an expression for the velocity, v m/s, of the particle at time t seconds.

$$v = \dots\dots\dots$$

(2)

(b) Find the acceleration of the particle at time 5 seconds.

$$\dots\dots\dots \text{ m/s}^2$$

(2)

(Total for Question 15 is 4 marks)

16 Make r the subject of the formula $A = 4r^2 - \pi r^2$ where r is positive.

$$r = \dots\dots\dots$$

(Total for Question 16 is 3 marks)

Do NOT write in this space.



17

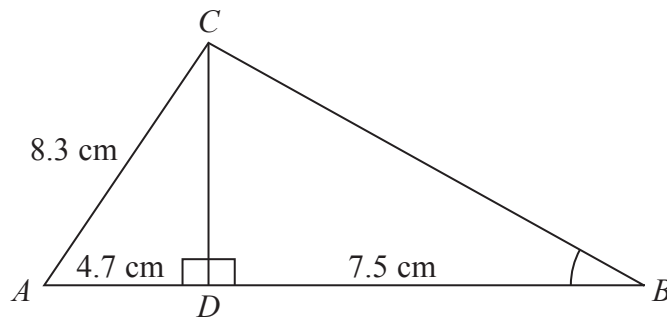

Diagram NOT
accurately drawn

The diagram shows triangle ABC .

D is the point on AB , such that CD is perpendicular to AB .

$AC = 8.3$ cm.

$AD = 4.7$ cm.

$BD = 7.5$ cm.

Calculate the size of angle ABC .

Give your answer correct to 1 decimal place.

(Total for Question 17 is 4 marks)



18

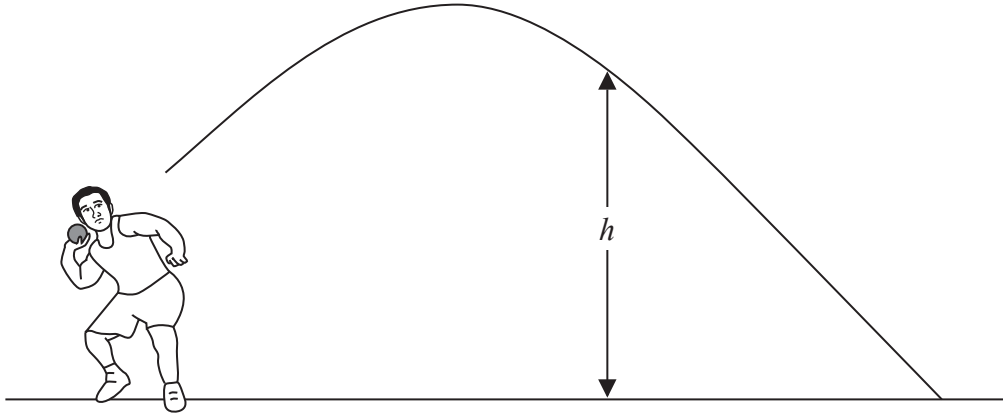

Ivan is a shot putter.

The formula $h = 2 + 6t - 5t^2$ gives the height, h metres, of the shot above the ground t seconds after he has released the shot.

- (i) Solve $2 + 6t - 5t^2 = 0$
 Give your solutions correct to 3 significant figures.
 Show your working clearly.

The shot hits the ground after T seconds.

- (ii) Write down the value of T .
 Give your answer correct to 3 significant figures.

$T = \dots\dots\dots$

(Total for Question 18 is 4 marks)



- 19 Given that x and y are positive integers such that $(1 + \sqrt{x})(3 + \sqrt{x}) = y + 4\sqrt{5}$
find the value of x and the value of y .

$x = \dots\dots\dots$

$y = \dots\dots\dots$

(Total for Question 19 is 3 marks)

- 20 Simplify fully $\frac{x^2 - 16}{x^2 - 6x + 8}$

(Total for Question 20 is 3 marks)



21

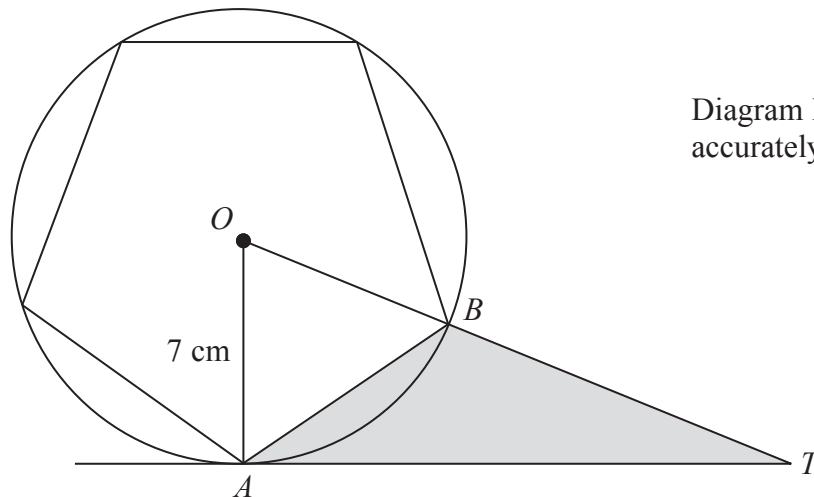

Diagram **NOT**
accurately drawn

The diagram shows a regular pentagon inside a circle, centre O .
The points A and B lie on the circle such that AB is a side of the pentagon.
 $OA = 7$ cm.
 TA is a tangent to the circle and OBT is a straight line.

Calculate the area of triangle ABT .
Give your answer correct to 3 significant figures.

..... cm²

(Total for Question 21 is 5 marks)



P 4

PAPACAMBRIDGE



2 0

22 The functions f and g are such that $f(x) = x + 3$ and $g(x) = \frac{1}{x - 2}$

(a) Find $fg(x)$

Give your answer as a single algebraic fraction expressed as simply as possible.

.....
(3)

(b) Express the inverse function g^{-1} in the form $g^{-1}(x) = \dots$

$g^{-1}(x) = \dots$
(3)

(Total for Question 22 is 6 marks)

TOTAL FOR PAPER IS 100 MARKS

Do NOT write in this space.