

Write your name here

Surname

Other names

Edexcel Certificate

Centre Number

Candidate Number

**Edexcel
International GCSE**

--	--	--	--	--

--	--	--	--

Mathematics A

Paper 3H**Higher Tier**

Friday 10 May 2013 – Afternoon

Time: 2 hours

Paper Reference

**4MA0/3H
KMA0/3H****You must have:**

Ruler graduated in centimetres and millimetres, protractor, compasses, pen, HB pencil, eraser, calculator. Tracing paper may be used.

Total Marks

Instructions

- Use **black** ink or ball-point pen.
- **Fill in the boxes** at the top of this page with your name, centre number and candidate number.
- Answer **all** questions.
- Without sufficient working, correct answers may be awarded no marks.
- Answer the questions in the spaces provided
– *there may be more space than you need.*
- **Calculators may be used.**
- You must **NOT** write anything on the formulae page.
Anything you write on the formulae page will gain NO credit.

Information

- The total mark for this paper is 100.
- The marks for **each** question are shown in brackets
– *use this as a guide as to how much time to spend on each question.*

Advice

- Read each question carefully before you start to answer it.
- Check your answers if you have time at the end.

Turn over ►

P42070A

©2013 Pearson Education Ltd.

6/5/5/



P 4 2 0 7 0 A 0 1 2 0

PEARSON**PAPACAMBRIDGE**

**International GCSE MATHEMATICS
FORMULAE SHEET – HIGHER TIER**

Pythagoras' Theorem

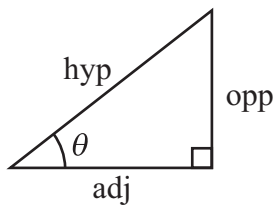
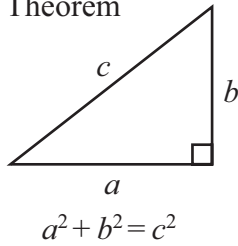

$$\text{Volume of cone} = \frac{1}{3} \pi r^2 h$$

$$\text{Curved surface area of cone} = \pi r l$$

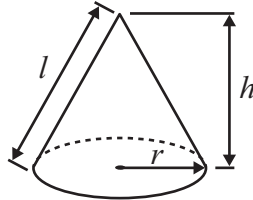

$$\text{Volume of sphere} = \frac{4}{3} \pi r^3$$

$$\text{Surface area of sphere} = 4\pi r^2$$

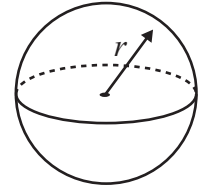

$$\begin{aligned} \text{adj} &= \text{hyp} \times \cos \theta \\ \text{opp} &= \text{hyp} \times \sin \theta \\ \text{opp} &= \text{adj} \times \tan \theta \end{aligned}$$

$$\text{or } \sin \theta = \frac{\text{opp}}{\text{hyp}}$$

$$\cos \theta = \frac{\text{adj}}{\text{hyp}}$$

$$\tan \theta = \frac{\text{opp}}{\text{adj}}$$

In any triangle ABC

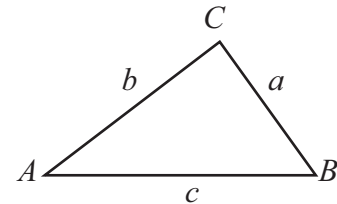

$$\text{Sine rule: } \frac{a}{\sin A} = \frac{b}{\sin B} = \frac{c}{\sin C}$$

$$\text{Cosine rule: } a^2 = b^2 + c^2 - 2bc \cos A$$

$$\text{Area of triangle} = \frac{1}{2} ab \sin C$$

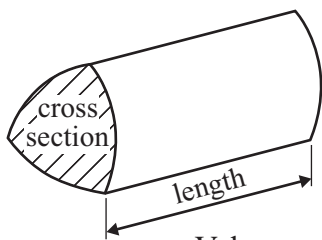

$$\text{Volume of prism} = \text{area of cross section} \times \text{length}$$

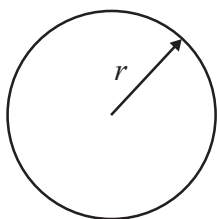

$$\text{Circumference of circle} = 2\pi r$$

$$\text{Area of circle} = \pi r^2$$

$$\text{Area of a trapezium} = \frac{1}{2}(a + b)h$$

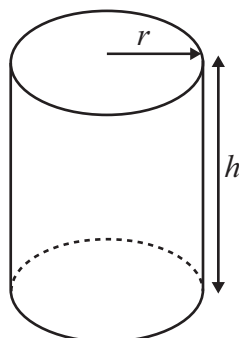
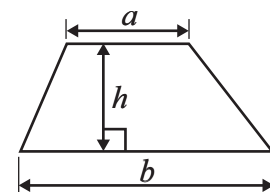

$$\text{Volume of cylinder} = \pi r^2 h$$

$$\text{Curved surface area of cylinder} = 2\pi r h$$

The Quadratic Equation

The solutions of $ax^2 + bx + c = 0$, where $a \neq 0$, are given by

$$x = \frac{-b \pm \sqrt{b^2 - 4ac}}{2a}$$



Answer ALL TWENTY TWO questions.

Write your answers in the spaces provided.

You must write down all stages in your working.

- 1** The table shows information about the mark scored on an examination question by each of 40 students.

Mark	Number of students
0	13
1	2
2	3
3	8
4	14

Work out the mean mark.

.....
(Total for Question 1 is 3 marks)



2 (a) Work out the value of $\frac{\sqrt{7.4}}{9.8 - 2.1}$

Give your answer as a decimal.

Write down all the figures on your calculator display.

.....
(2)

(b) Give your answer to part (a) correct to 2 significant figures.

.....
(1)

(Total for Question 2 is 3 marks)

3 (a) Multiply out $6(n - 2)$

.....
(1)

(b) Factorise $p^2 - 5p$

.....
(2)

(c) Solve $\frac{7x - 3}{2} = x$

Show clear algebraic working.

$x =$

(3)

(Total for Question 3 is 6 marks)



4

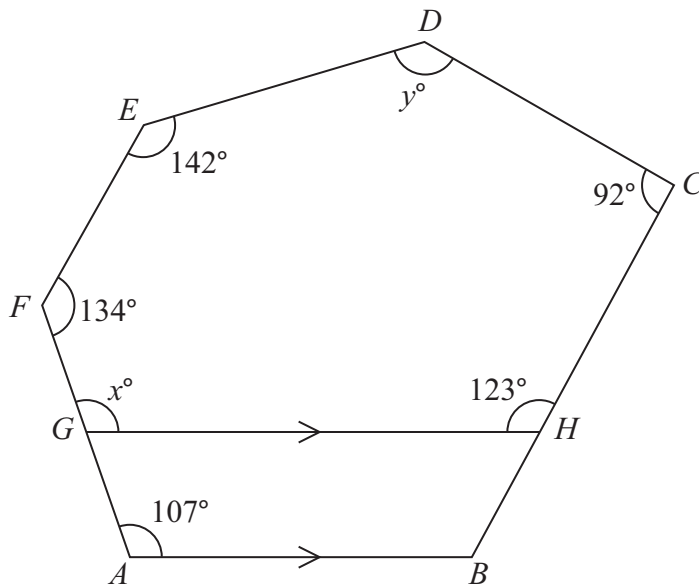

Diagram **NOT**
accurately drawn

$ABCDEF$ is a hexagon.

G is a point on AF .

H is a point on BC .

GH is parallel to AB .

(a) Give a reason why $x = 107$

(1)

(b) Work out the value of y .

$y = \dots\dots\dots$

(4)

(Total for Question 4 is 5 marks)



5

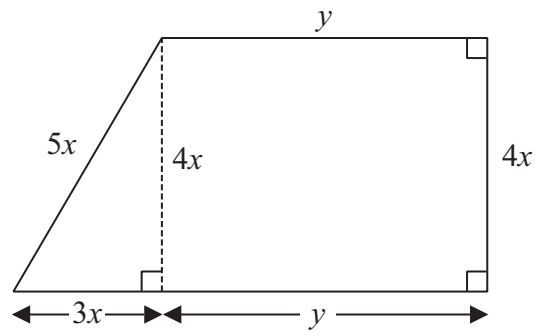

Diagram **NOT**
accurately drawn

The shape in the diagram is made from a rectangle and a right-angled triangle.
The diagram shows, in terms of x and y , the lengths, in centimetres, of the sides of the rectangle and of the triangle.

The perimeter, P cm, of the shape is given by the formula

$$P = 12x + 2y$$

(a) Work out the value of x when $P = 43$ and $y = 6.5$

$$x = \dots\dots\dots$$

(3)

(b) Find, in terms of x and y , a formula for the area, A cm², of the shape.
Give your answer as simply as possible.

$$A = \dots\dots\dots$$

(2)

(Total for Question 5 is 5 marks)

6

6 An airline increases the prices of its flights by 8%.

(a) Before the increase, the price of a flight to Cairo was £475

Work out the price of a flight to Cairo after the increase.

£.....

(3)

(b) The increase in price of a flight to Mumbai was £48

Work out the price of a flight to Mumbai after the increase.

£.....

(3)

(Total for Question 6 is 6 marks)

7 $S = \{s, q, u, a, r, e\}$

$V = \{a, e, i, o, u\}$

List the members of the set

(i) $S \cap V$

.....

(ii) $S \cup V$

.....

(Total for Question 7 is 2 marks)



8

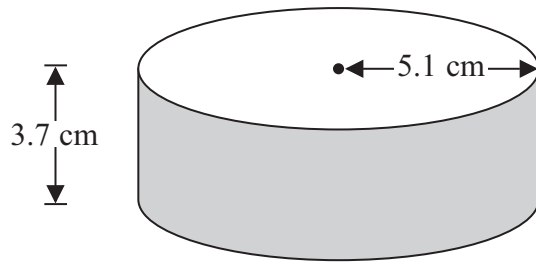

Diagram **NOT**
accurately drawn

A solid cylinder has a radius of 5.1 cm and a height of 3.7 cm.

Work out the **total** surface area of the cylinder.
Give your answer correct to 3 significant figures.

..... cm²

(Total for Question 8 is 3 marks)

9 The number of runners in the London Marathon on 25th April, 2010 was 37 527.

Work out an estimate for the number of these runners whose birthday was on that day.

.....

(Total for Question 9 is 4 marks)

10

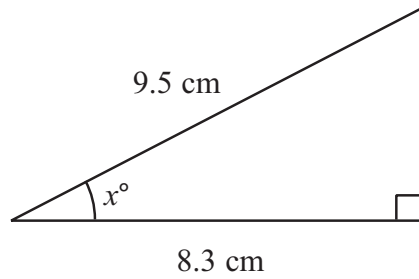
Diagram **NOT**
accurately drawn

Work out the value of x .
Give your answer correct to 1 decimal place.

 $x = \dots\dots\dots$ **(Total for Question 10 is 3 marks)**

11 (a) Find the Highest Common Factor (HCF) of 54 and 90

 $\dots\dots\dots$
(2)

(b) Find the Lowest Common Multiple (LCM) of 54 and 90

 $\dots\dots\dots$
(2)**(Total for Question 11 is 4 marks)**

12 The cumulative frequency table shows information about the diameters of 60 oranges.

Diameter (d mm)	Cumulative frequency
$50 < d \leq 60$	12
$50 < d \leq 70$	42
$50 < d \leq 80$	54
$50 < d \leq 90$	57
$50 < d \leq 100$	59
$50 < d \leq 110$	60

(a) On the grid, draw a cumulative frequency graph for the table.

(2)

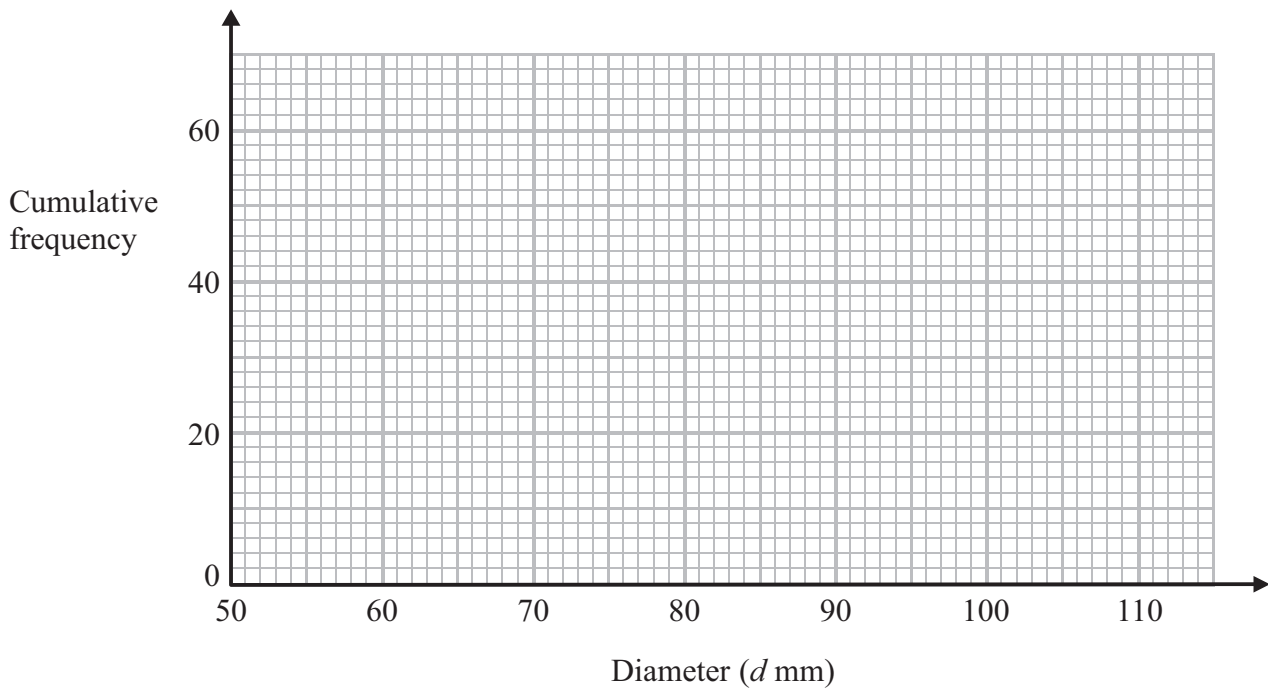

(b) Use your graph to find an estimate for the median diameter of the 60 oranges.

..... mm

(2)

(Total for Question 12 is 4 marks)



13

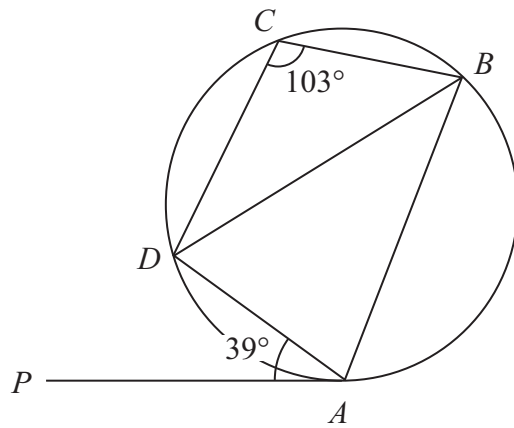

Diagram **NOT**
accurately drawn

A, B, C and D are points on a circle.

PA is a tangent to the circle.

Angle $PAD = 39^\circ$

Angle $BCD = 103^\circ$

Calculate the size of angle ADB .

(Total for Question 13 is 3 marks)

14 (a) Simplify $4p^3q^5 \times 6p^2q$

.....
(2)

(b) Simplify $(5x^2y^4)^3$

.....
(2)

(c) Factorise $9a^2 - b^2$

.....
(2)

(Total for Question 14 is 6 marks)



15

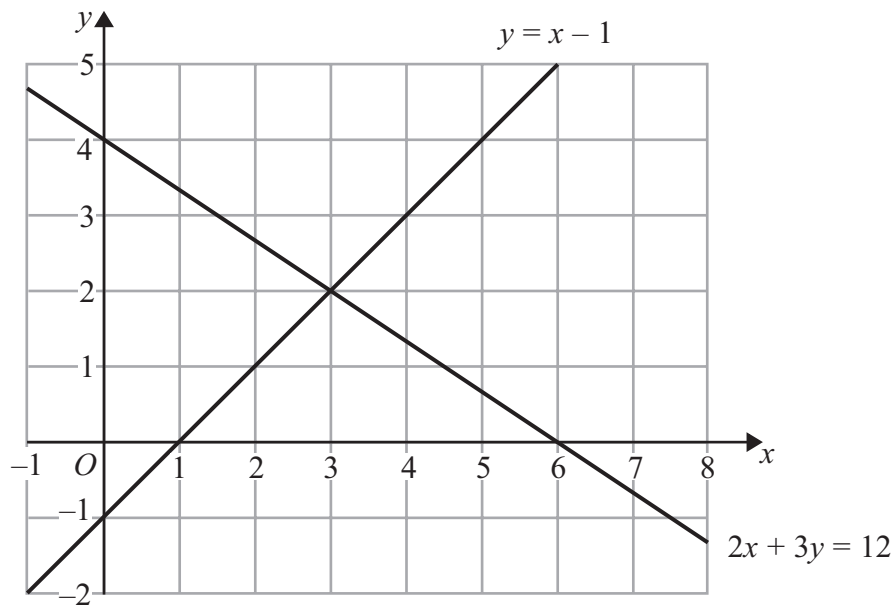

The diagram shows two straight lines.

The equations of the lines are $y = x - 1$ and $2x + 3y = 12$

(a) Write down the solution of the simultaneous equations

$$\begin{aligned} y &= x - 1 \\ 2x + 3y &= 12 \end{aligned}$$

$$x = \dots\dots\dots, y = \dots\dots\dots$$

(1)

(b) Find an equation of the line which is parallel to the line with equation $2x + 3y = 12$ and passes through the point $(0, 10)$

.....
(4)

(c) On the grid, mark with a cross (×) each point which satisfies both these inequalities $y > x - 1$ and $2x + 3y < 12$ and whose coordinates are **positive integers**.

(2)

(Total for Question 15 is 7 marks)



16

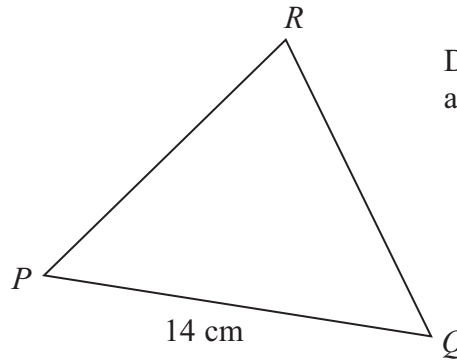
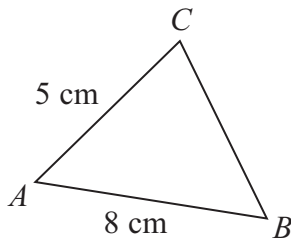

Diagram **NOT**
accurately drawn

Triangle ABC is similar to triangle PQR .

AB corresponds to PQ .

AC corresponds to PR .

$AB = 8\text{ cm}$.

$AC = 5\text{ cm}$.

$PQ = 14\text{ cm}$.

(a) Calculate the length of PR .

..... cm
(2)

The area of triangle ABC is 16 cm^2

(b) Calculate the area of triangle PQR .

..... cm^2
(3)

(Total for Question 16 is 5 marks)



17 Parveen travels to school either by bicycle or by bus.

The probability that, on any day, she will travel by bicycle is 0.7

When she travels by bicycle, the probability that she will be late for school is 0.2

When she travels by bus, the probability that she will be late for school is 0.1

(a) Calculate the probability that, on a randomly chosen day, Parveen will travel by bus and be late for school.

.....
(2)

(b) Calculate the probability that, on a randomly chosen day, Parveen will not be late for school.

.....
(3)

(Total for Question 17 is 5 marks)

Do NOT write in this space.



18

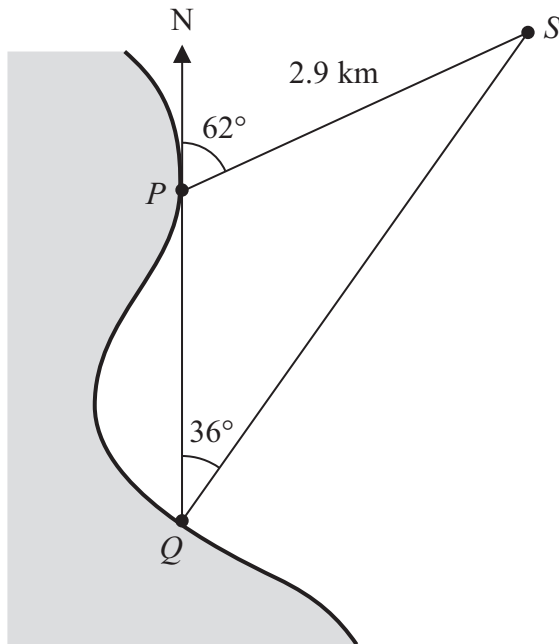

Diagram **NOT**
accurately drawn

P and Q are two points on a coast.

P is due North of Q .

A ship is at the point S .

$PS = 2.9$ km.

The bearing of the ship from P is 062°

The bearing of the ship from Q is 036°

Calculate the distance QS .

Give your answer correct to 3 significant figures.

..... km

(Total for Question 18 is 3 marks)



19 (a) Correct to the nearest millimetre, the length of a side of a regular hexagon is 3.6 cm.

Calculate the upper bound for the perimeter of the regular hexagon.

..... cm

(2)

(b) Correct to 1 significant figure, the area of a rectangle is 80 cm^2

Correct to 2 significant figures, the length of the rectangle is 12 cm.

Calculate the lower bound for the width of the rectangle.

Show your working clearly.

..... cm

(3)

(Total for Question 19 is 5 marks)

Do NOT write in this space.



20

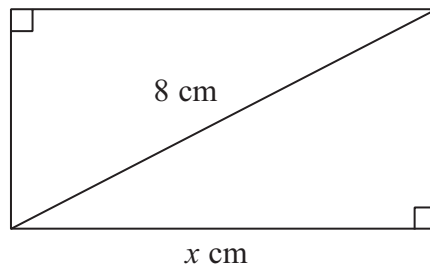

Diagram **NOT**
accurately drawn

The diagram shows a rectangle.
The length of the rectangle is x cm.
The length of a diagonal of the rectangle is 8 cm.
The perimeter of the rectangle is 20 cm.

(a) Show that $x^2 - 10x + 18 = 0$

(4)

(b) Solve $x^2 - 10x + 18 = 0$
Give your solutions correct to 3 significant figures.
Show your working clearly.

(3)

(Total for Question 20 is 7 marks)



21 Here is a shape.

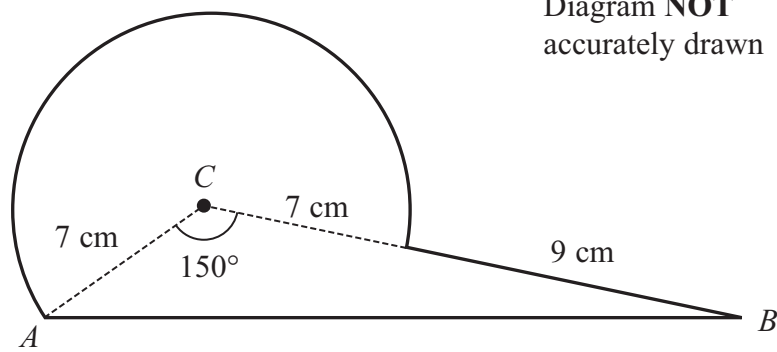

The shape is made from triangle ABC and a sector of a circle, centre C and radius CA .

$CA = 7$ cm.

$CB = 16$ cm.

Angle $ACB = 150^\circ$

Calculate the area of the shape.

Give your answer correct to 3 significant figures.

..... cm²

(Total for Question 21 is 6 marks)



22 Make y the subject of $\frac{y}{x} + \frac{2y}{x+4} = 3$

Show your working clearly and give your answer as simply as possible.

$$y = \dots\dots\dots$$

(Total for Question 22 is 5 marks)

TOTAL FOR PAPER IS 100 MARKS

Do NOT write in this space.



BLANK PAGE

Do NOT write on this page.