

Write your name here			
Surname		Other names	
Pearson Edexcel Certificate Pearson Edexcel International GCSE		Centre Number	Candidate Number
		<input type="text"/> <input type="text"/> <input type="text"/> <input type="text"/> <input type="text"/>	<input type="text"/> <input type="text"/> <input type="text"/> <input type="text"/>
<h1 style="margin: 0;">Mathematics A</h1> <h2 style="margin: 0;">Paper 3H</h2>			
Higher Tier			
Thursday 21 May 2015 – Morning Time: 2 hours		Paper Reference 4MA0/3H KMA0/3H	
You must have: Ruler graduated in centimetres and millimetres, protractor, compasses, pen, HB pencil, eraser, calculator. Tracing paper may be used.			Total Marks <input style="width: 80px; height: 40px;" type="text"/>

Instructions

- Use **black** ink or ball-point pen.
- **Fill in the boxes** at the top of this page with your name, centre number and candidate number.
- Answer **all** questions.
- Without sufficient working, correct answers may be awarded no marks.
- Answer the questions in the spaces provided
– *there may be more space than you need.*
- **Calculators may be used.**
- You must **NOT** write anything on the formulae page.
Anything you write on the formulae page will gain NO credit.

Information

- The total mark for this paper is 100.
- The marks for **each** question are shown in brackets
– *use this as a guide as to how much time to spend on each question.*

Advice

- Read each question carefully before you start to answer it.
- Check your answers if you have time at the end.

Turn over ►

P44388A

©2015 Pearson Education Ltd.

1/1/1/1/



PEARSON

**International GCSE MATHEMATICS
FORMULAE SHEET – HIGHER TIER**

Pythagoras' Theorem

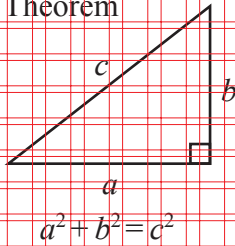

Volume of cone = $\frac{1}{3}\pi r^2 h$

Volume of sphere = $\frac{4}{3}\pi r^3$

Curved surface area of cone = $\pi r l$

Surface area of sphere = $4\pi r^2$

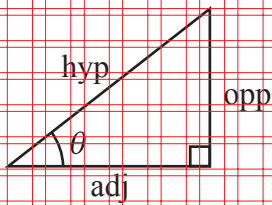
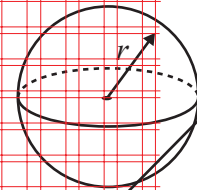
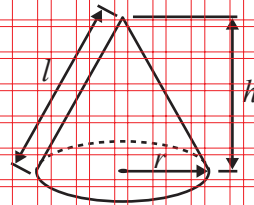

adj = hyp \times cos θ
opp = hyp \times sin θ
opp = adj \times tan θ

or $\sin \theta = \frac{\text{opp}}{\text{hyp}}$

$\cos \theta = \frac{\text{adj}}{\text{hyp}}$

$\tan \theta = \frac{\text{opp}}{\text{adj}}$

In any triangle ABC

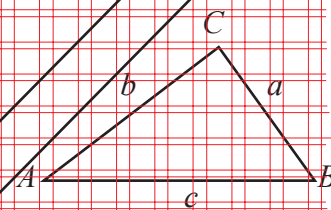

Sine rule: $\frac{a}{\sin A} = \frac{b}{\sin B} = \frac{c}{\sin C}$

Cosine rule: $a^2 = b^2 + c^2 - 2bc \cos A$

Area of triangle = $\frac{1}{2} ab \sin C$

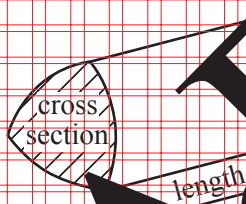

Volume of prism = area of cross section \times length

Circumference of circle = $2\pi r$

Area of circle = πr^2

Area of a trapezium = $\frac{1}{2}(a + b)h$

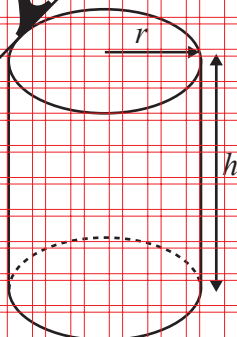
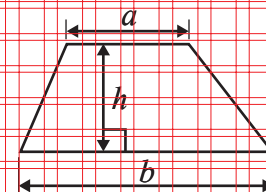

Volume of cylinder = $\pi r^2 h$

Curved surface area of cylinder = $2\pi r h$

The Quadratic Equation

The solutions of $ax^2 + bx + c = 0$, where $a \neq 0$, are given by

$x = \frac{-b \pm \sqrt{b^2 - 4ac}}{2a}$



Answer ALL TWENTY FOUR questions.

Write your answers in the spaces provided.

You must write down all stages in your working.

- 1 The ocean liner Queen Mary 2 is the longest of its type.
It has a length of 345 metres.

A scale model is made of the Queen Mary 2
The scale of the model is 1 : 200

Work out the length of the scale model.
Give your answer in centimetres.

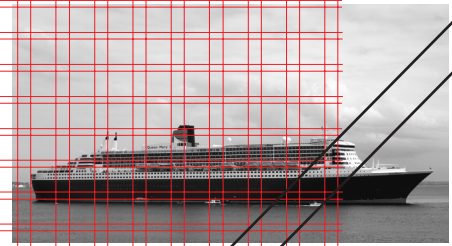

EXAMPLE

..... cm

(Total for Question 1 is 3 marks)



- 2 The pie chart gives information about the amounts spent by a gas company in one year.

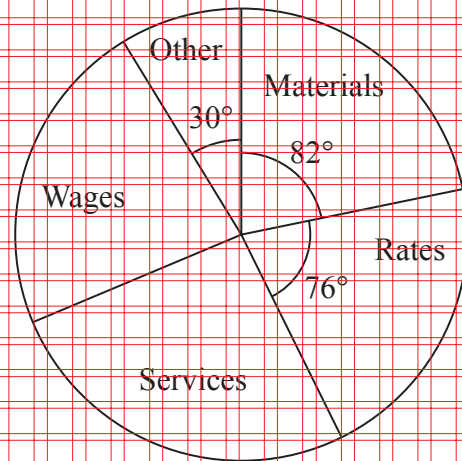

Diagram **NOT**
accurately drawn

The amount spent on materials was 225.5 million euros.

The amount spent on services was the same as the amount spent on wages.

Work out the amount spent on services.

..... million euros

(Total for Question 2 is 3 marks)



3 The first four terms of an arithmetic sequence are

5 9 13 17

(a) Write down an expression, in terms of n , for the n th term.

(b) Write down an expression, in terms of n , for the $(n + 1)$ th term.

(Total for Question 3 is 3 marks)



4 w, x, y and z are 4 integers written in order of size, starting with the smallest.

The mean of w, x, y and z is 13

The sum of w, x and y is 33

(a) Find the value of z .

$$z = \dots \dots \dots (2)$$

Given also that the range of w, x, y and z is 10

(b) work out the median of w, x, y and z .

(2)

(Total for Question 4 is 4 marks)



5 On 1st May 2012, the cost of 5.7 grams of gold was 15 960 rupees.

(a) Work out the cost, in rupees, of 4.6 grams of gold on the same day.

..... rupees

(2)

The cost of gold decreased by 7.5% from 1st May 2012 to 1st May 2013

(b) Work out the cost, in rupees, of 5.7 grams of gold on 1st May 2013

..... rupees

(3)

(Total for Question 5 is 5 marks)

Example



6 A steam engine for pulling trains has wheels of diameter 1.5 metres.

- (a) Calculate the circumference of a wheel.
Give your answer correct to 3 significant figures.

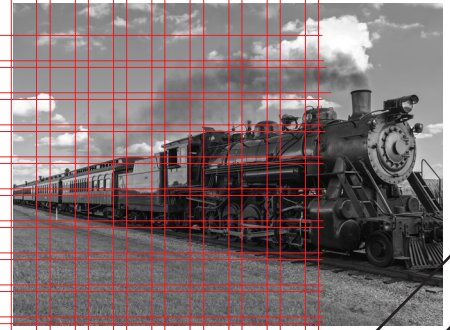

..... m

(2)

The steam engine travels 1000 metres along a test track.

- (b) Work out the number of complete turns of a wheel.

.....

(2)

(Total for Question 6 is 4 marks)



7 John changes £450 to euros.

The exchange rate is £1 = 1.16 euros.

(a) Change £450 to euros.

..... euros

(2)

When in Amsterdam, John uses his credit card to pay for a ring costing 850 euros.

He has to pay a bank charge of £3.50 for using his credit card in addition to the cost of the ring.

(b) Work out the total cost, in pounds (£), of the ring and the bank charge.

£

(3)

(Total for Question 7 is 5 marks)



8 Here is a right-angled triangle.

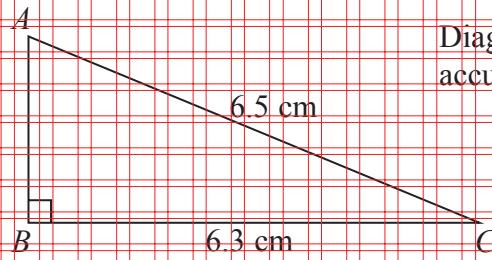

Diagram **NOT**
accurately drawn

$$AC = 6.5 \text{ cm.}$$

$$BC = 6.3 \text{ cm.}$$

$$\text{Angle } ABC = 90^\circ$$

Calculate the length of AB .

..... cm

(Total for Question 8 is 3 marks)



9 (a) Simplify $5y \times 4y^2$

(2)

(b) Simplify $\frac{15e^2f}{25ef^3}$

(2)

(c) Factorise $6p^2 - 5pq - 6q^2$

(2)

(d) Simplify

(1)

(Total for Question 9 is 7 marks)



10 The table shows some information about the five Great Lakes in North America.

Name	Surface area (m^2)	Volume of water (m^3)
Lake Erie	2.57×10^{10}	4.80×10^{11}
Lake Huron	6.01×10^{10}	3.52×10^{12}
Lake Michigan	5.80×10^{10}	4.87×10^{12}
Lake Ontario	1.91×10^{10}	1.64×10^{12}
Lake Superior	8.21×10^{10}	1.22×10^{13}

- (a) Work out the total surface area of the five Great Lakes.
Give your answer in standard form.

..... m^2
(2)

Loch Ness is the largest lake in Scotland.

The lake has a volume of water $67.45 \times 10^9 \text{ m}^3$.

The volume of water in Lake Superior is k times the volume of water in Loch Ness.

- (b) Work out the value of k .
Give your answer correct to 3 significant figures.

$k =$
(2)

(Total for Question 10 is 4 marks)



11 Here is a prism.

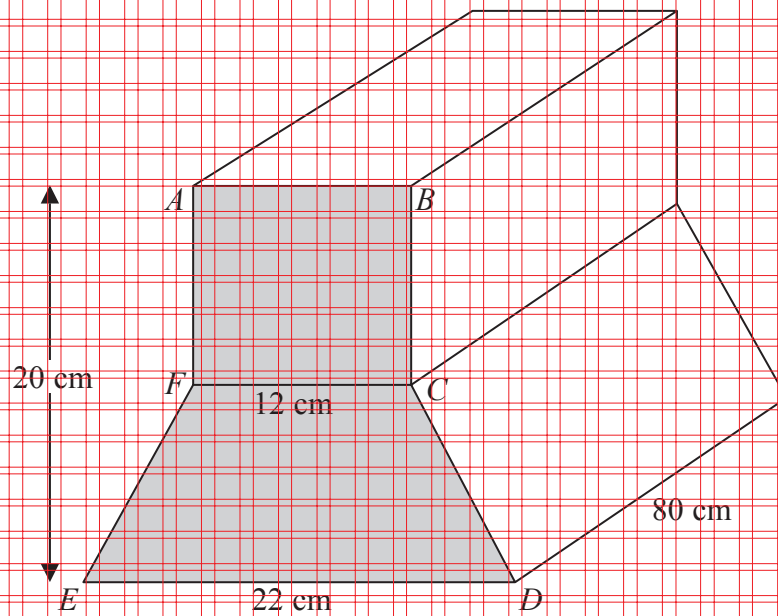

Diagram NOT
accurately drawn

$ABCDEF$ is a cross section of the prism.

$ABCF$ is a square of side 12 cm.

$FCDE$ is a trapezium.

$ED = 22$ cm.

The height of the prism is 20 cm.

The length of the prism is 80 cm.

Work out the total volume of the prism.

..... cm³

(Total for Question 11 is 5 marks)



P 4 4 3 8 8 A 0 1 3 2 8

12 There are 32 students in Mr Newton's class.
20 are boys and 12 are girls.

The mean height of the boys is 151 cm.

The mean height of the girls is 148 cm.

Calculate the mean height of all the students in Mr Newton's class.

..... cm

(Total for Question 12 is 3 marks)



13 (a) Solve

$$3x + 3y = 9$$

$$4x + 2y = 13$$

Show clear algebraic working.

$$x = \dots\dots\dots$$

$$y = \dots\dots\dots$$

(4)

L is a line parallel to the line with equation $4x + 2y = 13$

L passes through the point with coordinates $(3, -1)$

(b) Find an equation for the line L.

(3)

(Total for Question 13 is 7 marks)



14 (a) Factorise $a^2 - b^2$

(1)

$$N = 2^{22} - 1$$

(b) Write N as the product of two integers, both of which are greater than 1000

(2)

(Total for Question 14 is 3 marks)



15 $ABCD$ is a trapezium.

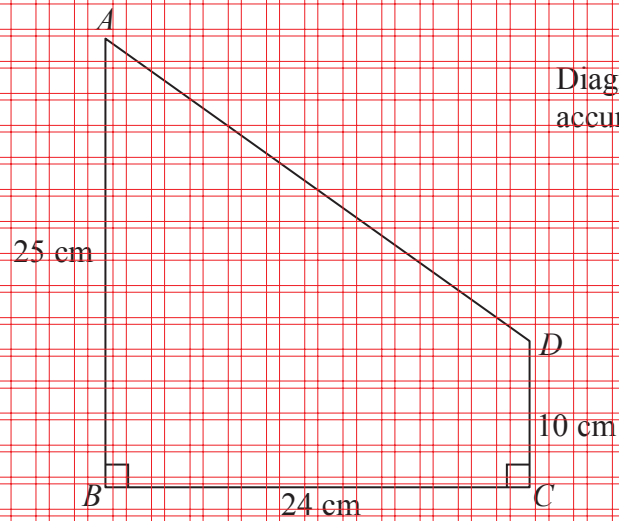

$$AB = 25 \text{ cm.}$$

$$BC = 24 \text{ cm.}$$

$$CD = 10 \text{ cm.}$$

$$\text{Angle } ABC = \text{angle } BCD = 90^\circ$$

Calculate the size of angle CDA .

Give your answer correct to 3 significant figures.

(Total for Question 15 is 4 marks)



P 4 4 3 8 8 A 0 1 7 2 8

16 (a) Complete the table of values for $y = \frac{1}{2}\left(x + \frac{9}{x}\right)$

x	1	1.5	2	3	4	5	6
y	5		3.25		3.125	3.4	

(b) Draw the graph of $y = \frac{1}{2}\left(x + \frac{9}{x}\right)$ for values of x from 1 to 6

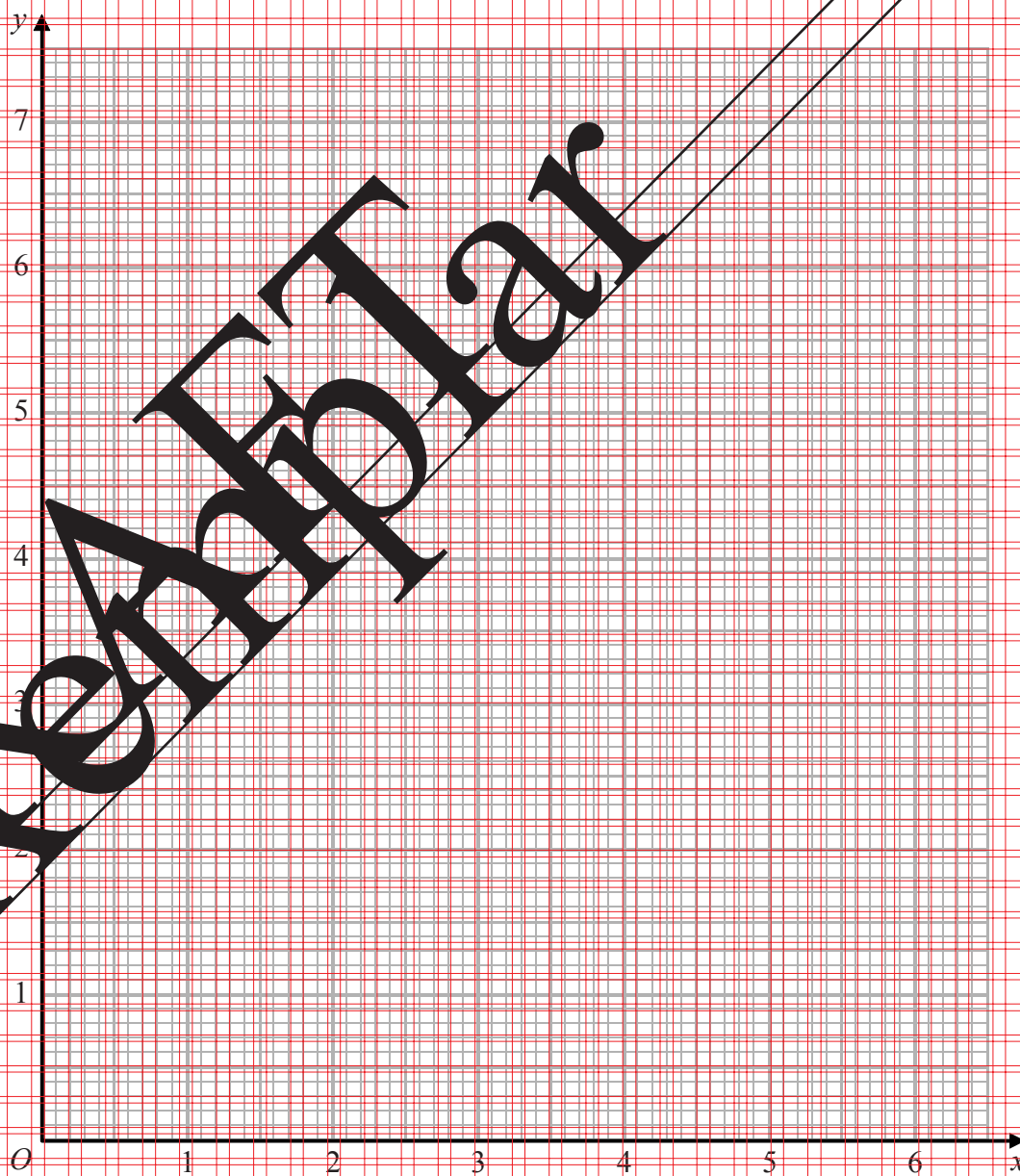

(c) Use the graph to find estimates for the solutions of the equation $x + \frac{9}{x} = 7$

(2)

(Total for Question 16 is 6 marks)

17 $f(x) = \frac{3}{x+1} + \frac{1}{x-2}$

(a) State one value of x which cannot be included in any domain of f .

(1)

(b) Find the value of $f(0)$

(1)

(c) Find the value of x for which $f(x) = 0$.
Show clear algebraic working.

$x =$

(3)

(Total for Question 17 is 5 marks)



18 $y = \frac{2a}{b-c}$

$a = 42$ correct to 2 significant figures.

$b = 24$ correct to 2 significant figures.

$c = 14$ correct to 2 significant figures.

Work out the lower bound for the value of y .

Give your answer correct to 2 significant figures.

Show your working clearly.

(Total for Question 18 is 3 marks)



19 The table gives information about the areas of some farms in France.

Area (A hectares)	Frequency
$0 < A \leq 20$	50
$20 < A \leq 50$	90
$50 < A \leq 100$	120
$100 < A \leq 300$	160

On the grid, draw a histogram to show this information.

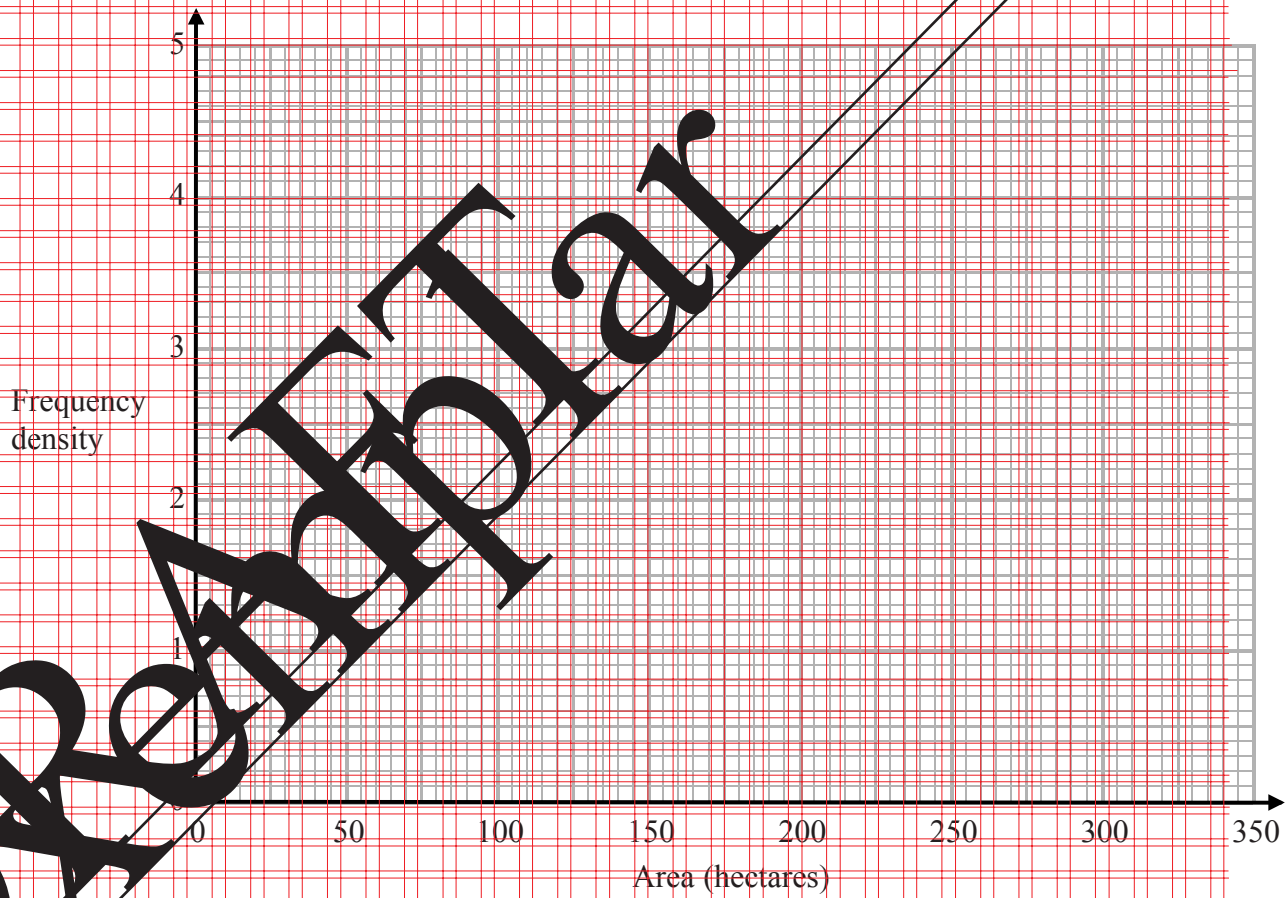

(Total for Question 19 is 3 marks)



20 Leonidas has a fair dice.

He throws the dice twice.

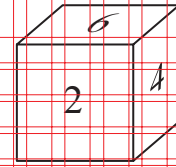

(a) Work out the probability that he gets the number 5 both times.

(2)

Alicia has a fair dice.

She throws the dice 3 times.

(b) Work out the probability that she gets the number 5 exactly once.

(3)

(Total for Question 20 is 5 marks)

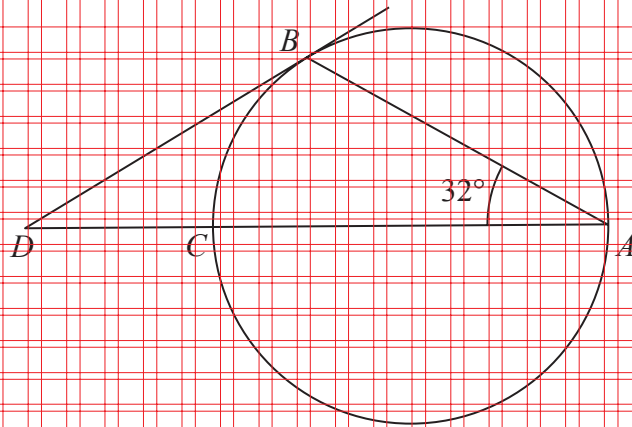

21

Diagram NOT
accurately drawn

A , B and C are three points on a circle.

DCA is a straight line.

CA is a diameter of the circle.

DB is a tangent to the circle.

Calculate the size of angle CDB .

(Total for Question 21 is 3 marks)



P 4 4 3 8 8 A 0 2 3 2 8

22 A , r and T are three variables.

A is proportional to T^2

A is also proportional to r^3

$T = 47$ when $r = 0.25$

Find r when $T = 365$

Give your answer correct to 3 significant figures.

(Total for Question 22 is 4 marks)

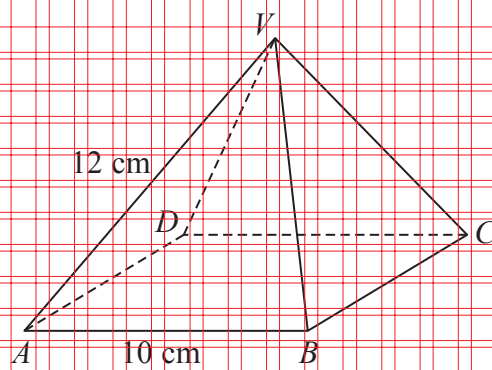

23

Diagram NOT
accurately drawn

$ABCD$ is the square base of the pyramid $VABCD$.

$AB = BC = CD = DA = 10$ cm.

$VA = VB = VC = VD = 12$ cm.

Calculate the height of the pyramid.

Give your answer correct to 3 significant figures.

..... cm

(Total for Question 23 is 4 marks)

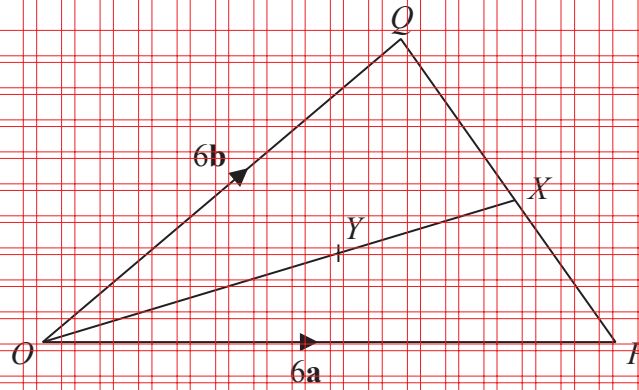

24

Diagram NOT
accurately drawn

In triangle OPQ , $\vec{OP} = 6\mathbf{a}$ and $\vec{OQ} = 6\mathbf{b}$

X is the midpoint of PQ .

- (a) Find, in terms of \mathbf{a} and \mathbf{b} , the vector \vec{OX}
Give your answer in its simplest form.

(2)

Y is the point on OX such that $OY = \frac{2}{3} OX$

- (b) Find, in terms of \mathbf{a} and \mathbf{b} , the vector \vec{OY}
Give your answer in its simplest form.

(2)

(Total for Question 24 is 4 marks)

TOTAL FOR PAPER IS 100 MARKS





EXAMPLE
LAST PAGE
Do NOT write in this space.



P 4 4 3 8 8 A 0 2 7 2 8

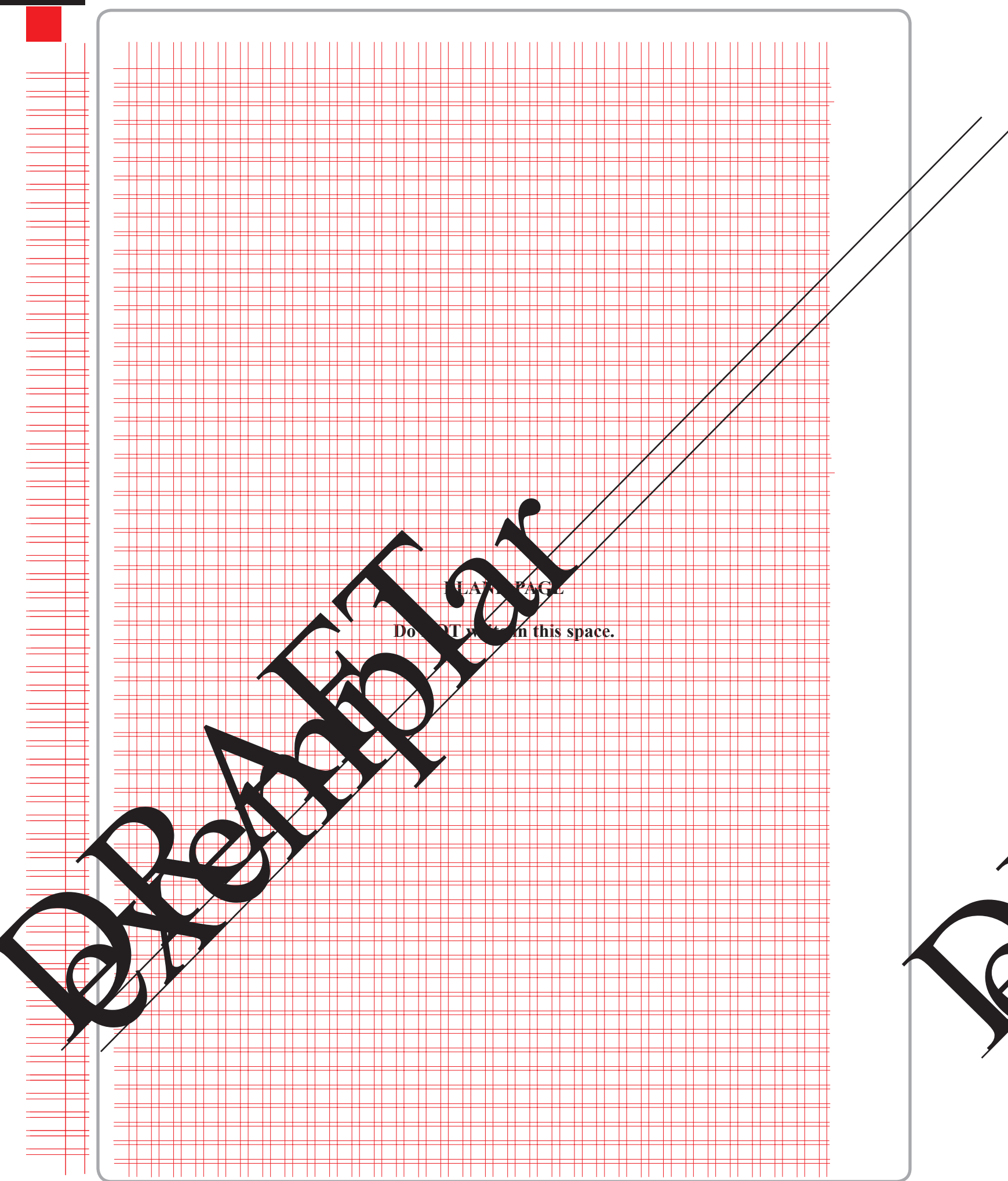

PLAN PAGE

Do NOT write in this space.

