

Write your name here

Surname

Other names

**Pearson Edexcel**  
**International GCSE**

Centre Number

--	--	--	--	--

Candidate Number

--	--	--	--

# Mathematics B

## Paper 1



Wednesday 14 May 2014 – Morning  
**Time: 1 hour 30 minutes**

Paper Reference

**4MB0/01**

**You must have:** Ruler graduated in centimetres and millimetres, protractor, compasses, pen, HB pencil, eraser, calculator. Tracing paper may be used.

Total Marks

### Instructions

- Use **black** ink or ball-point pen.
- **Fill in the boxes** at the top of this page with your name, centre number and candidate number.
- Answer **all** questions.
- Answer the questions in the spaces provided – *there may be more space than you need.*
- **Calculators may be used.**

### Information

- The total mark for this paper is 100.
- The marks for **each** question are shown in brackets – *use this as a guide as to how much time to spend on each question.*

### Advice

- Read each question carefully before you start to answer it.
- Check your answers if you have time at the end.
- Without sufficient working, correct answers may be awarded no marks.

Turn over ►

P43070A

©2014 Pearson Education Ltd.

1/1/1/

**PEARSON**

Answer ALL TWENTY-EIGHT questions.

Write your answers in the spaces provided.

You must write down all stages in your working.

1 Simplify  $\frac{4x + 12}{x^2 + 3x}$

.....  
(Total for Question 1 is 2 marks)

2

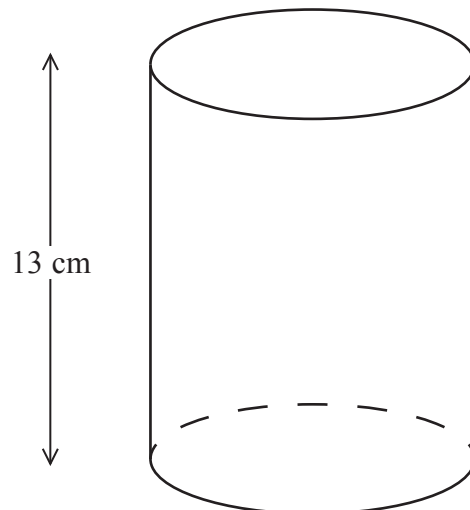

Diagram NOT  
accurately drawn

The volume of a right circular cylinder of height 13 cm is  $117\pi \text{ cm}^3$ .

Calculate, in cm, the radius of the cylinder.

..... cm

(Total for Question 2 is 2 marks)



- 3 Express 625 grams as a fraction of 1 kilogram. Give your answer in its simplest form.

.....  
(Total for Question 3 is 2 marks)

- 4 Calculate the size, in degrees, of an exterior angle of a 24-sided regular polygon.

.....  
(Total for Question 4 is 2 marks)

- 5 Solve  $\frac{2x}{x+3} = 1$

$x =$  .....

(Total for Question 5 is 2 marks)

- 6 Evaluate  $\frac{7.2 \times 10^{-3} - 8.4 \times 10^{-4}}{3.6 \times 10^{-1}}$ , giving your answer to

(a) 3 significant figures,

.....  
(1)

(b) 3 decimal places.

.....  
(1)

(Total for Question 6 is 2 marks)



7 The bearing of  $A$  from  $B$  is  $048^\circ$

Calculate the bearing of  $B$  from  $A$ .

.....  
(Total for Question 7 is 2 marks)

8 Simplify  $\left(\frac{a^6}{8}\right)^{\frac{2}{3}}$

.....  
(Total for Question 8 is 2 marks)

9 The  $n$ th term of a sequence is  $2n - 1$

Find the difference between the  $(n + 1)$ th term and the  $n$ th term of this sequence.

.....  
(Total for Question 9 is 2 marks)

10 Find the Highest Common Factor (HCF) of 30, 36 and 138

Show your working clearly.

.....  
(Total for Question 10 is 2 marks)



11 Make  $a$  the subject of  $(x - a)(x + b) = 3bx$

Write your answer as a single algebraic fraction.

$a = \dots\dots\dots$

(Total for Question 11 is 3 marks)

12

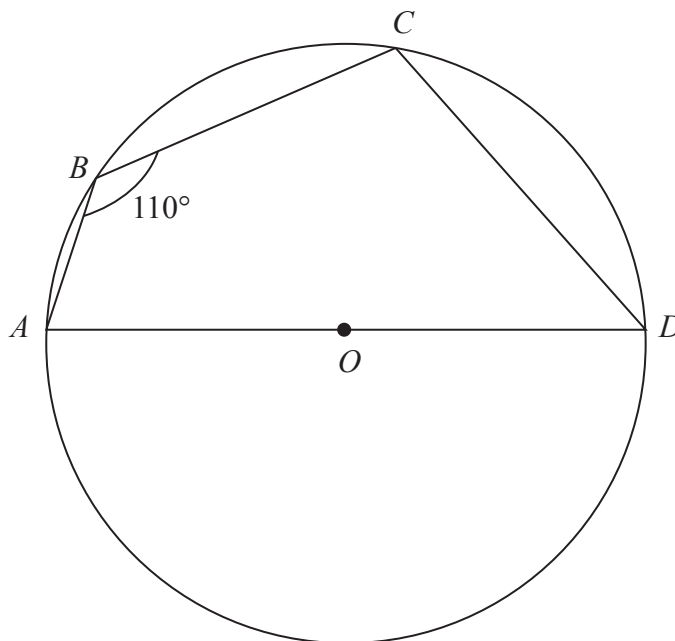

Diagram **NOT**  
accurately drawn

In the diagram,  $ABCD$  is a circle with centre  $O$  and diameter  $AD$ .  
Given that  $\angle ABC = 110^\circ$ , calculate the size, in degrees, of  $\angle COD$ .

Give reasons for your working.

(Total for Question 12 is 3 marks)



13 Express  $\sqrt{245} - \sqrt{45}$  in the form  $4\sqrt{m}$  where  $m$  is a prime number.

Show all your working.

(Total for Question 13 is 3 marks)

14 A cycle is travelling along a horizontal road. The diameter of each wheel of the cycle is 59 cm and each wheel makes 110 revolutions a minute.

Calculate the distance, in km to 3 significant figures, travelled by the cycle in one hour.

..... km

(Total for Question 14 is 3 marks)



15

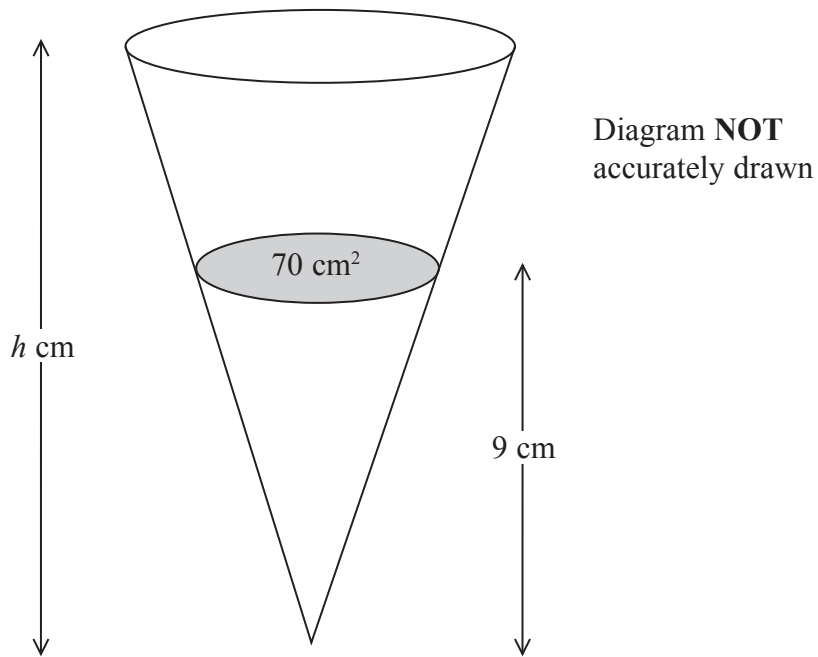

The diagram shows an inverted hollow right circular cone of height  $h$  cm.

The area of the open end of the cone is  $280 \text{ cm}^2$ . Water is poured into the cone to a height of  $9$  cm. The area of the surface of the water is  $70 \text{ cm}^2$ , as shown in the diagram.

Calculate the value of  $h$ .

$$h = \dots\dots\dots$$

(Total for Question 15 is 3 marks)



16  $y$  varies directly as the cube of  $x$ .

$$y = 9 \text{ when } x = 2$$

Find the value of  $x$  when  $y = 72$

$$x = \dots\dots\dots$$

(Total for Question 16 is 4 marks)

17 Solve the simultaneous equations

$$\begin{aligned} 2x - y &= 2 \\ x + 3y &= 15 \end{aligned}$$

$$x = \dots\dots\dots, y = \dots\dots\dots$$

(Total for Question 17 is 4 marks)





- 18 The time at which the first goal was scored in a number of football matches was recorded.

The incomplete table and histogram give information about the time interval in which the first goal was scored and the number of matches in which the first goal was scored in that interval.

Time ( $t$ ) in minutes	Number of matches
$0 < t \leq 40$	20
$40 < t \leq 45$	35
$45 < t \leq 55$	50
$55 < t \leq 75$	
$75 < t \leq 90$	

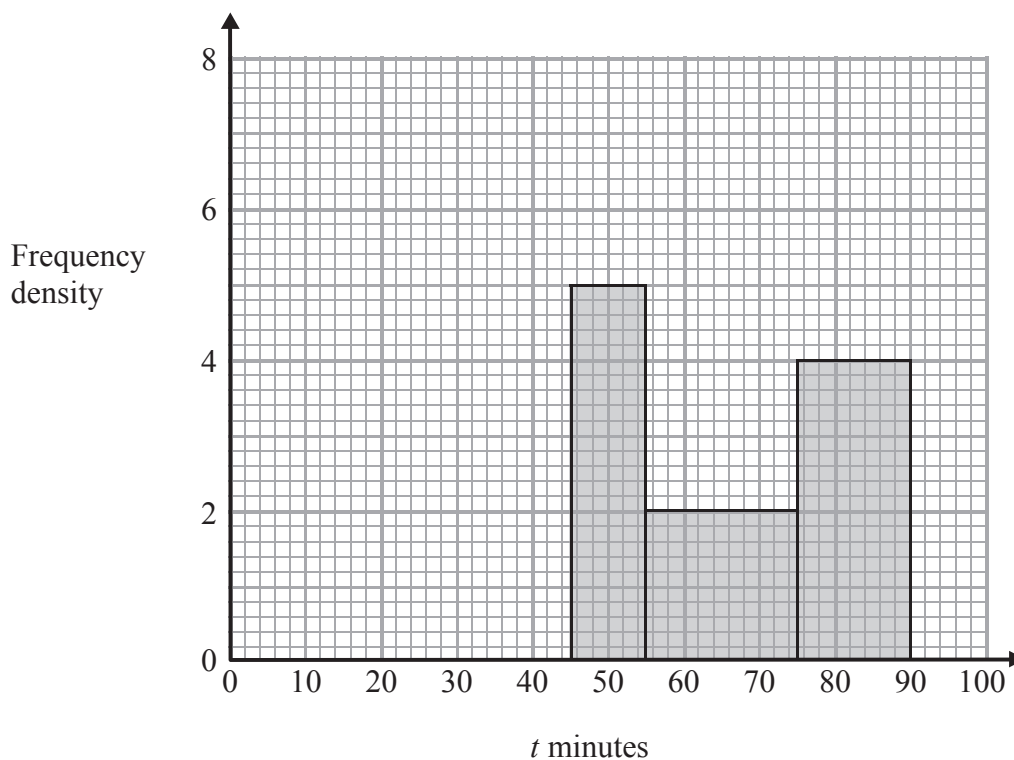

- (a) Use the histogram to complete the table.

(2)

- (b) Use the table to complete the histogram.

(2)

(Total for Question 18 is 4 marks)



19 A mixture of sand and cement is to be used to plaster a wall.

In the original mixture, the ratio of sand to cement by weight is 3 : 1

Given that the weight of sand used is 9 kg,

(a) write down the weight, in kg, of cement used in the original mixture.

..... kg  
(1)

It is decided to use the same weight of cement but to change the ratio of sand to cement by weight to 5 : 1 for a new mixture.

(b) Calculate the weight of sand, in kg, that has to be added to the original mixture to make the new mixture.

..... kg  
(3)

(Total for Question 19 is 4 marks)

20 Solve the equation

$$4x^2 - 3x - 2 = 0$$

Give your solutions to 3 significant figures.

.....

(Total for Question 20 is 4 marks)



21 Some workers were asked how they travel to work.

Of these workers

38 travel to work by bus ( $B$ ),

27 travel to work by train ( $T$ ),

5 do not travel to work by bus or by train,

$x$  travel to work by both bus and train.

(a) Using this information, complete the Venn diagram, giving your answers in terms of  $x$  where appropriate.

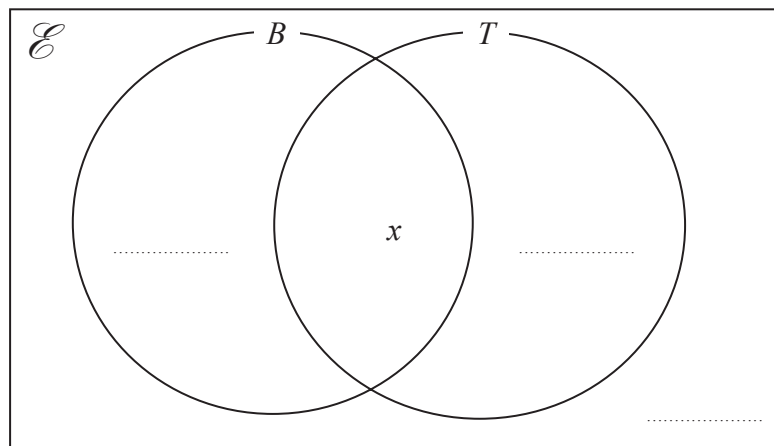

(1)

Given that the number of workers asked is 50,

(b) calculate the value of  $x$ .

$$x = \dots\dots\dots$$

(2)

One of the workers is chosen at random.

(c) Find the probability that this worker travels to work only by bus.

.....

(2)

(Total for Question 21 is 5 marks)



22 The coordinates of  $A$  are  $(1, 1)$  and the coordinates of  $B$  are  $(2, 3)$ .

(a) Write down the vector  $\vec{AB}$  in the form  $\begin{pmatrix} m \\ n \end{pmatrix}$ , where  $m$  and  $n$  are integers.

$\begin{pmatrix} \phantom{m} \\ \phantom{n} \end{pmatrix}$

(1)

(b) Given that  $2\vec{AB} = \vec{AC}$ , find the coordinates of  $C$ .

$C(\dots\dots\dots, \dots\dots\dots)$

(2)

(c) Calculate the modulus, to 3 significant figures, of  $\vec{AC}$ .

$\dots\dots\dots$

(2)

**(Total for Question 22 is 5 marks)**



23

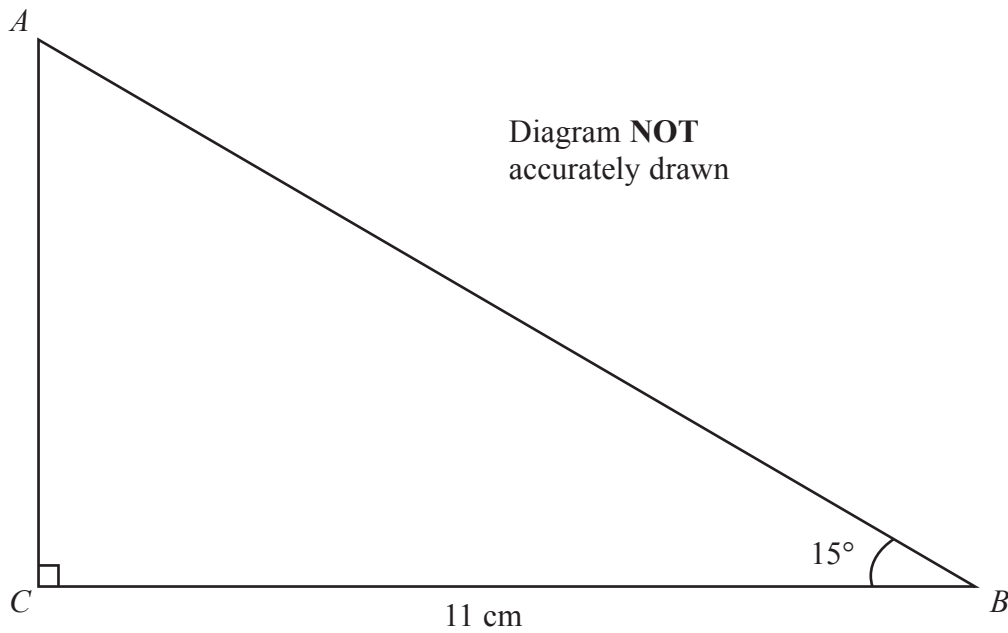

The diagram shows a right-angled triangle  $ABC$ , with  $BC = 11$  cm and  $\angle ABC = 15^\circ$

(a) Calculate the length, in cm to 3 significant figures, of  $AB$ .

..... cm  
(2)

The point  $D$  on  $AB$  is such that  $AD = AC$ .

(b) Calculate the length, in cm to 3 significant figures, of  $DB$ .

..... cm  
(3)

(Total for Question 23 is 5 marks)



24

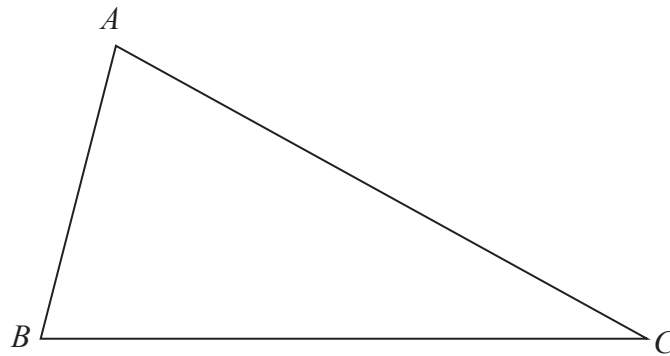

The diagram shows  $\triangle ABC$ .

Leaving in all your construction lines, construct

- (a) the perpendicular bisector of  $BC$ , (2)
- (b) the bisector of  $\angle ABC$ . (2)

The region **R** within  $\triangle ABC$  is the set of points that are closer to  $BC$  than to  $AB$  and are closer to  $B$  than to  $C$ .

- (c) Show, by shading, the region **R**. Label the region **R**. (1)

(Total for Question 24 is 5 marks)



25 A shop sells potatoes in small bags and in large bags.

The weight of the potatoes in a small bag is 2.5 kg and the cost of a small bag is £1.00

(a) Calculate the cost, in £, of 1 kg of the potatoes in a small bag.

£ .....  
(2)

The weight of the potatoes in a large bag is 20% more than the weight of the potatoes in a small bag. The cost of a large bag is 11% more than the cost of a small bag.

(b) Calculate the cost, in £, of 1 kg of the potatoes in a large bag.

£ .....  
(3)

(Total for Question 25 is 5 marks)

26 (a) Show that  $(x + 3)$  is a factor of  $2x^3 + 13x^2 + 27x + 18$

(2)

(b) Hence factorise completely  $2x^3 + 13x^2 + 27x + 18$

.....  
(4)

(Total for Question 26 is 6 marks)







Calculate the probability that the archer will

(b) hit the target with his first shot but miss the target with his second shot,

.....  
(2)

(c) hit the target at least once if he takes both shots.

.....  
(3)

**(Total for Question 27 is 7 marks)**

---

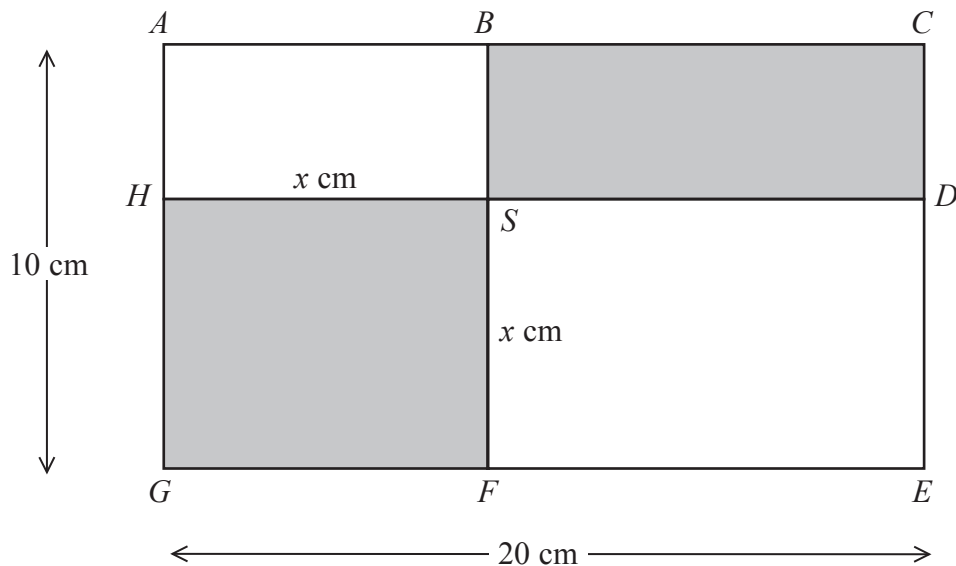

28

Diagram NOT  
accurately drawn

The diagram shows a rectangle  $ACEG$  of length  $20\text{ cm}$  and width  $10\text{ cm}$ .

The rectangle  $BCDS$  and the square  $HSGF$  are shown shaded.

The square  $HSGF$  has sides of length  $x\text{ cm}$ .

The total area of the rectangle  $BCDS$  and the square  $HSGF$  is  $y\text{ cm}^2$ .

(a) Show that  $y = 2x^2 - 30x + 200$

(2)

(b) Find the value of  $x$  for which  $y$  is a minimum.

$x = \dots\dots\dots$

(3)



(c) Hence find the minimum total area, in  $\text{cm}^2$ , of the rectangle  $BCDS$  and the square  $HSFG$ .

.....  $\text{cm}^2$   
(2)

(Total for Question 28 is 7 marks)

---

**TOTAL FOR PAPER IS 100 MARKS**



**BLANK PAGE**

**Do NOT write on this page.**

