

Write your name here

Surname

Other names

**Edexcel Primary and
Lower Secondary
Curriculum**

Centre Number

--	--	--	--	--

Candidate Number

--	--	--	--

Science

Year 6 Achievement Test

Wednesday 13 June 2012 – Morning
Time: 1 hour

Paper Reference

JSC01

You do not need any other materials.

Total Marks

Instructions

- Use **black** ink or ball-point pen.
- **Fill in the boxes** at the top of this page with your name, centre number and candidate number.
- Answer **all** questions.
- Answer the questions in the spaces provided
– *there may be more space than you need.*

Information

- The total mark for this paper is 60.
- The marks for **each** question are shown in brackets
– *use this as a guide as to how much time to spend on each question.*
- Candidates may use a calculator.

Advice

- Read each question carefully before you start to answer it.
- Try to answer every question.
- Check your answers if you have time at the end.

Turn over ►

P41326A

©2012 Pearson Education Ltd.

6/5/13/

PEARSON

SECTION A

Answer ALL questions.

For questions 1 – 8 put a cross in one box ☒ to indicate your answer.

If you change your mind, put a line through the box ~~☒~~ and then put a cross in another box ☒.
Each question is worth one mark.

1 Jason's cat chases mice.



Jason bought a wind-up toy for the cat.

The toy looked like a mouse.

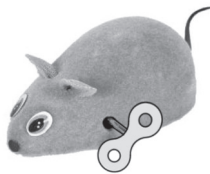

What can the real mouse and the toy mouse both do?



- A breathe
- B grow
- C move
- D reproduce

(Total for Question 1 = 1 mark)

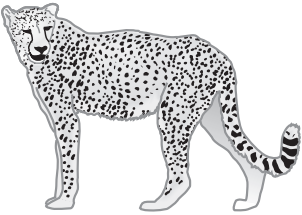

2 Some organisms are adapted to live on land.

Which of the following organisms is adapted to live on land?

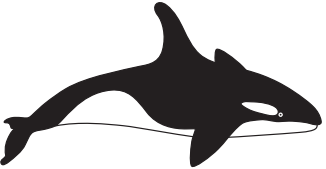
<input type="checkbox"/> A	
<input type="checkbox"/> B	
<input type="checkbox"/> C	
<input type="checkbox"/> D	

(Total for Question 2 = 1 mark)



- 3** A class was growing small plants. They decided to test different environmental conditions. After two weeks, the class looked at their plants and wrote down what they saw.

Group	Amount of light	Amount of water	After two weeks
1	Plenty	Little	Plants were small and brown
2	Plenty	Plenty	Plants were tall and green
3	Little	Plenty	Plants were very tall and pale green/yellow

Which statement is most likely to be true?

- A** Plants grow stronger with plenty of water and light.
- B** Plants grow stronger with plenty of water.
- C** Plants grow stronger with plenty of light.
- D** Water and light do not affect plant growth.

(Total for Question 3 = 1 mark)



4 Sam wrote some facts about rabbits in his book.

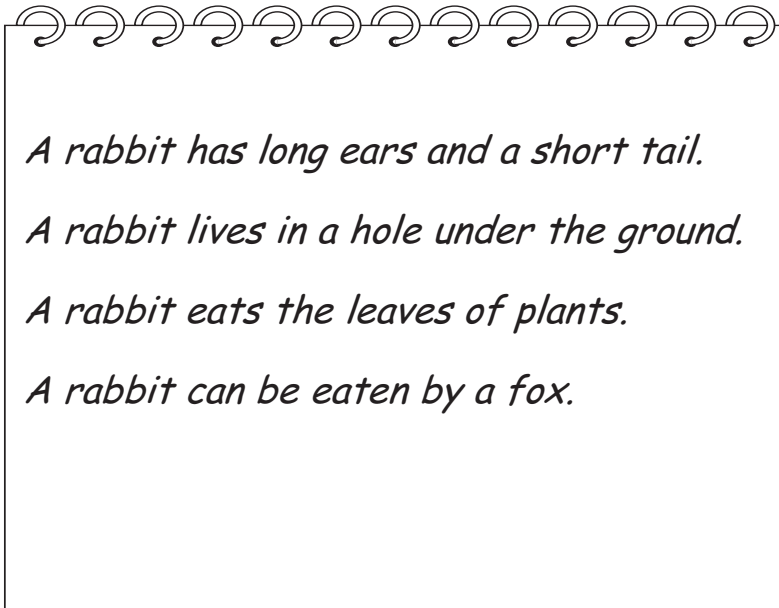

Which sentence describes the rabbit's habitat?

- A A rabbit has long ears and a short tail.
- B A rabbit lives in a hole under the ground.
- C A rabbit eats the leaves of plants.
- D A rabbit can be eaten by a fox.

(Total for Question 4 = 1 mark)



5 Look at the picture of a cat's teeth.

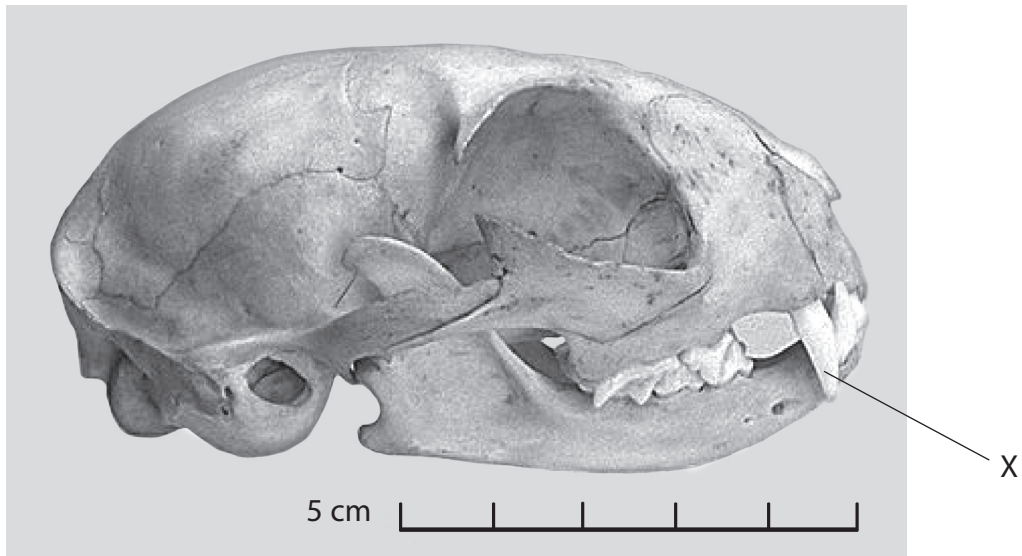

Which type of teeth are labelled X?

- A incisors
- B canines
- C premolars
- D molars

(Total for Question 5 = 1 mark)



6 Look at the diagram below.

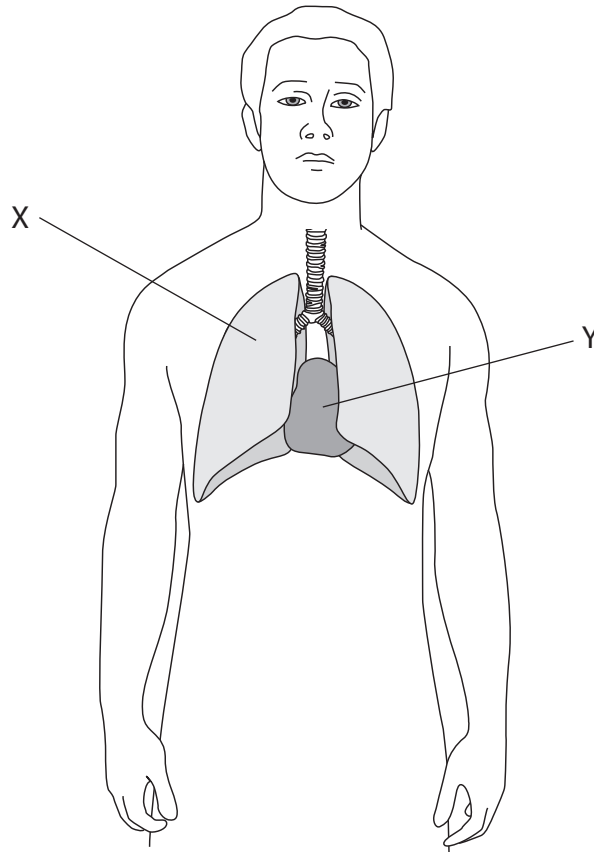

Which organs are labelled X and Y?

	X	Y
<input type="checkbox"/> A	Heart	Lung
<input type="checkbox"/> B	Lung	Stomach
<input type="checkbox"/> C	Stomach	Heart
<input type="checkbox"/> D	Lung	Heart

(Total for Question 6 = 1 mark)



7 The following organisms are part of a food chain.

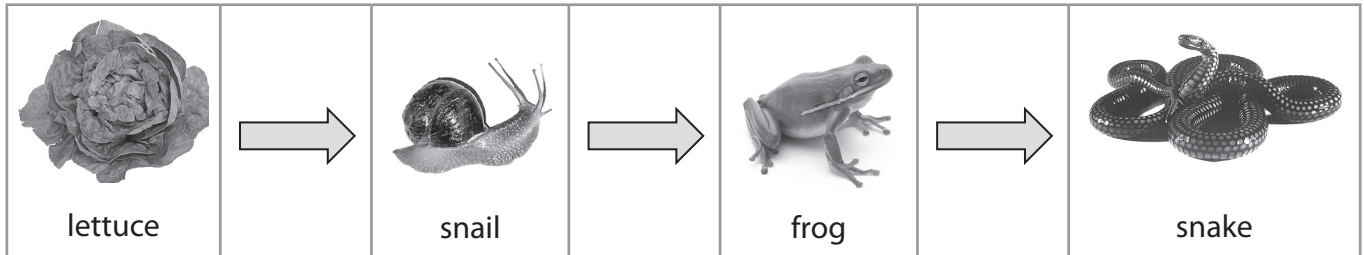

Which organism is the producer?

- A frog
- B lettuce
- C snail
- D snake

(Total for Question 7 = 1 mark)

8 Which of these statements about pollination is true?

- A At pollination, pollen sticks to the anther.
- B Flowers are always pollinated by insects.
- C Flowers are never pollinated by the wind.
- D At pollination, pollen sticks to the stigma.

(Total for Question 8 = 1 mark)



9 This is a diagram of a tooth.

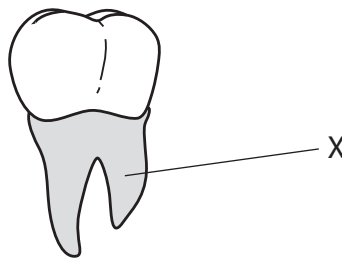

- (a) Name the part of the tooth labelled X?..... (1)
- (b) Give **one** thing people do to keep their teeth healthy and prevent decay. (1)

.....

.....

(Total for Question 9 = 2 marks)

10 Blood vessels carry blood around the body.

- (a) Blood vessels that carry blood **away from the heart** are called (1)
- (b) Blood vessels that carry blood **to the heart** are called (1)

.....

(Total for Question 10 = 2 marks)



For questions 11 – 19 put a cross in one box ☒ to indicate your answer.
If you change your mind, put a line through the box ☒ and then put a cross in another box ☒.
Each question is worth one mark.

11 Modern aircraft are made of aluminium, this is because it is



- A brittle.
- B lightweight.
- C elastic.
- D magnetic.

(Total for Question 11 = 1 mark)



12 The diagram shows an electrical cable.

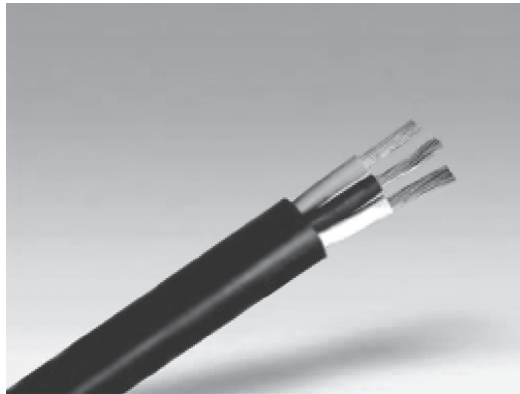

It is made of two different materials, plastic and copper wire.



Which of the following sentences explains why these two materials are used?

- A Copper and plastic are both good conductors of electricity.
- B Copper is a good conductor of electricity but plastic is not.
- C Copper and plastic are both good electrical insulators.
- D Plastic is a good conductor of electricity but copper is not.

(Total for Question 12 = 1 mark)

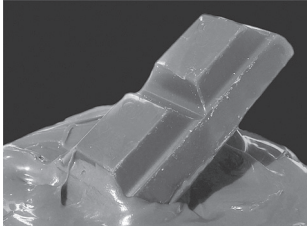

13 Which of the following is an **irreversible** change?

- | | |
|----------------------------|---|
| <input type="checkbox"/> A | 
an egg cooking |
| <input type="checkbox"/> B | 
a chocolate bar melting |
| <input type="checkbox"/> C | 
an ice cube freezing |
| <input type="checkbox"/> D | 
a pan of water boiling |

(Total for Question 13 = 1 mark)



14 The diagram shows the different changes of state.

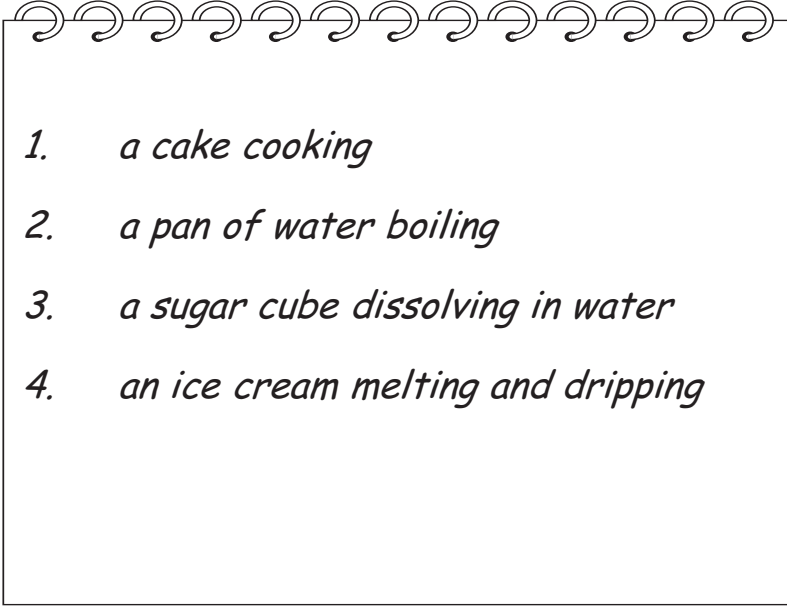

Which statements are examples of changes of state?

- 
1. *a cake cooking*
 2. *a pan of water boiling*
 3. *a sugar cube dissolving in water*
 4. *an ice cream melting and dripping*

- A 1 and 2
- B 2 and 4
- C 2 and 3
- D 1, 3 and 4

(Total for Question 14 = 1 mark)

15 Condensation is a change of state from

- A gas to liquid.
- B liquid to solid.
- C liquid to gas.
- D gas to solid.

(Total for Question 15 = 1 mark)



16 A statue is being made for a town.

It needs to be carved.

It must last for a long time.

Here is some information about different types of rock that the statue could be made from.

Using the information, which rock would be best to use for the statue?

Rock	Information
<input type="checkbox"/> A	It crumbles when carved. It soaks in (absorbs) water.
<input type="checkbox"/> B	It is difficult to carve. It does not soak in (absorb) water.
<input type="checkbox"/> C	It is easy to carve. It soaks in (absorbs) water very easily.
<input type="checkbox"/> D	It is easy to carve. It does not soak in (absorb) water.

(Total for Question 16 = 1 mark)

17 Which sentence about solids, liquids and gases is true?

- A** All gases have the same volume.
- B** Only liquids take the shape of their container.
- C** Solids and liquids have a definite shape.
- D** Gases and liquids take the shape of their container.

(Total for Question 17 = 1 mark)



18 Rabia was stirring some salt into water. She noticed that the salt disappeared.



Which word best describes the salty water?

- A insoluble
- B soluble
- C solution
- D solvent

(Total for Question 18 = 1 mark)



19 The picture shows a candle burning.



Which of these substances is needed for the candle to burn?

- A carbon dioxide
- B nitrogen
- C oxygen
- D water

(Total for Question 19 = 1 mark)



20 Draw a line to match the best material for each of these uses.

Used for building walls as it is strong and can be joined together.

Used for windows as light passes through it easily.

Used to make water pipes as it is strong, but easy to shape into hollow, watertight tubes.

glass

paper

metal

brick

(Total for Question 20 = 3 marks)



21 Afza sprayed some perfume in the corner of a room.

She could smell the perfume straight away.

Tom was on the other side of the room.

He could not smell the perfume at first, but he could after a short while.

Use your knowledge about gases to explain why Afza smelt the perfume straight away, and Tom smelt it later.

.....

.....

.....

.....

.....

.....

.....

.....

(Total for Question 21 = 3 marks)



For questions 22 – 31 put a cross in one box to indicate your answer.
If you change your mind, put a line through the box and then put a cross in another box .
Each question is worth one mark.

22 Amy has a hairdryer.



She drew a diagram of the circuit inside the hairdryer.

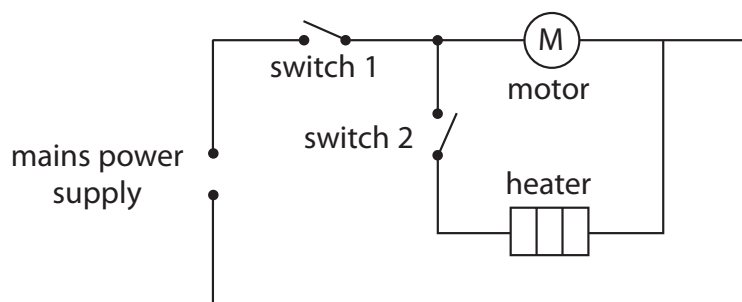

Which of the switches must be closed for the heater to work?

- A switch 1 only
- B switch 2 only
- C both switch 1 and switch 2
- D neither switch 1 nor switch 2

(Total for Question 22 = 1 mark)

23 Complete the sentence to explain how a shadow is formed.

A shadow is formed when.....

- A light passes through a transparent material.
- B light passes through an opaque material.
- C light is blocked by a transparent material.
- D light is blocked by an opaque material.

(Total for Question 23 = 1 mark)



24 Freya was using a magnet to sort out these materials.

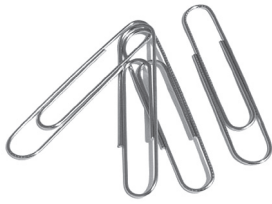

steel paperclip



copper coin



plastic clothes peg



rubber ball

Which sentence best describes what Freya found out?

- A All the objects stuck to the magnet.
- B All the metal objects stuck to the magnet.
- C Some of the metal objects stuck to the magnet.
- D None of the objects stuck to the magnet.

(Total for Question 24 = 1 mark)

25 Which of the following are **all** sources of light?

- A The sun, a mirror and an electric torch.
- B The sun, a candle and an electric torch.
- C The sun, a mirror and a candle.
- D A mirror, a candle and an electric torch.

(Total for Question 25 = 1 mark)



26 Lydia wanted a cup that would keep her drink cold for a long time.

She tested four cups by adding 50 ml of cold drink and putting the cups out in the sunshine.

She then measured the temperature of the drink after 20 minutes.

Her results are in the table below:

Cup material	Start temperature (°C)	End temperature (°C)
ceramic	5	19
polystyrene	5	13
metal	5	24
plastic	5	14

What is the correct order of materials, from the best insulator to the worst?

- A ceramic, polystyrene, plastic, metal
- B metal, ceramic, plastic, polystyrene
- C polystyrene, plastic, ceramic, metal
- D polystyrene, plastic, metal, ceramic

(Total for Question 26 = 1 mark)

27 Which of the following statements about **friction** is true?

- A It only occurs between solids.
- B It makes surfaces colder.
- C It only occurs on rough surfaces.
- D It only occurs when surfaces touch each other.

(Total for Question 27 = 1 mark)



28 James was walking his dog on a lead.



If James and the dog are walking at a steady speed, in a straight line then which sentence is true?

- A The pull from the dog on the lead is balanced by the pull from James.
- B Only James pulls on the lead.
- C The pull from the dog on the lead is smaller than the pull from James.
- D Only the dog pulls on the lead.

(Total for Question 28 = 1 mark)



29 Jake plays the guitar. He tunes his guitar by tightening or loosening the strings.



Which statements are correct?

1. *A tighter string makes a higher pitched note.*
2. *A looser string make a quieter sound.*
3. *A tighter string makes a louder sound.*
4. *A looser string makes a lower pitched note.*

- A 1 and 3
- B 2 and 4
- C 1 and 4
- D 1 and 2

(Total for Question 29 = 1 mark)



30 This diagram shows the orbit of the Earth around the Sun.

How long does it take the Earth to make one orbit of the Sun?

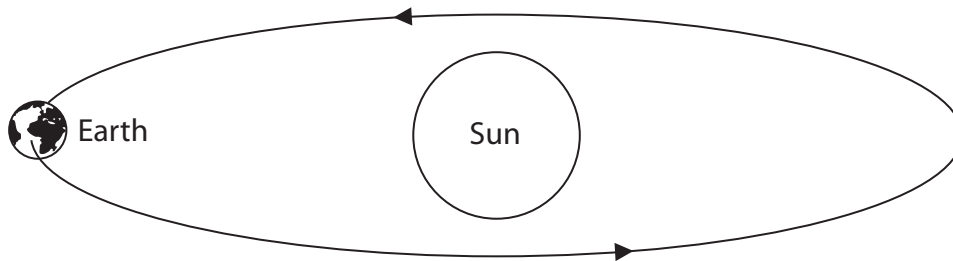

- A** one day
- B** one week
- C** one month
- D** one year

(Total for Question 30 = 1 mark)

31 Look at the diagram of an electrical circuit.

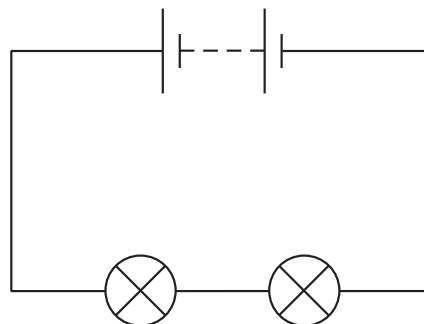

Which of the following changes will make the bulbs brighter?

- A** Making the wires longer.
- B** Adding another cell to the circuit.
- C** Adding another bulb.
- D** Removing a cell from the circuit.

(Total for Question 31 = 1 mark)



32 Hannah and Felix were investigating how shadows change. They put a stick into the ground and observed how its shadow changed at different times of day.

(a) How is a shadow formed?

(2)

.....

.....

.....

They looked at the shadow in the morning.
At noon the length of the shadow had changed.

(b) Use your knowledge about the position of the Sun to explain why the length of the shadow changed.

(2)

.....

.....

.....

.....

(Total for Question 32 = 4 marks)



33 Charlie was listening to music in his bedroom. His brother Kurt was in the room next door.

(a) Why did the music sound louder to Charlie? (1)

.....

.....

(b) Complete the sentence by choosing the best word from the box. (1)

The sound wave travelled to Charlie's ear as a

force	vibration	movement	ripple
-------	-----------	----------	--------

(c) (i) Kurt has normal hearing, but could not hear the music clearly. Why not? (1)

.....

.....

(ii) Kurt put his ear to the bedroom wall.
Why could he hear the music more clearly now? (1)

.....

.....

(Total for Question 33 = 4 marks)

TOTAL FOR SECTION A = 45 MARKS



BLANK PAGE



SECTION B



Answer ALL questions.

34 A class did an investigation to see which shoes have the best grip on the classroom floor.

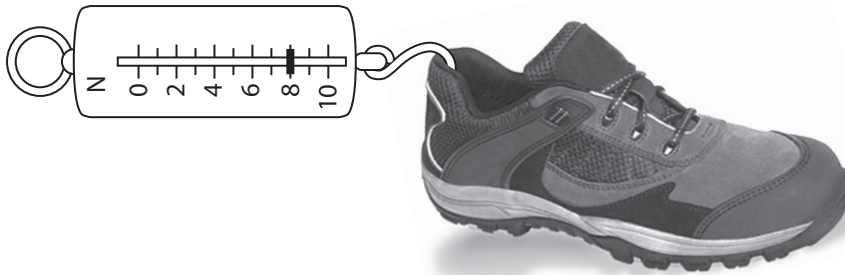
They attached a forcemeter to three types of shoe and measured the force needed to make the shoe move along the floor.



They started to record the results in this table.

Type of shoe	Force needed to make it move (N)
 school shoe	5
 ballet shoe	1
 trainer

(a) Add the forcemeter reading for the trainer to the table.

(1)



(b) What unit does the N on the forcemeter stand for?

(1)

(c) What is the name of the force between the floor and the shoe?

(1)

(d) Explain the results in terms of this force.

(2)

(Total for Question 34 = 5 marks)



P 4 1 3 2 6 A 0 2 9 3 6

35 Aisha wanted to find out if water cooled at a different rate in different sized beakers.

She used three beakers:



small beaker



medium beaker

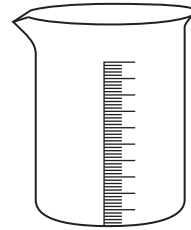

large beaker

She filled each beaker with water at 85°C at the start of the experiment.

She took the temperature of the water in each beaker every 5 minutes for 30 minutes.

Her results are shown in the table:

Time (minutes)	Temperature ($^{\circ}\text{C}$)		
	Small beaker	Medium beaker	Large beaker
0	85	85	85
5	75	80	81
10	68	74	77
15	64	71	74
20	60	68	71
25	57	65	69
30	54	63	66

(a) What was the temperature of the water in the medium beaker after 20 minutes?
Give the unit.

(2)



Aisha started to plot a graph of her results.

She plotted the results for the small beaker and for the medium beaker.

She noticed that there was a difference in the results for these two beakers.

Here is Aisha's graph.

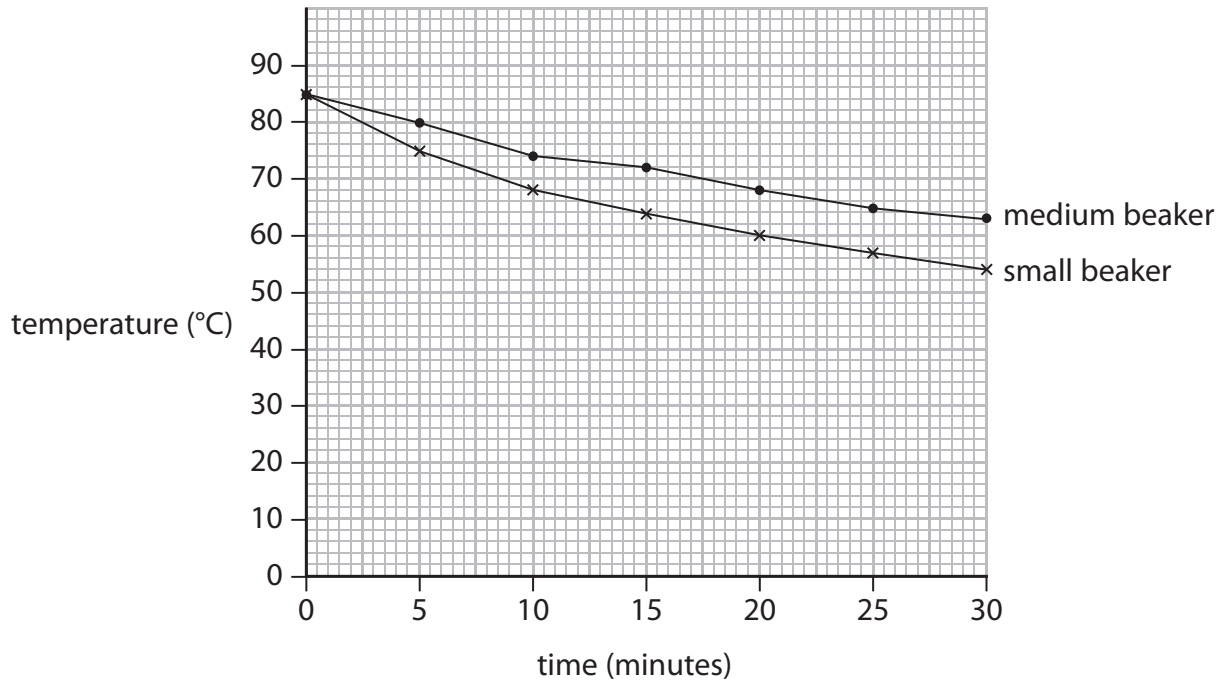

(b) (i) Describe how the pattern of the results is **similar** in both beakers.

(1)

(ii) Describe how the pattern of the results **differs** in the two beakers.

(2)

(c) Look at the results for the large beaker in the table.

Describe the pattern of these results.

(2)

(Total for Question 35 = 7 marks)



36 Some scientists collected data about four different types of penguin.

They found out the average mass of each type of penguin. They recorded this next to the name of each penguin as shown below.



Emperor Penguin 29 kg



King Penguin 16 kg

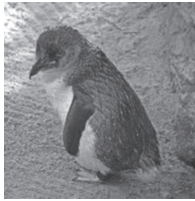

Southern Blue Penguin 2 kg

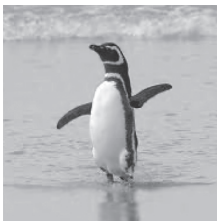

Magellanic Penguin 5 kg



Draw a bar chart to show the mass of each penguin.

(3)

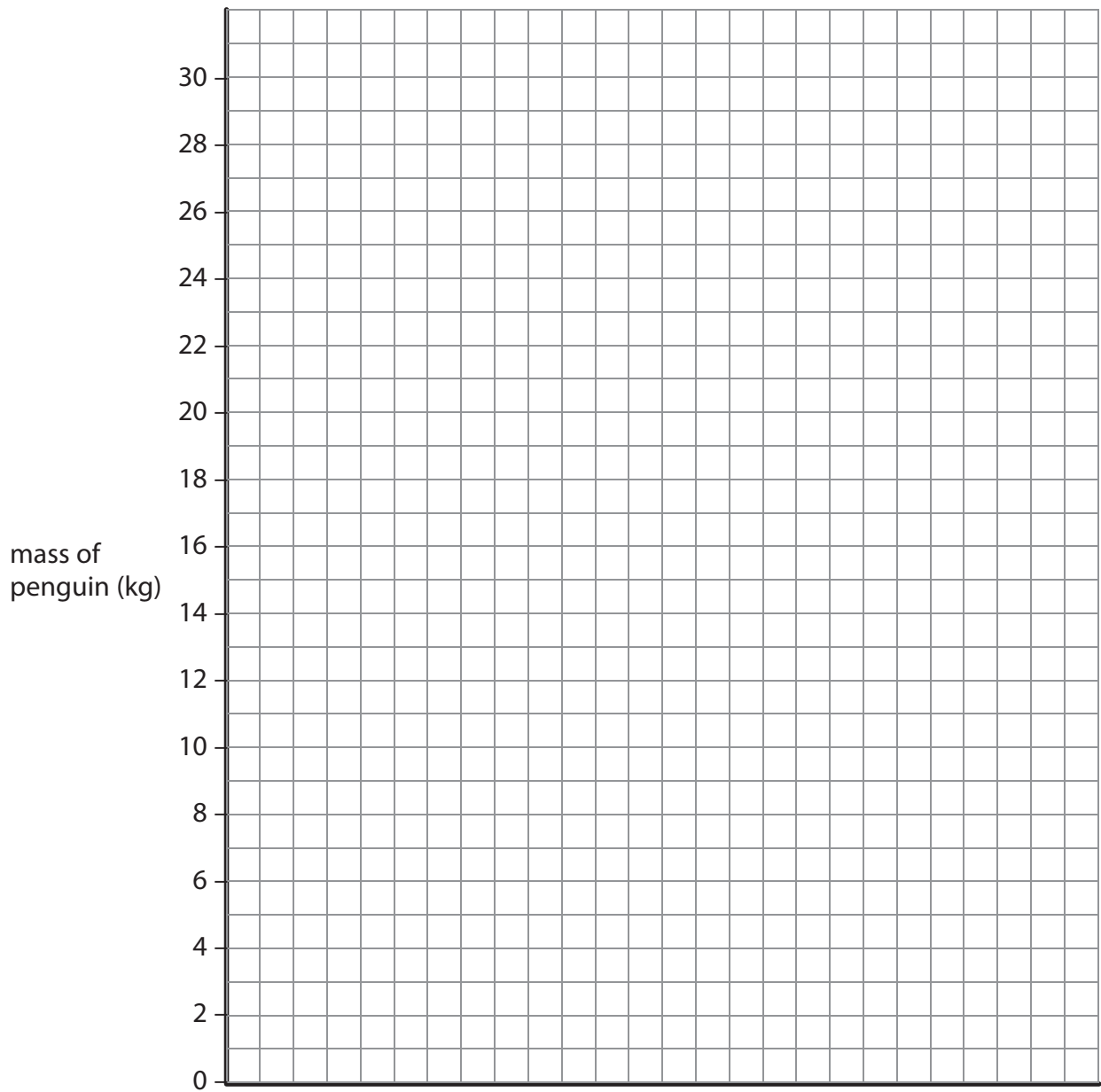

(Total for Question 36 = 3 marks)

TOTAL FOR SECTION B = 15 MARKS

TOTAL FOR PAPER = 60 MARKS



BLANK PAGE



BLANK PAGE



BLANK PAGE

