

Surname	Centre Number	Candidate Number
Other Names		0

**GCSE**

4121/01



S15-4121-01

**DESIGN AND TECHNOLOGY****UNIT 1****FOCUS AREA: Systems and Control Technology**

A.M. TUESDAY, 19 May 2015

2 hours

For Examiner's use only		
Question	Maximum Mark	Mark Awarded
<b>Section A</b>	1.	15
	2.	10
	3.	10
	4.	25
<b>Section B</b>	5.	10
	6.	15
	7.	20
	8.	15
<b>Total</b>	<b>120</b>	

4121  
010001**ADDITIONAL MATERIALS**

You will need basic drawing equipment, coloured pencils and a calculator for this examination.

**INSTRUCTIONS TO CANDIDATES**

Use black ink or black ball-point pen.

Write your name, centre number and candidate number in the spaces at the top of this page.

Answer **all** questions.

Write your answers in the spaces provided in this booklet. Where the space is not sufficient for your answer, continue at the back of the book, taking care to number the continuation correctly.

You are reminded of the necessity for good English and orderly presentation in your answers.

**INFORMATION FOR CANDIDATES**

The number of marks is given in brackets at the end of each question or part-question.

**Section A**

Marked out of 60 60 minutes

1. This question is about Product Analysis. It is worth a total of 15 marks.

A mechanical punch has been designed to make plectrums for guitars from unwanted items such as bank cards, carton lids and other plastic items.



**Product Features:**

- Made from stainless steel weighing 300g.
- Punches a guitar plectrum out of any sheet plastic.
- Makes traditional shape guitar plectrums.
- Selling price: £8.50.

**Dimensions:**

- Plectrum punch measures approximately 160 mm (L) x 88 mm (H) x 34 mm (W).
- Punched plectrums will measure approximately 30 mm (H) x 25 mm (W).

(a) Before designing the mechanical punch, a design specification was written. Study the **three** specification points below and explain how these have been met by the product.

(i) The mechanical punch must promote sustainability.

Explanation: ..... [2]

.....

(ii) The mechanical punch must be robust, durable and portable.

Explanation: ..... [2]

.....

(iii) The mechanical punch must be an affordable way of making lots of identical guitar plectrums.

Explanation: ..... [2]

.....

(b) Describe **one** safety issue that the designer would have considered when designing the mechanical punch. [2]

.....

.....

- (c) A manufacturer produces 500 mechanical punches. **Circle** the correct scale of production for making this number of products. [1]

**One-off Production      Batch Production      Continuous Flow Production**

- (d) When launching the mechanical punch as a new product, the manufacturer included the 10 plectrum holder shown below as part of the purchase. Explain why the manufacturer might have done this. [2]



Explanation: .....

.....

.....

- (e) The bar chart below shows the monthly sales totals for 2014.

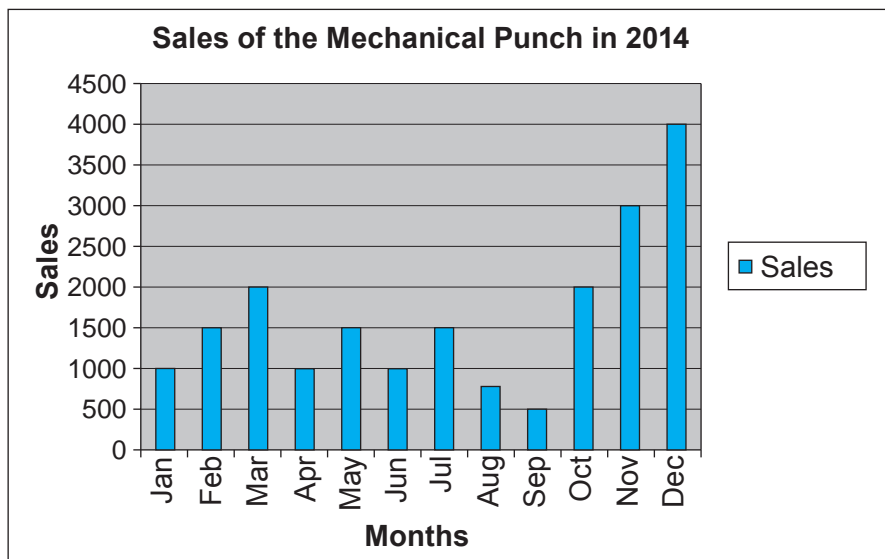

- (i) Give **one** reason for the sales being highest in December. [1]

.....

- (ii) **Circle** the correct number below to show the average sales for October, November and December. [1]

2500                      4500                      3500                      3000

- (iii) The mechanical punch is sold for £8.50. If 15% of this is profit, calculate how much profit is made if 750 mechanical punches are sold. (Show all your workings.) [2]

.....

.....

2. This question is about the general issues of Design and Technology. It is worth a total of 10 marks.

(a) Complete the diagram of the 6Rs below by adding the missing Rs. 3 × [1]  
(Three have been completed.)

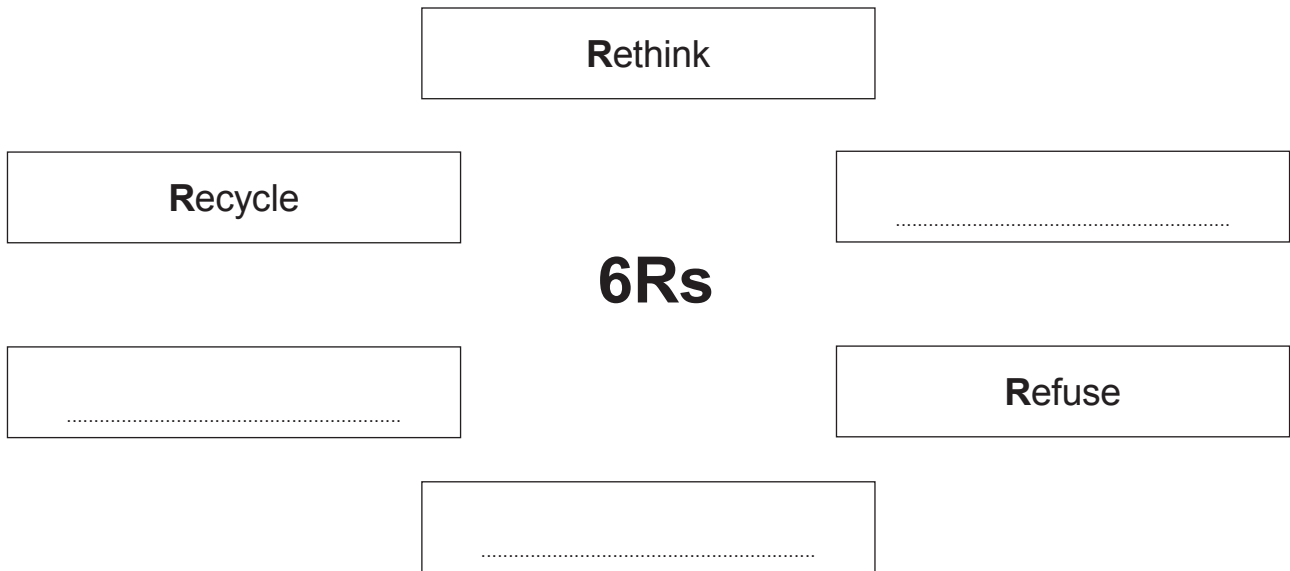

(b) Study the symbol shown below that appears on batteries and their packaging.



(i) State the meaning of this symbol. [1]

.....

(ii) Explain the importance of the symbol's meaning in relation to the environment. [2]

.....

.....

.....

- (c) Recent legislation has meant that traditional incandescent light bulbs have been phased out and replaced by newer LED based bulbs.



Incandescent light bulbs



LED based bulbs

- (i) Explain why these legislative actions have been taken. [2]

.....

.....

.....

- (ii) Identify **one** winner and **one** loser affected by these legislative changes. [2]

.....

.....

.....

.....

4121  
010005

Examiner only

3. This question is about the Designers that you have studied. It is worth a total of 10 marks.

During your course you have studied the work of Shigeru Miyamoto and Jonathan Ive.

(a) Write the name of the correct designer associated with **each** of the images below.

2 × [1]



Designer: .....

Designer: .....

(b) For either Jonathan Ive or Shigeru Miyamoto, write a short essay in the space below describing their work and outlining how it has influenced consumers in the market. [8]

*Marks will be awarded for the content of the answer and the quality of written communication.*

.....

.....

.....

.....

.....

.....

.....

.....

.....

.....

.....

.....

.....

.....

.....

.....

.....

.....

.....

.....

.....

.....

.....

4. This question is about the Design Process and how it is used. It is worth a total of 25 marks.

(a) Draw a line to connect **each** design term to the correct meaning. 3 × [1]

***Design Term***

***Meaning***

Development of ideas

Consider the making stages and time required to make the product.

Planning

Changes that are needed to improve a product.

Modifications

Improving and refining possible solutions.

(b) Describe why it is important to undertake market research before designing a new product. [2]

.....  
.....

(c) Explain why manufacturers often produce updated versions of their existing products. [2]

.....  
.....  
.....  
.....

4121  
010007

- (d) A fast food restaurant requires you to design an illuminating table centre to store salt, vinegar and pepper dispensers.

The dispensers are **identical** and measure 40 mm x 40 mm and are 70 mm tall.



Dispenser

Examiner  
only

Specification

**The device must:**

- be battery powered and illuminate **three** ultra-bright white LEDs when **one or more** of the dispensers are removed from the table centre;
- keep the LEDs 'on' until all **three** dispensers are replaced;
- be made from suitable materials and easy to wipe clean;
- include an on/off switch and method of replacing the batteries.

**Marks will be awarded for:**

- (i) fully labelled details of the overall look of the device; [4]
- (ii) a block diagram of the electronic system used; [3]
- (iii) details of the electronic circuit used in the device; [5]
- (iv) details of how the device is triggered; [2]
- (v) sizes, materials and quality of communication. [4]

Draw fully labelled details of the overall look of the device in the box below.



Examiner  
only

Draw a block diagram of the electronic system in the box below.

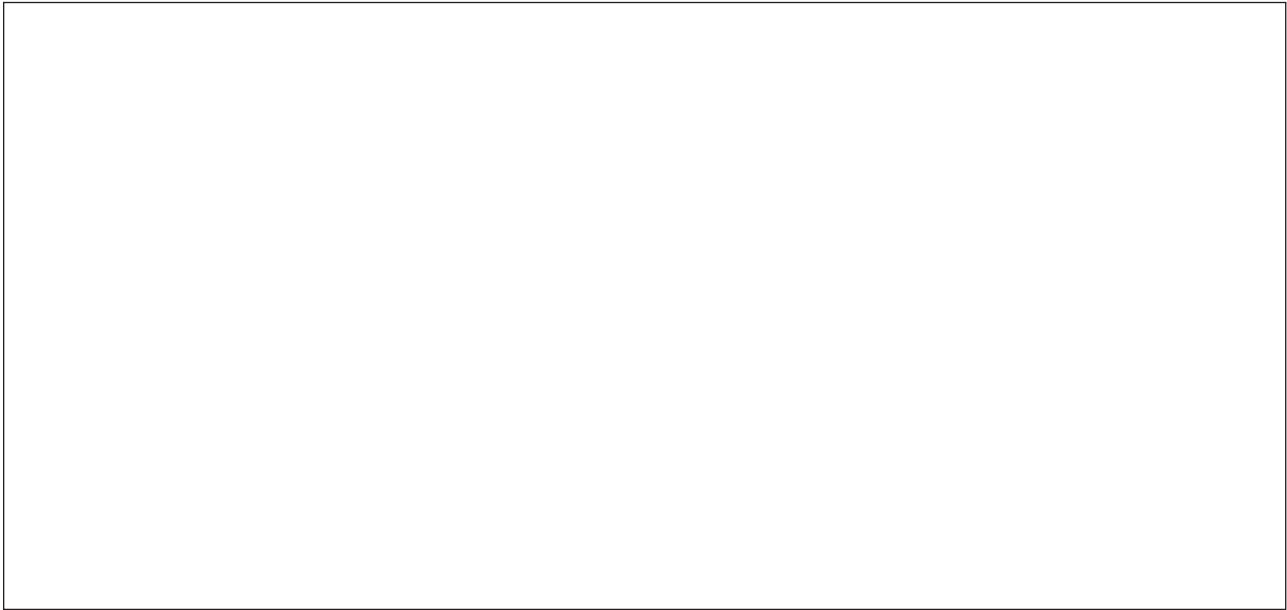

Draw details of the electronic circuit used in the box below, including details of triggering the device.

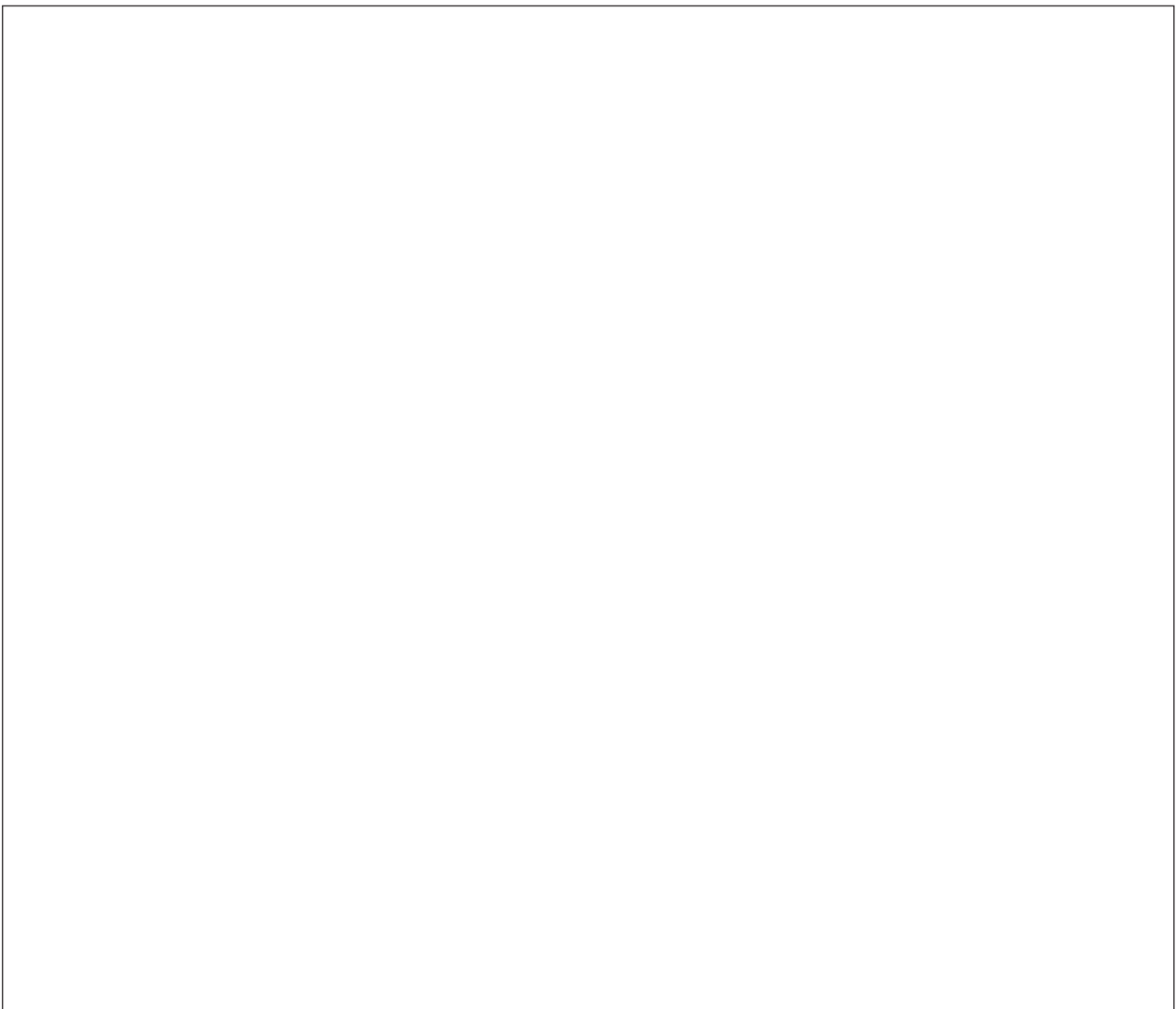

4121  
010009

**Section B**

Marked out of 60 60 minutes

5. This question is about Commercial Manufacturing Processes. It is worth a total of 10 marks.

(a) (i) Using the terms below, select the correct term for **each** of the images shown.

**Laser Cutting Drawing      2D Printed Circuit Board (PCB) layout      3D Schematic Drawing**

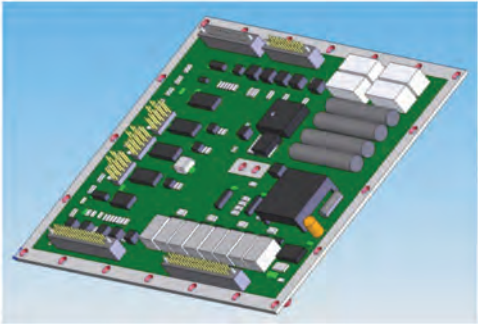
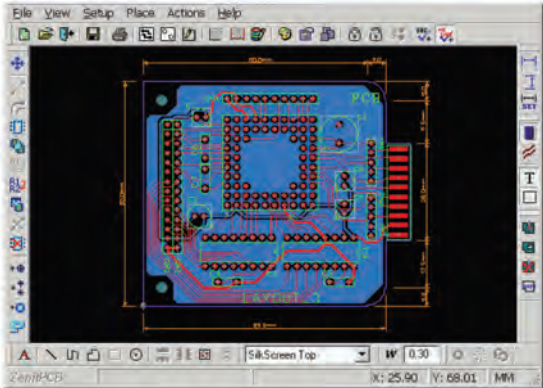
	
<p>..... [1]</p>	<p>..... [1]</p>

(ii) In industry, electronic systems are often designed using computers. **Circle** the correct term below that represents this process. [1]

**CAM                  CAD                  CNC**

(iii) Computers can often speed up the designing process. Describe **two** other advantages to the manufacturer when using computers to design electronic systems.

Advantage 1: .....

..... [2]

Advantage 2: .....

..... [2]

Examiner  
only

(b) Global manufacturing is when parts of products are designed and made in different countries. Describe the role computers play in global manufacturing. [3]

.....

.....

.....

.....

.....

.....

4121  
010011

6. This question is about Materials and Components. It is worth a total of 15 marks.

(a) Study the mechanism shown below.



(i) **Circle** the correct name for this mechanism. [1]

**Pawl and ratchet      Worm drive and spur      Bevel gear**

(ii) Complete the statement below by adding the correct type of motion. [2]

This mechanism converts ..... motion through  
..... degrees.

(b) The pulley system shown below is used to power a toy helicopter.

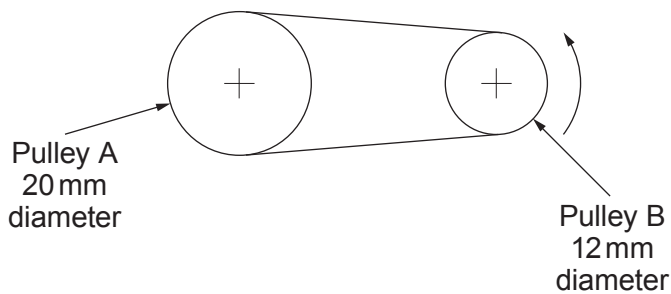

(i) Complete the table below by placing a **tick** (✓) to show whether each statement is true or false. [3]

<b>Statement</b>	<b>True</b>	<b>False</b>
Pulley B rotates faster than Pulley A.		
The pulleys must be connected with a belt in tension.		
The helicopter uses a compound pulley system.		



- (ii) Calculate the rotational velocity (RV) of Pulley B when the motor connected to Pulley A rotates at 30rpm. [2]  
 (Show all your workings.)

.....

.....

.....

- (c) Complete the table by sketching the electronic circuit symbol for **each** electronic component. 3 × [1]

- (d) The diagram below shows a gymnast standing on a balance beam in equilibrium.

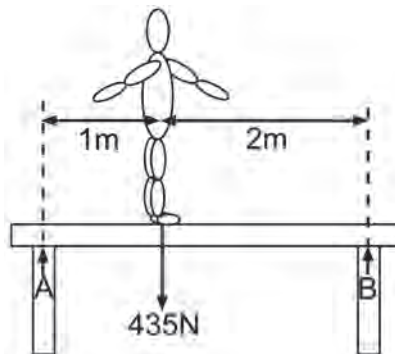

- Calculate the reaction force at Pillar A. [4]  
 (Show all your workings.)

.....



.....

.....

7. This question is about Tools, Equipment and Making. It is worth a total of 20 marks.

(a) Using the terms below, complete the table by writing the correct term for the electronic modelling methods. 3 × [1]

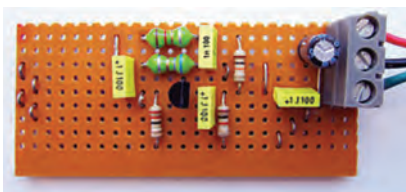
Stripboard      Surface Mount Technology (SMT)      Loctronics Kit      Breadboard / Protobloc

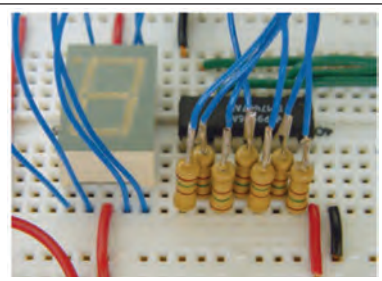
		
.....	.....	.....

(b) Correctly name the **three** tools below found in systems and control workshops. 3 × [1]



(i) .....



(ii) .....



(iii) .....

(c) A soldering iron is set up in preparation to construct an electronic control system. Complete the statements below by **circling** the correct options.



(i) Once set up a soldering iron **can** / **cannot** be removed from the holder. [1]

(ii) Soldering irons can heat up to **100 degrees C** / **400 degrees C**. [1]

(iii) Soft solder melts at **180 degrees C** / **300 degrees C**. [1]

(d) A student has designed and made a mobile phone stand as shown below.



(i) Name a suitable thermoplastic material to make the hollow base of the device. [1]

.....

(ii) Name the process used to make the hollow base. [1]

.....

(iii) The transparent acrylic mobile phone holder has been shaped using line bending. Study the picture below and state the function of the parts labelled. 3 × [1]

.....  
 .....  
 .....  
 .....  
 .....  
 .....



- (iv) Using labelled sketches, describe how the student used tools and equipment, including the line bender, to make the transparent acrylic mobile phone holder. [4]

Examiner  
only

- (e) In the space below, produce a labelled sketch showing a temporary method of fixing the hollow base to the transparent holder. [2]



**BLANK PAGE**

8. This question is about ICT, CAD, CAM, Systems and Processes. It is worth a total of 15 marks.

(a) The greenhouse shown below is fitted with an automatic environmental control system that ensures:

- the two windows are opened if the temperature inside is above 40°C;
- the windows close again if the temperature drops below 34°C;
- the plants will be watered if the temperature is above 40°C and the soil is dry;
- the sprinklers do not activate if the soil is moist.

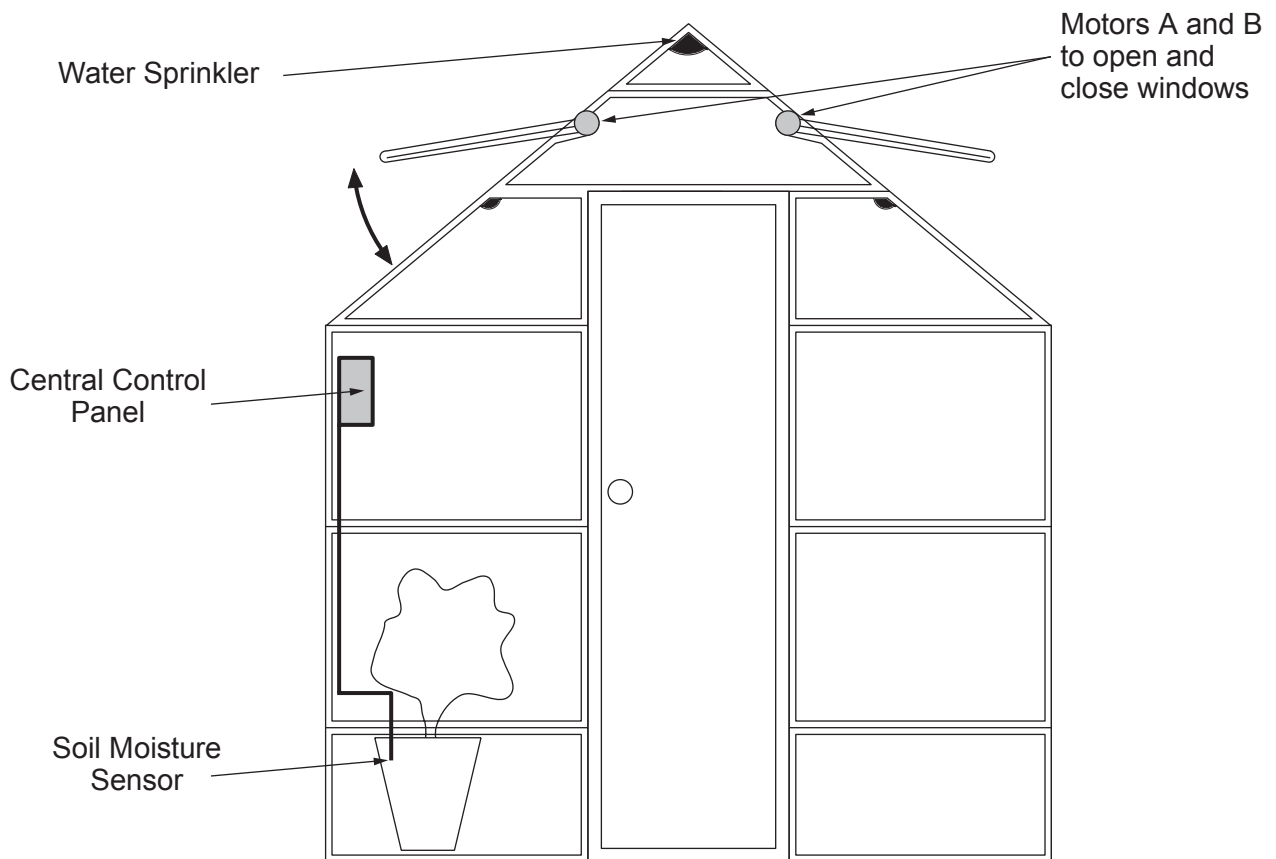

Complete the table by placing a **tick** (✓) to show whether the statement is true or false.

[1]

	True	False
The soil moisture sensor is a digital device.		

(b) The flowchart below shows how the greenhouse system is controlled.

(i) Complete the flowchart by placing the statements in the correct positions and adding any missing feedback loops. [7]

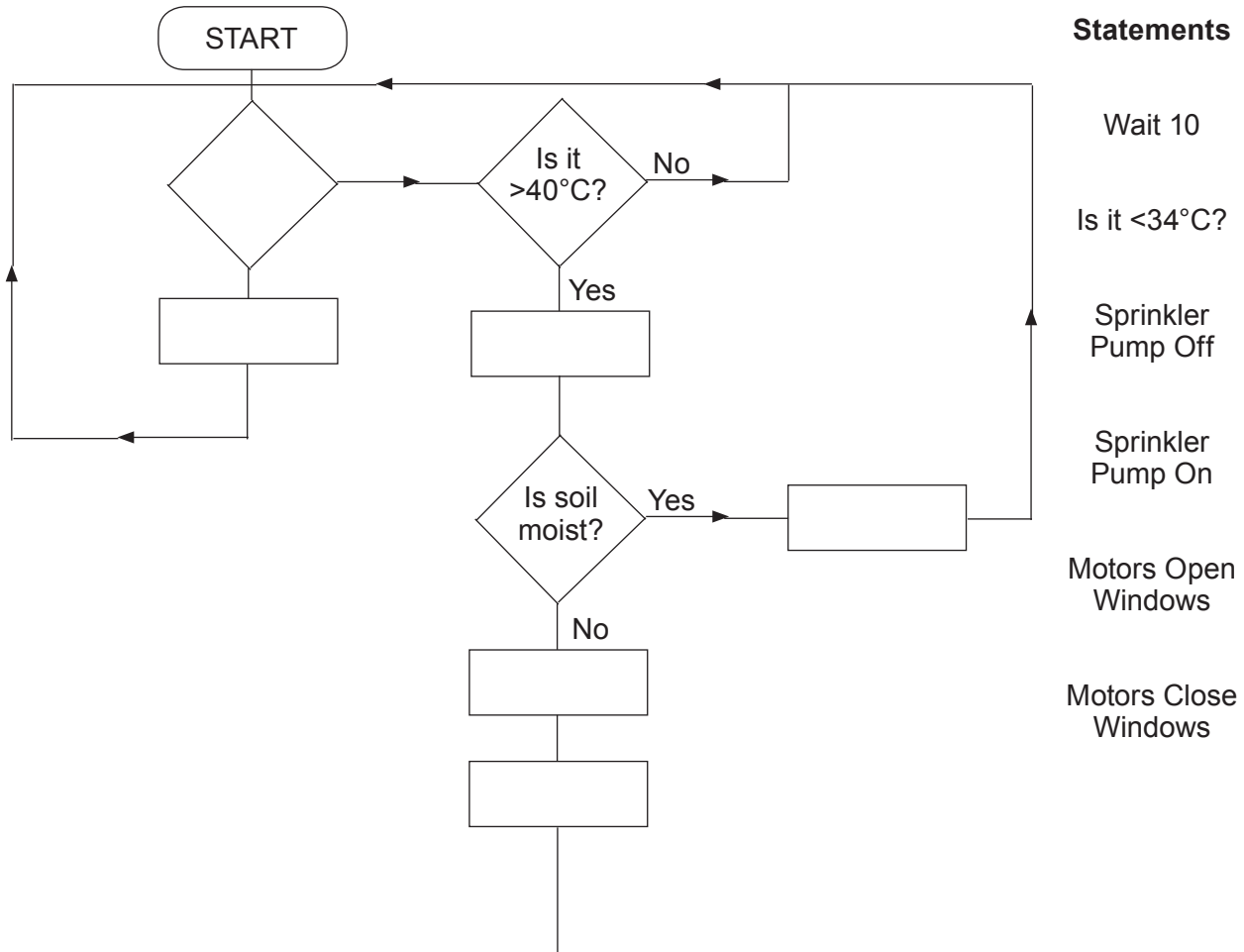



(ii) Explain **one** problem that might arise if this control system is used. [2]

.....

.....

.....

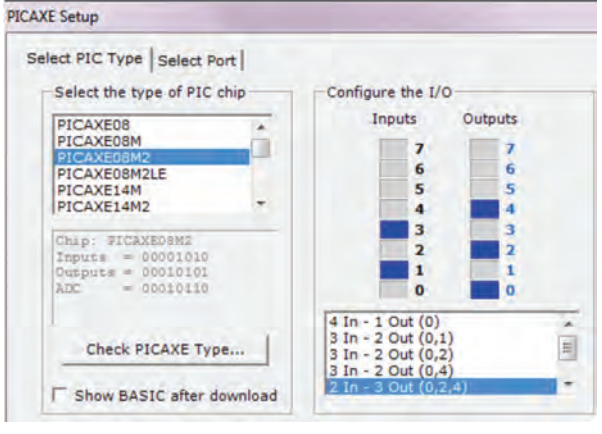
- (c) The greenhouse control system is to be controlled by an 8 Pin PIC chip because there are five inputs/outputs in total. Study the information below, showing details of how a PIC has been set up to control inputs and outputs.

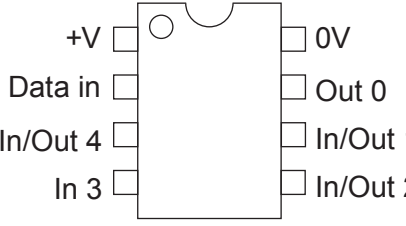
		
<p>8 Pin PIC chip configuration</p>	<p>8 Pin PIC chip</p>	<p>Pin Out Data for 8 Pin PIC chip</p>

Complete the diagram below to show how you would connect the **five** components below in the greenhouse control system to an 8 Pin PIC chip configuration. [5]

- Motor A      Motor B      Soil Sensor      Temperature Sensor      Water Pump**

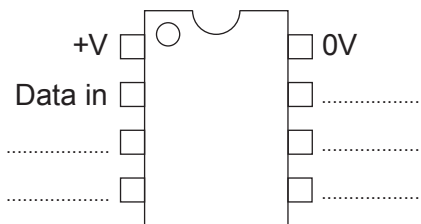

**END OF PAPER**



**BLANK PAGE**

**BLANK PAGE**